



a constant flow of solutions

Quick Couplings Catalog

stucchigroup.com

PRODUCTS CATALOG

a constant flow of solutions





Since 1960, Stucchi is one of the leading manufacturers of quick disconnect couplings for all varieties of sizes and port configurations, ranging from 1/8" to 2" in dimensions to accommodate a wide range of application requirements.

Pressure capabilities extend to 700 bar working pressure; port configurations include BSP, NPT, SAE and metric standard in stock; materials range from brass to 316 stainless steel; and there is also an assortment of seal options.



Its solutions-based approach meets the demanding requirements for applications across multiple markets.

Product quality assurance is documented throughout the company's supply chain, beginning with raw materials certifications, ongoing improvements in production materials, automation of production, fatigue testing, pressure-testing parts prior to shipping, and an ISO quality-management system.



NEW



Stucchi Interchange

Select the Brand, the Series, the Part number and Stucchi Interchange will give you the equivalent Stucchi product.

Fill in the form on interchange.stucchi.it and discover the power of this tool.

Technical question? We are here to help you!

Every application is different and it may be challenging to choose the solution that will bring the most value and benefit to your equipment. That's why STUCCHI has a team of product engineers ready to help you to facilitate your work in every step of the process. **From the choice of the most suitable product to the pressure drop calculation or material compatibility check, they are here to assist you in all your design challenges.**

For more information please contact Stucchi Technical Support.

Custom solutions? Ask Stucchi!

Since 1960 Stucchi has proposed customized and innovative solutions to the market. A continuous search for solutions that have generated a strong competence about the product and its many applications.

For more information please contact Stucchi Technical Support.

WARNING

A defect, a wrong choice or an improper use of products, can cause injury to persons, animals and objects. Connect under pressure products are suitable to be connected under residual (static) pressure. Never connect or disconnect with dynamic pressure (e.g. pump on).

Make sure that the medium used is compatible with seal and material as indicated for each series. In case of doubt please contact Stucchi Technical Support.

The interchangeability is mentioned under the assumption that the manufacturer of the considered products has not changed any dimension.

It is MANDATORY to read and closely follow the instructions. Last updated version always apply at time of installation, see latest written Instructions on Stucchi website (stucchigroup.com) before selecting or using Stucchi products.



INTRODUCTION

009	Certifications	
010	Applications	
011	Products directory	Please use Products directory for a better overview of each series specificities

SERIES

015	FLAT FACE		
	FIRG	Standard	17
	A	Modular	25
	APM	Male side connectable with residual pressure	39
	A-HD	Female side connectable with residual pressure	45
	AX	Modular, highly corrosive environments	51
	FIRG-Q	Medium corrosive environments	57
	FL	Standard, highly corrosive environments	65
071	FLAT FACE SCREW		
	VEP-P	Flat face, screw, connectable with residual pressure	73
	VEP-HD	Flat face, screw, connectable with residual pressure in heavy duty applications	81
	VP-P	Flat face, screw, connectable with residual pressure, safety sleeve	89
097	CASTING		
	SATURN	Knob to release residual pressure	99
	SATURN HF		105
111	POPPET SCREW		
	VD	Screw, poppet valving style, ISO14541	113
	VLS	Screw, poppet valving style, interchangeable with similar couplings	123
	VOF	Interchangeable with similar couplings, high strength carbon steel, Oil&Gas	129
	VOFX	Interchangeable with similar couplings (Oil&Gas), Stainless steel	135
	VR	Screw, special valve mechanism, interchangeable with similar couplings	141
147	POPPET		
	BIR	Poppet valving style	149
	I/IP	Push-pull function	157
	IR	Ball valving style	165
	IR-V	Interchangeable with similar couplings	171
	IRB	High strength carbon steel	177
	IRBO	Brass	183
	IRBX	Stainless steel	189
	IRC	Interchangeable with similar couplings (Nordic), high strength carbon steel	195
	IRCX	Interchangeable with similar couplings (Nordic), Stainless steel	201
	IFR	ISO 5676 "NF U 16-006"	207
213	HIGH PRESSURE		
	A-HP	Flat face	215
	IV-HP	Market standard	219
225	CHECK VALVE		
	VUZ - VU	One-way valve	227
233	VEHICLE A/C		
	ACR-ACB	Vehicles refrigeration, SAE J639	235
240	MULTICOUPLINGS		

TECHNICAL INFO

242	Instructions and warnings
244	Conversion table
246	Glossary

FLAT FACE

FLAT FACE SCREW

CASTING

POPPET SCREW

POPPET

HIGH PRESSURE

CHECK VALVE

VEHICLE A/C

MULTICOUPLINGS





ISO 9001, ISO 14001, ISO 45001

After certification of occupational health and safety management system (**ISO 45001**), Stucchi reached another major objective of the company policies through a careful performance of the service for the full compliance with national and international environmental management systems, certifying its model of business organization according to the **UNI EN ISO 14001:2004**.



ISO 14001



ISO 9001



ISO 45001

Certifications available on request

Applications



The strength that distinguishes Stucchi in the market is a “constant flow of solutions” in the development, manufacturing and distribution of products for fluid connections.

The vision that drives us towards the future is to be recognized by our customers as the supplier of choice for fluid power products and solutions that are easy to use, safe, durable, environmentally friendly and that help in saving energy. Following these principles Stucchi offers solutions that cover a wide range of applications constantly ensuring the quality of products.



Earth Moving

Stucchi couplings are suitable for machines and systems related with controlling mobile equipment used in off-highway applications.



Oil & Gas

In exploration, extraction, field services (upstream), storage and conveyance (downstream) of crude oil and natural gas Stucchi products are the best solutions.



Vehicles

Vehicle manufacturers appreciate Stucchi couplings for their high performances in hydraulic applications systems to connect different tools or trailers.



Agriculture

From conventional ‘popet design’ profile to flat face and multicouplings, Stucchi products are present on agricultural machines and attachments.



Industry

Stucchi couplings are present on machineries and systems used for industrial manufacturing.



Hydraulic Tools

Machineries and systems related to various hydraulic equipment (machine and automation tools, powered hand tools) require high performance couplings and Stucchi can provide them.



High Pressure

Stucchi couplings are present on systems associated with high pressure applications; not only on jacks, ram or clamping devices but also on rescue equipment.



Refrigeration

Stucchi quick couplings are equipped on systems associated with vehicles refrigeration (A/C recharge) and isothermal bodies through low temperature eutectic plates.



Cooling

Machineries for cooling of systems with water or water glycol can be equipped with Stucchi quick couplings.



Chemical & Food Industry

Stucchi couplings are used in chemical applications where flow performances associated with non-spill design allows to increase system specifications and to protect the environment.

FLAT FACE



FIRG

Valving style: Flat face
Interchange: ISO 16028
Sealing description: Nitrile NBR
Available sizes: From 1/4" to 2"
Operating pressure: Up to 330 bar
Flow rate: Up to 1000 l/min
Material / Treatment:
Carbon steel / Cr3

p. 17



A

Valving style: Flat face
Interchange: ISO 16028
Sealing description: Nitrile NBR
Available sizes: From 1/8" to 1-1/2"
Operating pressure: Up to 420 bar
Flow rate: Up to 750 l/min
Material / Treatment:
Carbon steel / Cr3

p. 25



APM

Valving style: Flat face
Interchange: ISO 16028
Sealing description: Nitrile NBR
Available sizes: From 3/8" to 1-1/2"
Operating pressure: Up to 350 bar
Flow rate: Up to 750 l/min
Material / Treatment:
Carbon steel / Cr3
Connection under pressure:
One side only

p. 39



A-HD

Valving style: Flat face
Interchange: ISO 16028
Sealing description: Nitrile NBR
Available sizes: From 3/8" to 1/2"
Operating pressure: Up to 350 bar
Flow rate: Up to 90 l/min
Material / Treatment:
Carbon steel / Cr3
Connection under pressure:
One side only

p. 45



AX

Valving style: Flat face
Interchange: ISO 16028
Sealing description: FKM (Viton®)
Available sizes: From 3/8" to 1"
Operating pressure: Up to 350 bar
Flow rate: Up to 378 l/min
Material / Treatment:
Stainless steel (AISI 316L)

p. 51



FIRG-Q

Valving style: Flat face
Interchange: ISO 16028
Sealing description:
Nitrile NBR-FKM(Viton®)-EPDM-Kalrez®
Available sizes: From 1/4" to 2"
Operating pressure: Up to 300 bar
Flow rate: Up to 1000 l/min
Material / Treatment: Carbon steel
+Stainless steel (AISI 316L) / QPQ

p. 57



FL

Valving style: Flat face
Interchange: ISO 16028
Sealing description: FKM (Viton®)
Available sizes: From 1/8" to 2"
Operating pressure: Up to 350 bar
Flow rate: Up to 1000 l/min
Material / Treatment:
Stainless steel (AISI 316L)

p. 65

FLAT FACE SCREW



VEP-P

Valving style: Flat face
Interchange: Stucchi profile
Sealing description: Nitrile NBR
Available sizes: From 1/4" to 2"
Operating pressure: Up to 600 bar
Flow rate: Up to 1000 l/min
Material / Treatment:
Carbon steel / Cr3+QPQ
Connection under pressure: Allowed

p. 73



VEP-HD

Valving style: Flat face
Interchange: Stucchi profile
Sealing description: Nitrile NBR
Available sizes: From 5/8" to 1-1/2"
Operating pressure: Up to 550 bar
Flow rate: Up to 750 l/min
Material / Treatment:
Carbon steel / QPQ
Connection under pressure: Allowed

p. 81



VP-P

Valving style: Flat face
Interchange: Stucchi profile
Sealing description: Nitrile NBR
Available sizes: From 1/4" to 1-1/2"
Operating pressure: Up to 600 bar
Flow rate: Up to 750 l/min
Material / Treatment:
Carbon steel / Cr3+QPQ
Connection under pressure: Allowed

p. 89

CASTING



SATURN

Valving style: Flat face
Interchange: ISO 16028
Sealing description: Nitrile NBR
Available sizes: From 1/2" to 3/4"
Operating pressure: Up to 350 bar
Flow rate: Up to 200 l/min
Material / Treatment:
Carbon steel / Cr3
Connection under pressure:
One side only

p. 99



SATURN HF

Valving style: Flat face
Interchange: ISO 16028
Sealing description: Nitrile NBR
Available sizes: From 1/2" to 3/4"
Operating pressure: Up to 350 bar
Flow rate: Up to 200 l/min
Material / Treatment:
Carbon steel / Cr3
Connection under pressure:
One side only

p. 105

POPPET SCREW



VD

p. 113

Valving style: Poppet
Interchange: ISO 14541
Sealing description: Nitrile NBR
Available sizes: From 1/4" to 1-1/4"
Operating pressure: Up to 450 bar
Flow rate: Up to 378 l/min
Material / Treatment:
Carbon steel / Cr3
Connection under pressure:
One side only



VLS

p. 123

Valving style: Poppet
Interchange: With similar couplings
Sealing description: Nitrile NBR
Available sizes: From 1/2" to 1"
Operating pressure: Up to 465 bar
Flow rate: Up to 200 l/min
Material / Treatment:
Carbon steel / Cr3
Connection under pressure:
One side only



VOF

p. 129

Valving style: Poppet
Interchange: With similar couplings
Sealing description: Nitrile NBR
Available sizes: From 3/4" to 2"
Operating pressure: Up to 345 bar
Flow rate: Up to 1100 l/min
Material / Treatment:
Carbon steel / Cr3
Connection under pressure:
One side only



VOFX

p. 135

Valving style: Poppet
Interchange: With similar couplings
Sealing description: Nitrile NBR
Available sizes: From 3/4" to 2"
Operating pressure: Up to 207 bar
Flow rate: Up to 1100 l/min
Material / Treatment:
Stainless steel (AISI 316L)
Connection under pressure:
One side only

POPPET



VR

p. 141

Valving style: Flat face non-spill
Interchange: With Rohrleitung couplings
Sealing description: Nitrile NBR
Available sizes: From 3/8" to 1-1/4"
Operating pressure: Up to 420 bar
Flow rate: Up to 576 l/min
Material / Treatment:
Carbon steel / Cr3
Connection under pressure:
One side only



BIR

p. 149

Valving style: Poppet
Interchange: ISO 7241 'A'
Sealing description: Nitrile NBR
Available sizes: From 1/4" to 2"
Operating pressure: Up to 350 bar
Flow rate: Up to 1000 l/min
Material / Treatment:
Carbon steel / Cr3
Connection under pressure:
Allowed (only PC version)



I/IP

p. 157

Valving style: Poppet
Interchange: ISO 7241 'A'
Sealing description: Nitrile NBR
Available sizes: From 1/4" to 2"
Operating pressure: Up to 350 bar
Flow rate: Up to 200 l/min
Material / Treatment:
Carbon steel / Cr3



IR

p. 165

Valving style: Ball
Interchange: With similar couplings
Sealing description: Nitrile NBR
Available sizes: From 1/4" to 1"
Operating pressure: Up to 300 bar
Flow rate: Up to 150 l/min
Material / Treatment:
Carbon steel / Cr3



IR-V

p. 171

Valving style: Poppet
Interchange:
With similar couplings
Sealing description: Nitrile NBR
Available sizes: From 1/4" to 1"
Operating pressure: Up to 300 bar
Flow rate: Up to 200 l/min
Material / Treatment:
Carbon steel / Cr3



IRB

p. 177

Valving style: Poppet
Interchange: ISO 7241 'B'
Sealing description: Nitrile NBR
Available sizes: From 1/8" to 1"
Operating pressure: Up to 350 bar
Flow rate: Up to 200 l/min
Material / Treatment:
Carbon steel / Cr3



IRBO

p. 183

Valving style: Poppet
Interchange: ISO 7241 'B'
Sealing description: FKM (Viton®)
Available sizes: From 1/8" to 1"
Operating pressure: Up to 200 bar
Flow rate: Up to 200 l/min
Material / Treatment: Brass



IRBX

p. 189

Valving style: Poppet
Interchange: ISO 7241 'B'
Sealing description: FKM (Viton®)
Available sizes: From 1/8" to 1"
Operating pressure: Up to 250 bar
Flow rate: Up to 200 l/min
Material / Treatment:
Stainless steel & brass



IRC

p. 195

Valving style: Poppet
Interchange: Nordic interface
Sealing description: FKM (Viton®)
Available sizes: From 1/4" to 1"
Operating pressure: Up to 450 bar
Flow rate: Up to 378 l/min
Material / Treatment:
Carbon steel / Cr3
Connection under pressure:
Allowed (only PC version)



IRCX

p. 201

Valving style: Poppet
Interchange: Nordic interface
Sealing description: FKM (Viton®)
Available sizes: From 1/4" to 1"
Operating pressure: Up to 300 bar
Flow rate: Up to 378 l/min
Material / Treatment:
Stainless steel (AISI 316L)



IFR

p. 207

Valving style: Flat face non-spill
Interchange: ISO 5676
Sealing description: Nitrile NBR
Available sizes: 3/8"
Operating pressure: Up to 150 bar
Flow rate: Up to 46 l/min
Material / Treatment:
Carbon steel / Cr3

HIGH PRESSURE

A-HP

p. 215

Valving style: Flat Face
 Interchange: Stucchi profile
 Sealing description: Nitrile NBR
 Available sizes: From 1/8" to 3/8"
 Operating pressure: Up to 700 bar
 Flow rate: Up to 46 l/min
 Material / Treatment:
 Carbon steel / Cr3

IV-HP

p. 219

Valving style: Ball
 Interchange: With similar couplings (high pressure)
 Sealing description: Nitrile NBR
 Available sizes: From 1/4" to 3/8"
 Operating pressure: Up to 700 bar
 Flow rate: Up to 23 l/min
 Material / Treatment:
 Carbon steel / Cr3

CHECK VALVE

VUZ

p. 227

Available sizes: From 1/8" to 2"
 Operating pressure: Up to 400 bar
 Flow rate: Up to 1000 l/min
 Material / Treatment:
 Carbon steel / Cr3

VEHICLE A/C

ACR-ACB

p. 235

Valving style: Poppet
 Interchange: SAE J639
 Sealing description: HNBR
 Available sizes: 1/4"
 Operating pressure: Up to 41 bar
 Material / Treatment: Aluminium, Brass

MULTICOUPLINGS

Easy
CUP

DP

p. 241

Valving style: Flat face
 Interchange: Stucchi profile
 Sealing description: Nitrile NBR
 Available sizes: From 3/8" to 1"
 Flow rate: Up to 378 l/min
 Material: Carbon steel, Aluminium / Cr3
 Connection under pressure: Allowed

Easy
CUP

GR

p. 241

Valving style: Flat face
 Interchange: Stucchi profile
 Sealing description: Nitrile NBR
 Available sizes: From 3/8" to 1"
 Flow rate: Up to 378 l/min
 Material: Carbon steel, Brass / Cr3
 Connection under pressure: Allowed

GRE

p. 241

Valving style: Flat face
 Interchange: Stucchi profile
 Sealing description: Nitrile NBR
 Available sizes: From 3/8" to 1/2"
 Operating pressure: Up to 10 bar
 Flow rate: Up to 90 l/min
 Material: Aluminium

Easy
CUP

Easy Connection Under Pressure is the Stucchi solution for manual connection with residual pressure in the circuit. The male couplings have a triple valve system that allows the easy connection of couplings with internal residual pressure, in safe condition and without fluid loss.

BOP

Blow Out Prevention
 Specific dimensions are fire tested and Lloyd certified in accordance with API 16D and the EUB Directive #36. For complete technical information please contact Stucchi technical support.





FIRG

p. 17

Valving style: Flat face
 Interchange: ISO 16028
 Sealing description: Nitrile NBR
 Available sizes: From 1/4" to 2"
 Operating pressure: Up to 330 bar
 Flow rate: Up to 1000 l/min
 Material / Treatment:
 Carbon steel / Cr3



A

p. 25

Valving style: Flat face
 Interchange: ISO 16028
 Sealing description: Nitrile NBR
 Available sizes: From 1/8" to 1-1/2"
 Operating pressure: Up to 420 bar
 Flow rate: Up to 750 l/min
 Material / Treatment:
 Carbon steel / Cr3



APM

p. 39

Valving style: Flat face
 Interchange: ISO 16028
 Sealing description: Nitrile NBR
 Available sizes: From 3/8" to 1-1/2"
 Operating pressure: Up to 350 bar
 Flow rate: Up to 750 l/min
 Material / Treatment:
 Carbon steel / Cr3
 Connection under pressure:
 One side only



A-HD

p. 45

Valving style: Flat face
 Interchange: ISO 16028
 Sealing description: Nitrile NBR
 Available sizes: From 3/8" to 1/2"
 Operating pressure: Up to 350 bar
 Flow rate: Up to 90 l/min
 Material / Treatment:
 Carbon steel / Cr3
 Connection under pressure:
 One side only



AX

p. 51

Valving style: Flat face
 Interchange: ISO 16028
 Sealing description: FKM (Viton®)
 Available sizes: From 3/8" to 1"
 Operating pressure: Up to 350 bar
 Flow rate: Up to 378 l/min
 Material / Treatment:
 Stainless steel (AISI 316L)



FIRG-Q

p. 57

Valving style: Flat face
 Interchange: ISO 16028
 Sealing description: Nitrile NBR-
 FKM(Viton®)-EPDM-Kalrez®
 Available sizes: From 1/4" to 2"
 Operating pressure: Up to 300 bar
 Flow rate: Up to 1000 l/min
 Material / Treatment:
 Carbon steel+Stainless steel
 (AISI 316L) / QPQ



FL

p. 65

Valving style: Flat face
 Interchange: ISO 16028
 Sealing description: FKM (Viton®)
 Available sizes: From 1/8" to 2"
 Operating pressure: Up to 350 bar
 Flow rate: Up to 1000 l/min
 Material / Treatment:
 Stainless steel (AISI 316L)



FIRG SERIES

INTERCHANGE > ISO 16028 - NFPA T3.20.15 - HTMA (size 3/8")



Stucchi®

FLAT FACE



TECHNICAL FEATURES AND OPTIONS

Interchange ISO 16028 NFPA T3.20.15 HTMA (size 3/8")	Sealing description Nitrile NBR	Connection system Push
Available sizes from 1/4" to 2"	Material/treatment Carbon steel /Cr3	Available threads BSP - NPT - BSPT - SAE
Operating pressure Up to 330 bar	Locking mechanism Locking ball + Safety Lock	Flow rate Up to 1000 l/min
Temperature (°C) -20° / +100°	Valving style Flat face	Connection under pressure Connection: not allowed Disconnection: not allowed

BENEFITS

- Flat face is easy to clean, reducing the inclusion of contamination inside the hydraulic circuit.
- Minimal fluid spillage during disconnection, reducing fluid spillage to the environment.
- Minimal air inclusion during connection, enhancing correct function of the circuit.
- Linear flow reduces internal turbulence and pressure drop maintaining circuit efficiency.
- Good resistance to pressure impulses when the couplings are connected.
- Compact slim design.
- Safe and simple to use.

HOW TO USE

- Before to connect, clean the mating surface of the couplings to avoid dirt inclusion in the circuit.
- To connect push the male half towards the female half or vice versa.
- After connection turn the external sleeve to engage safety lock function, to prevent accidental disconnection.
- To disconnect turn the external sleeve until the sleeve lock notch match the safety lock ball and push back the sleeve.

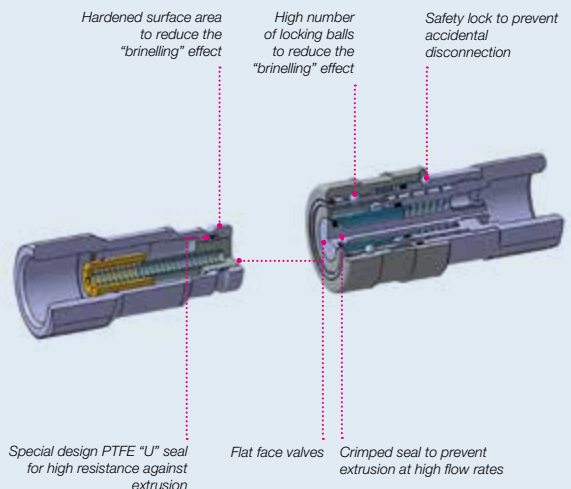
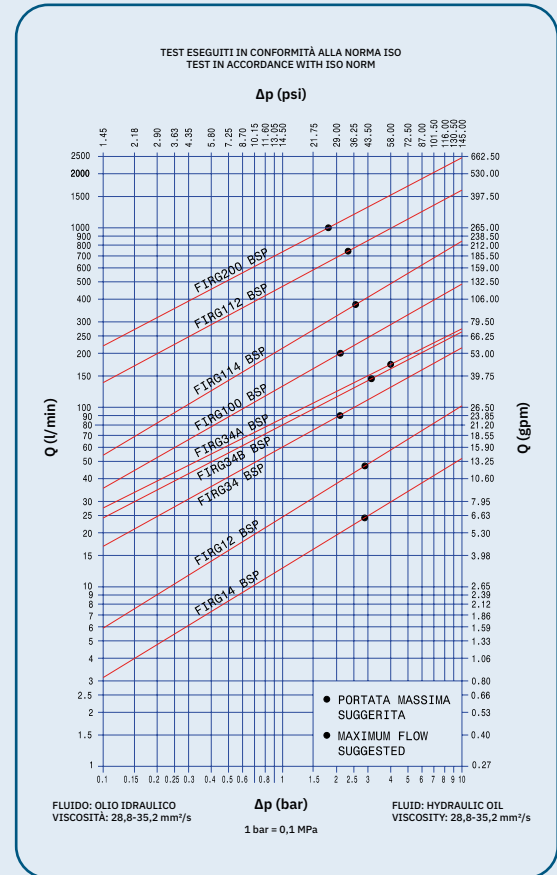

MAIN APPLICATIONS

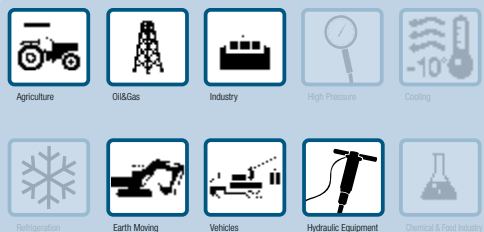

PERFORMANCES

Size		Series/Size	Max. flow suggested		Connect force		Disconnect force		Spillage*
Inch	mm (ISO)		l/min	gpm	N	lbf	N	lbf	ml
1/4	6,3	FIRG14	24	6,36	140	31,50	40	9,00	0,01
3/8	10,0	FIRG38-12	46	12,19	150	33,75	40	9,00	0,01
1/2	12,5	FIRG12A-34	90	23,85	160	36,00	60	13,50	0,02
5/8	16,0	FIRG34B	148	39,22	180	40,50	55	12,38	0,02
3/4	19,0	FIRG34A	170	45,05	270	60,75	90	20,25	0,03
3/4	19,0	FIRG100	200	53,00	240	54,00	65	14,63	0,03
1	25,0	FIRG114	378	100,17	310	69,75	100	22,50	0,03
1-1/2		FIRG112	750	198,75	390	87,75	90	20,25	0,05
2		FIRG200	1000	265,00	470	105,75	100	22,50	0,1

Size	Series/Size	Max. operating pressure						Burst pressure					
		Coupled		Male		Female		Coupled		Male		Female	
Inch		MPa	psi	MPa	psi	MPa	psi	MPa	psi	MPa	psi	MPa	psi
1/4	FIRG14	30	4350	42	6090	12	1740	120	17400	126	18270	48	6960
3/8	FIRG38-12	30	4350	30	4350	12	1740	120	17400	120	17400	48	6960
1/2	FIRG12A-34	25	3625	25	3625	10	1450	100	14500	100	14500	40	5800
5/8	FIRG34B	25	3625	22	3190	10	1450	100	14500	88	12760	40	5800
3/4	FIRG34A	33	4785	33	4785	33	4785	100	14500	100	14500	100	14500
3/4	FIRG100	25	3625	20	2900	10	1450	100	14500	80	11600	40	5800
1	FIRG114	25	3625	20	2900	10	1450	100	14500	80	11600	40	5800
1-1/2	FIRG112	20	2900	27	3915	8	1160	80	11600	80	11600	32	4640
2	FIRG200	20	2900	16	2320	8	1160	80	11600	64	9280	32	4640

* Spillage is an indicative value of the fluid loss during disconnection (according to ISO norm test method).

Different possible configurations:
BSPT thread available upon request.

Temperature range:

Standard seals NBR (Nitrile): from -20 °C to +100 °C (from -4 °F to +212 °F).
Upon request seals in VITON®: from -15°C to +180°C (from +5 °F to +356 °F).
Please read carefully Instructions and warnings for proper selection of the products.

Tests:

The couplings have been tested at max. operating pressure for 100.000 impulses according to ISO norm.

! WARNING

A defect, a wrong choice or an improper use of products, can cause injury to persons, animals and objects.
Never connect or disconnect with dynamic pressure (e.g. pump on).
Do not use the female coupling disconnected with high impulse pressure.
Do not couple-uncouple with flow and/or pressure in the circuit.
Do not couple-uncouple when the temperature inside of the circuit is higher than 80 °C (176 °F).
Check the maximum allowable working pressure of the port in use.
Make sure that the medium used is compatible with seal and material as indicated for each series.
In case of doubt please contact Stucchi Technical Support.
The interchangeability is mentioned under the assumption that the manufacturer of the considered products has not changed any dimension.
It is mandatory to carefully read and closely follow the instructions before selecting or using any Stucchi products.
Always refer to the version uploaded in the Instructions and warning section of stucchigroup.com website for the latest release.
For specific, product-related, instructions, please contact Stucchi technical service.

OVERALL DIMENSIONS

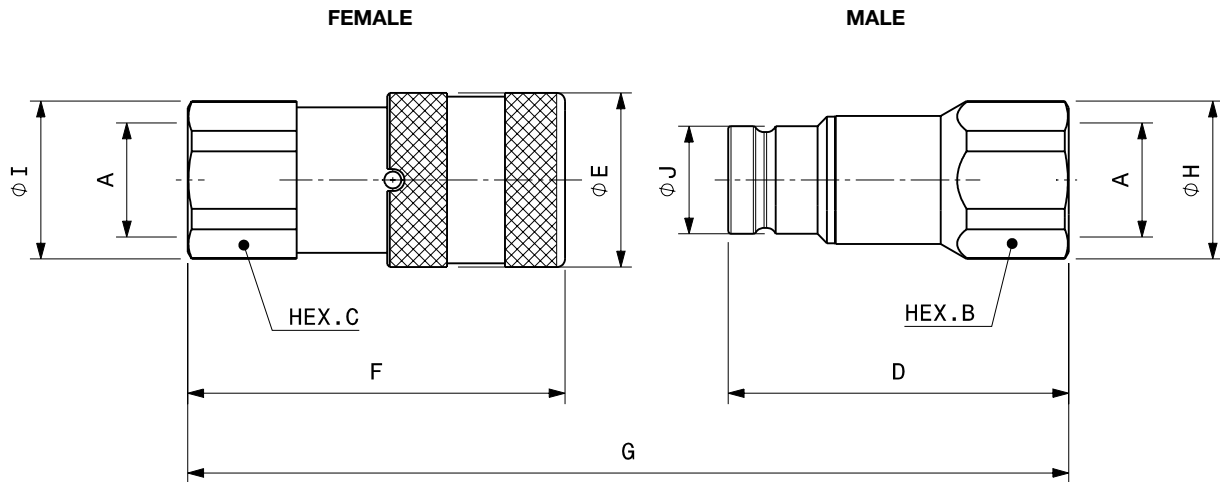

Port description: FEMALE THREAD BSPP (ISO1179-1)

BODY SIZE	Descriptive Code	Item Code	ISO DN	PORT (A)	Overall Length		Length		Hex		Diameter		Diameter		Weight						
					mm	inch	mm	inch	mm	inch	mm	inch	mm	inch	Kg	Lbs					
1/4"	F FIRG 14 BSP	Female 80080000	6,3	1/4"	G	85,2	3,35	F	48,1	1,89	C	22,0	0,87	I	23,8	0,94	E	28,0	1,10	0,14	0,31
	M FIRG 14 BSP	Male 80080001						D	47,9	1,89	B	22,0	0,87	H	23,8	0,94	J	16,1	0,63	0,09	0,19
3/8"	F FIRG 38 BSP	Female 80080004	10	3/8"	G	108,7	4,28	F	64,2	2,53	C	27,0	1,06	I	29,0	1,14	E	32,0	1,26	0,24	0,52
	M FIRG 38 BSP	Male 80080005						D	60,0	2,36	B	24,0	0,94	H	26,0	1,02	J	19,7	0,78	0,12	0,27
3/8"	F FIRG 12 BSP	Female 80080002	10	1/2"	G	116,2	4,57	F	69,2	2,72	C	27,0	1,06	I	29,0	1,14	E	32,0	1,26	0,24	0,52
	M FIRG 12 BSP	Male 80080003						D	62,5	2,46	B	27,0	1,06	H	29,0	1,14	J	19,7	0,78	0,13	0,28
1/2"	F FIRG 12A BSP	Female 80080006	12,5	1/2"	G	124,5	4,90	F	73,8	2,91	C	32,0	1,26	I	33,8	1,33	E	38,0	1,50	0,38	0,83
	M FIRG 12A BSP	Male 80080007						D	68,0	2,68	B	32,0	1,26	H	33,8	1,33	J	24,5	0,96	0,23	0,51
1/2"	F FIRG 34 BSP	Female 80080008	12,5	3/4"	G	134,0	5,28	F	80,8	3,18	C	36,0	1,42	I	38,5	1,52	E	38,0	1,50	0,41	0,91
	M FIRG 34 BSP	Male 80080009						D	70,5	2,78	B	36,0	1,42	H	38,5	1,52	J	24,5	0,96	0,23	0,50
5/8"	F FIRG 34B BSP	Female 80080010	16	3/4"	G	131,4	5,17	F	78,5	3,09	C	36,0	1,42	I	38,5	1,52	E	42,0	1,65	0,48	1,06
	M FIRG 34B BSP	Male 80080011						D	70,5	2,78	B	36,0	1,42	H	38,5	1,52	J	27,0	1,06	0,27	0,59
3/4"	F FIRG 34A BSP	Female 80080020	19	3/4"	G	149,0	5,87	F	88,7	3,49	C	41,0	1,61	I	44,8	1,76	E	48,0	1,89	0,75	1,65
	M FIRG 34A BSP	Male 80080021						D	82,3	3,24	B	41,0	1,61	H	44,8	1,76	J	30,0	1,18	0,45	0,98
3/4"	F FIRG 100 BSP	Female 80080012	19	1"	G	153,5	6,04	F	93,2	3,67	C	45,0	1,77	I	47,8	1,88	E	48,0	1,89	0,77	1,69
	M FIRG 100 BSP	Male 80080013						D	82,3	3,24	B	45,0	1,77	H	47,8	1,88	J	30,0	1,18	0,39	0,87
1"	F FIRG 114 BSP	Female 80080014	25	1-1/4"	G	172,8	6,80	F	106,0	4,17	C	55,0	2,17	I	59,8	2,35	E	55,0	2,17	1,22	2,68
	M FIRG 114 BSP	Male 80080015						D	89,8	3,54	B	55,0	2,17	H	59,8	2,35	J	36,0	1,42	0,64	1,41
1-1/2"	F FIRG 112 BSP	Female 80080016	-	1-1/2"	G	214,9	8,46	F	132,4	5,21	C	65,0	2,56	I	72,0	2,83	E	80,0	3,15	2,82	6,22
	M FIRG 112 BSP	Male 80080017						D	111,1	4,37	B	65,0	2,56	H	69,8	2,75	J	57,0	2,24	1,67	3,67
2"	F FIRG 200 BSP	Female 80080018	-	2"	G	241,5	9,51	F	156,6	6,17	C	80,0	3,15	I	88,5	3,48	E	100,0	3,94	5,10	11,24
	M FIRG 200 BSP	Male 80080019						D	123,8	4,87	B	75,0	2,95	H	83,5	3,29	J	73,0	2,87	2,26	4,98

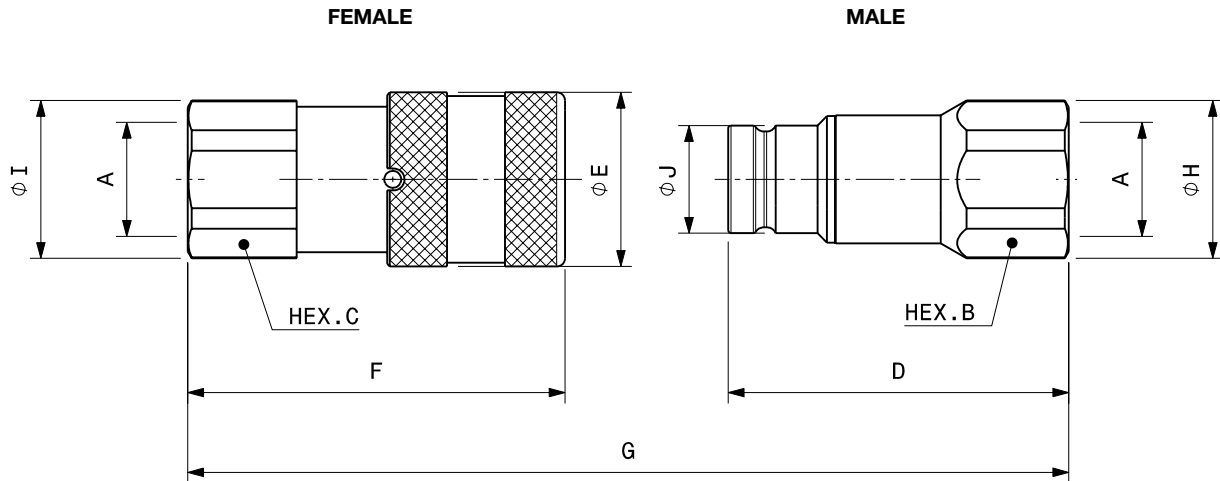

Port description: FEMALE THREAD NPT (ANSI B.1.20.1)

BODY SIZE	Descriptive Code	Item Code	ISO DN	PORT (A)	Overall Length	Length		Hex		Diameter		Diameter		Weight							
						mm	inch	mm	inch	mm	inch	mm	inch	mm	inch	Kg	Lbs				
1/4"	F FIRG 14 NPT	Female 800801000	6,3	1/4"	G	85,2	3,35	F	48,1	1,89	C	22,0	0,87	I	23,8	0,94	E	28,0	1,10	0,14	0,31
	M FIRG 14 NPT	Male 800801001						D	47,9	1,89	B	22,0	0,87	H	23,8	0,94	J	16,1	0,63	0,09	0,19
3/8"	F FIRG 38 NPT	Female 800801004	10	3/8"	G	108,7	4,28	F	64,2	2,53	C	27,0	1,06	I	29,0	1,14	E	32,0	1,26	0,24	0,52
	M FIRG 38 NPT	Male 800801005						D	60,0	2,36	B	24,0	0,94	H	26,0	1,02	J	19,7	0,78	0,12	0,27
3/8"	F FIRG 12 NPT	Female 800801002	10	1/2"	G	116,2	4,57	F	69,2	2,72	C	27,0	1,06	I	29,0	1,14	E	32,0	1,26	0,24	0,53
	M FIRG 12 NPT	Male 800801003						D	62,5	2,46	B	27,0	1,06	H	29,0	1,14	J	19,7	0,78	0,13	0,29
1/2"	F FIRG 12A NPT	Female 800801006	12,5	1/2"	G	124,5	4,90	F	73,8	2,91	C	32,0	1,26	I	33,8	1,33	E	38,0	1,50	0,38	0,83
	M FIRG 12A NPT	Male 800801007						D	68,0	2,68	B	32,0	1,26	H	33,8	1,33	J	24,5	0,96	0,24	0,52
1/2"	F FIRG 34 NPT	Female 800801008	12,5	3/4"	G	134,0	5,28	F	80,8	3,18	C	36,0	1,42	I	38,5	1,52	E	38,0	1,50	0,42	0,93
	M FIRG 34 NPT	Male 800801009						D	70,5	2,78	B	36,0	1,42	H	38,5	1,52	J	24,5	0,96	0,23	0,52
5/8"	F FIRG 34B NPT	Female 800801010	16	3/4"	G	131,4	5,17	F	78,5	3,09	C	36,0	1,42	I	38,5	1,52	E	42,0	1,65	0,49	1,08
	M FIRG 34B NPT	Male 800801011						D	70,5	2,78	B	36,0	1,42	H	38,5	1,52	J	27,0	1,06	0,27	0,60
3/4"	F FIRG 34A NPT	Female 800801020	19	3/4"	G	149,0	5,87	F	88,7	3,49	C	41,0	1,61	I	44,8	1,76	E	48,0	1,89	0,76	1,66
	M FIRG 34A NPT	Male 800801021						D	82,3	3,24	B	41,0	1,61	H	44,8	1,76	J	30,0	1,18	0,45	0,99
3/4"	F FIRG 100 NPT	Female 800801012	19	1"	G	153,5	6,04	F	93,2	3,67	C	45,0	1,77	I	47,8	1,88	E	48,0	1,89	0,78	1,72
	M FIRG 100 NPT	Male 800801013						D	82,3	3,24	B	45,0	1,77	H	47,8	1,88	J	30,0	1,18	0,41	0,89
1"	F FIRG 114 NPT	Female 800801014	25	1 1/4"	G	172,8	6,80	F	106,0	4,17	C	55,0	2,17	I	59,8	2,35	E	55,0	2,17	1,22	2,68
	M FIRG 114 NPT	Male 800801015						D	89,8	3,54	B	55,0	2,17	H	59,8	2,35	J	36,0	1,42	0,66	1,46
1-1/2"	F FIRG 112 NPT	Female 800801016	-	1 1/2"	G	214,9	8,46	F	132,4	5,21	C	65,0	2,56	I	72,0	2,83	E	80,0	3,15	2,85	6,28
	M FIRG 112 NPT	Male 800801017						D	111,1	4,37	B	65,0	2,56	H	69,8	2,75	J	57,0	2,24	1,67	3,68
2"	F FIRG 200 NPT	Female 800801018	-	2"	G	241,5	9,51	F	156,6	6,17	C	80,0	3,15	I	88,5	3,48	E	100,0	3,94	5,10	11,24
	M FIRG 200 NPT	Male 800801019						D	123,8	4,87	B	75,0	2,95	H	83,5	3,29	J	73,0	2,87	2,26	4,98

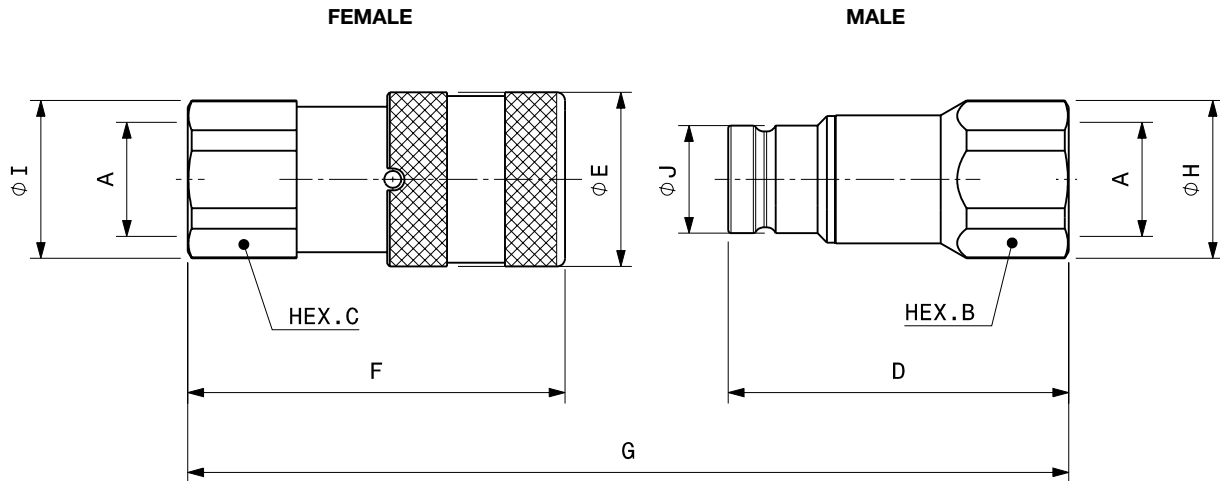
Port description: FEMALE THREAD SAE (ISO 11926-1 & SAE J1926-1)

BODY SIZE	Descriptive Code	Item Code	ISO DN	PORT (A)	Overall Length		Length			Hex		Diameter		Diameter		Weight					
					mm	inch	mm	inch	mm	inch	mm	inch	mm	inch	Kg	Lbs					
1/4"	F FIRG 14 3/8 SAE	Female 800804000	6,3	9/16-18UNF	G	93,2	3,67	F	53,1	2,09	C	22,0	0,87	I	23,8	0,94	E	28,0	1,10	0,15	0,33
	M FIRG 14 3/8 SAE	Male 800804001						D	50,9	2,00	B	22,0	0,87	H	23,8	0,94	J	16,1	0,63	0,09	0,20
3/8"	F FIRG 38 1/2 SAE	Female 800804002	10	3/4-16UNF	G	116,2	4,57	F	69,2	2,72	C	27,0	1,06	I	29,0	1,14	E	32,0	1,26	0,24	0,54
	M FIRG 38 1/2 SAE	Male 800804003						D	62,5	2,46	B	27,0	1,06	H	29,0	1,14	J	19,7	0,78	0,14	0,31
3/8"	F FIRG 12 5/8 SAE	Female 800804004	10	7/8-14UNF	G	119,7	4,71	F	71,2	2,80	C	30,0	1,18	I	32,0	1,26	E	32,0	1,26	0,26	0,57
	M FIRG 12 5/8 SAE	Male 800804005						D	64,0	2,52	B	30,0	1,18	H	32,0	1,26	J	19,7	0,78	0,15	0,32
1/2"	F FIRG 12A 5/8 SAE	Female 800804006	12,5	7/8-14UNF	G	129,0	5,08	F	76,3	3,00	C	32,0	1,26	I	33,8	1,33	E	38,0	1,50	0,38	0,83
	M FIRG 12A 5/8 SAE	Male 800804007						D	70,0	2,76	B	32,0	1,26	H	33,8	1,33	J	24,5	0,96	0,23	0,51
1/2"	F FIRG 34 SAE	Female 800804008	12,5	1-1/16-12UN	G	138,0	5,43	F	83,3	3,28	C	36,0	1,42	I	38,5	1,52	E	38,0	1,50	0,42	0,93
	M FIRG 34 SAE	Male 800804009						D	72,0	2,83	B	36,0	1,42	H	38,5	1,52	J	24,5	0,96	0,23	0,51
5/8"	F FIRG 34B SAE	Female 800804010	16	1-1/16-12UN	G	137,9	5,43	F	83,5	3,29	C	36,0	1,42	I	38,5	1,52	E	42,0	1,65	0,50	1,10
	M FIRG 34B SAE	Male 800804011						D	72,0	2,83	B	36,0	1,42	H	38,5	1,52	J	27,0	1,06	0,27	0,59
3/4"	F FIRG 34A SAE	Female 800804020	19	1-1/16-12UN	G	149,0	5,87	F	88,7	3,49	C	41,0	1,61	I	44,8	1,76	E	48,0	1,89	0,75	1,64
	M FIRG 34A SAE	Male 800804021						D	82,3	3,24	B	41,0	1,61	H	44,8	1,76	J	30,0	1,18	0,44	0,97
3/4"	F FIRG 100 SAE	Female 800804012	19	1-5/16-12UN	G	153,5	6,04	F	93,2	3,67	C	45,0	1,77	I	47,8	1,88	E	48,0	1,89	0,77	1,69
	M FIRG 100 SAE	Male 800804013						D	82,3	3,24	B	45,0	1,77	H	47,8	1,88	J	30,0	1,18	0,39	0,87
1"	F FIRG 114 SAE	Female 800804014	25	1-5/8-12UN	G	172,8	6,80	F	106,0	4,17	C	55,0	2,17	I	59,8	2,35	E	55,0	2,17	1,22	2,68
	M FIRG 114 SAE	Male 800804015						D	89,8	3,54	B	55,0	2,17	H	59,8	2,35	J	36,0	1,42	0,64	1,41
1-1/2"	F FIRG 112 SAE	Female 800804016	-	1-7/8-12UN	G	214,9	8,46	F	132,4	5,21	C	65,0	2,56	I	72,0	2,83	E	80,0	3,15	2,82	6,22
	M FIRG 112 SAE	Male 800804017						D	111,1	4,37	B	65,0	2,56	H	69,8	2,75	J	57,0	2,24	1,66	3,65
2"	F FIRG 200 SAE	Female 800804018	-	2-1/2-12UN	G	241,5	9,51	F	156,6	6,17	C	80,0	3,15	I	88,5	3,48	E	100,0	3,94	5,10	11,24
	M FIRG 200 SAE	Male 800804019						D	123,8	4,87	B	75,0	2,95	H	83,5	3,29	J	73,0	2,87	2,26	4,98

Panel mounting

FIRG Series is available upon request also as panel mounting version:

 BC: Snap Ring Solution
 Grooves on the male body and on the female sleeve.

 BT: Lock Ring Solution
 Thread on the male body and female body.

SS version

For specific cases, FIRG Series is available upon request without the safety lock ball.

For additional information, please contact Stucchi Technical Support.

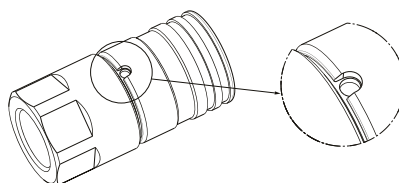



SPARE KIT SEAL FOR MALE

Repair kit / OR+BK		
Body Size	Description	Part Number
1/4"	M FIRG14	815700519
3/8"	M FIRG38-12	815700337
1/2"	M FIRG12A-34	815700339
5/8"	M FIRG34B	815700341
3/4"	M FIRG100-34A	815700343
1"	M FIRG114	815700345
1-1/2"	M FIRG112	815700521
2"	M FIRG200	815700796

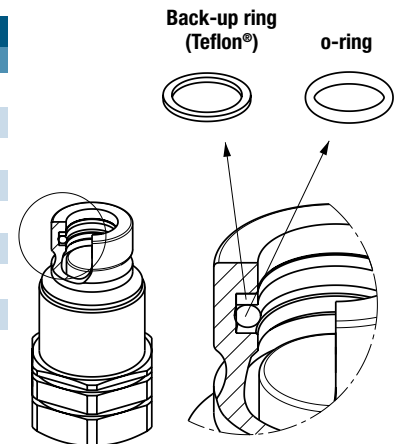

O-Ring in Nitrile
BackUp in Teflon®

PROTECTIVE CAPS FOR FIRG SERIES

Protective caps are always recommended to protect the couplings from damage, dirt inclusion, and will increase the product life. This is particularly important in mobile applications where exposure to weather and aggregate materials are common.

For the FIRG series are available three kind of materials:

- plastic caps with lanyard (standard color: red, other colors available upon request)
- aluminum caps with lanyard (standard colors: natural aluminum, other colors available upon request)
- plastic caps, clip system (standard color: red, other colors available upon request)

Cap for MALE coupling Plastic

Cap for FEMALE coupling Plastic

Body Size/Description	Protective Cap		Material/Color
	Part Number		
	Cap for Female	Cap for Male	
1/4" FIRG14	815100000	815100023	Plastic/Red
3/8" FIRG38-12	815100002	815100025/027	Plastic/Red
1/2" FIRG12A-34	815100004/006	815100029/031	Plastic/Red
5/8" FIRG34B	815100008	815100011	Plastic/Red
3/4" FIRG100-34A	815100010	815100013	Plastic/Red
1" FIRG114	815100012	815100015	Plastic/Red

Cap for FEMALE coupling Aluminium

Cap for MALE coupling Aluminium

Body Size/Description	Protective Cap		Material/Color
	Part Number		
	Cap for Female	Cap for Male	
1/4" FIRG14	816005002	816005003	Aluminum/Natural
3/8" FIRG38-12	816005004	816005005	Aluminum/Natural
1/2" FIRG12A-34	816005006	816005007	Aluminum/Natural
3/4" FIRG100-34A	816005010	816005011	Aluminum/Natural
1" FIRG114	816005012	816005013	Aluminum/Natural
1-1/2" FIRG112	815105014	815105017	Aluminum/Natural
2" FIRG200	815105016	815105019	Aluminum/Natural

Flip cap for FEMALE coupling Plastic

Close **Open**

Body Size/Description	Protective Cap		Material/Color
	Part Number		
	Cap for Female		
3/8" FIRG38-12	815200002		Plastic/Red
1/2" FIRG12A-34	815200004		Plastic/Red
5/8" FIRG34B	815200006		Plastic/Red
3/4" FIRG100-34A	815200008		Plastic/Red



A SERIES

INTERCHANGE > ISO 16028 - NFPA T3.20.15 - HTMA (size 3/8")















Stucchi®

FLAT FACE



TECHNICAL FEATURES AND OPTIONS

 Interchange ISO 16028 NFPA T3.20.15 HTMA (size 3/8")	 Sealing description Nitrile NBR	 Connection system Push
 Available sizes from 1/8" to 1-1/2"	 Material/treatment Carbon steel/ Cr3 (Zn-Ni version available)	 Available threads BSP - NPT - SAE ORFS - METRIC - JIC
 Operating pressure Up to 420 bar	 Locking mechanism Locking ball + Safety Lock	 Flow rate Up to 750 l/min
 Temperature (°C) -20° / +100°	 Valving style Flat face	 Connection under pressure Connection: not allowed Disconnection: not allowed

BENEFITS

- Flat face is easy to clean, reducing the inclusion of contamination inside the hydraulic circuit.
- Minimal fluid spillage during disconnection, reducing fluid spillage to the environment.
- Minimal air inclusion during connection.
- Internal valve design creates minimal pressure drop, maintaining circuit efficiency in the system
- The modular design allows flexibility with a wide range of configurations.
- Good resistance to pressure impulses.
- Compact slim design.
- Safe and simple to use.

HOW TO USE

- Before to connect, clean the mating surface of the couplings to avoid dirt inclusion in the circuit.
- To connect push the male half towards the female half or vice versa.
- After connection turn the external sleeve to engage safety lock function, to prevent accidental disconnection.
- To disconnect turn the external sleeve until the sleeve lock notch match the safety lock ball and push back the sleeve.

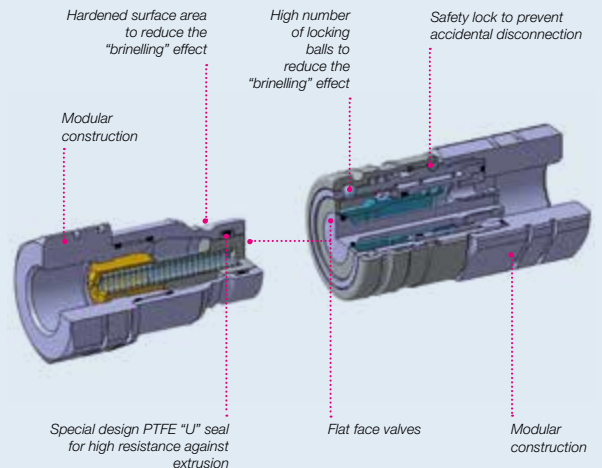
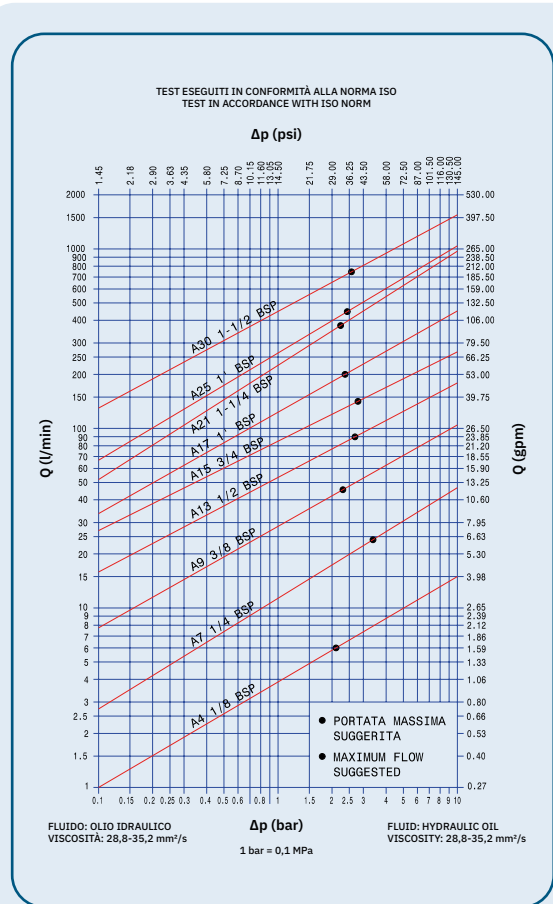

MAIN APPLICATIONS

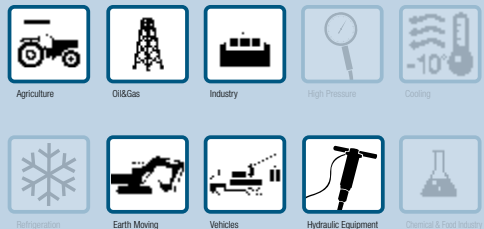

PERFORMANCES

Size		Series/Size	Max. flow suggested		Connect force		Disconnect force		Spillage*
Inch	mm (ISO)		l/min	gpm	N	lbf	N	lbf	ml
1/8	-	A4	6	1,59	120	27,00	25	5,63	-
1/4	6,3	A7	24	6,36	150	33,75	45	10,13	0,01
3/8	10,0	A9	46	12,19	170	38,25	40	9,00	0,01
1/2	12,5	A13	90	23,85	190	42,75	50	11,25	0,02
5/8	16,0	A15	148	39,22	190	42,75	55	12,38	0,02
3/4	19,0	A17	200	53,00	220	49,50	70	15,75	0,03
1	25,0	A21	378	100,17	250	56,25	75	16,88	0,03
1-1/4	-	A25	450	119,25	350	78,75	90	20,25	0,17
1-1/2	-	A30	750	198,75	390	87,75	70	15,75	0,05

Size	Series/Size	Max. operating pressure						Burst pressure					
		Coupled		Male		Female		Coupled		Male		Female	
Inch		MPa	psi	MPa	psi	MPa	psi	MPa	psi	MPa	psi	MPa	psi
1/8	A4	42	6090	42	6090	42	6090	126	18270	126	18270	126	18270
1/4	A7	42	6090	42	6090	42	6090	126	18270	126	18270	126	18270
3/8	A9	35	5075	35	5075	35	5075	100	14500	100	14500	100	14500
1/2	A13	33	4785	33	4785	33	4785	100	14500	100	14500	100	14500
5/8	A15	33	4785	33	4785	33	4785	100	14500	100	14500	100	14500
3/4	A17	33	4785	33	4785	33	4785	100	14500	100	14500	100	14500
1	A21	30	4350	30	4350	30	4350	80	11600	80	11600	80	11600
1-1/4	A25	30	4350	30	4350	30	4350	80	11600	80	11600	80	11600
1-1/2	A30	27	3915	27	3915	27	3915	80	11600	80	11600	70	10150

* Spillage is an indicative value of the fluid loss during disconnection (according to ISO norm test method).

Different possible configurations:
Different threads available upon request.

Temperature range:

Standard seals NBR (Nitrile): from -20 °C to +100 °C (from -4 °F to +212 °F).
Upon request seals in VITON®: from -15°C to +180°C (from +5 °F to +356 °F).
Please read carefully Instructions and warnings for proper selection of the products.

Tests:

The couplings have been tested at max. operating pressure for 100.000 impulses according to ISO norm.

! WARNING

A defect, a wrong choice or an improper use of products, can cause injury to persons, animals and objects.

Never connect or disconnect with dynamic pressure (e.g. pump on).

Do not use the female coupling disconnected with high impulse pressure.

Do not couple-uncouple with flow and/or pressure in the circuit.

Do not couple-uncouple when the temperature inside of the circuit is higher than 80 °C (176 °F).

Check the maximum allowable working pressure of the port in use.

Make sure that the medium used is compatible with seal and material as indicated for each series.

In case of doubt please contact Stucchi Technical Support.

The interchangeability is mentioned under the assumption that the manufacturer of the considered products has not changed any dimension.

It is mandatory to carefully read and closely follow the instructions before selecting or using any Stucchi products.

Always refer to the version uploaded in the Instructions and warning section of stucchigroup.com website for the latest release.

For specific, product-related, instructions, please contact Stucchi technical service.

OVERALL DIMENSIONS

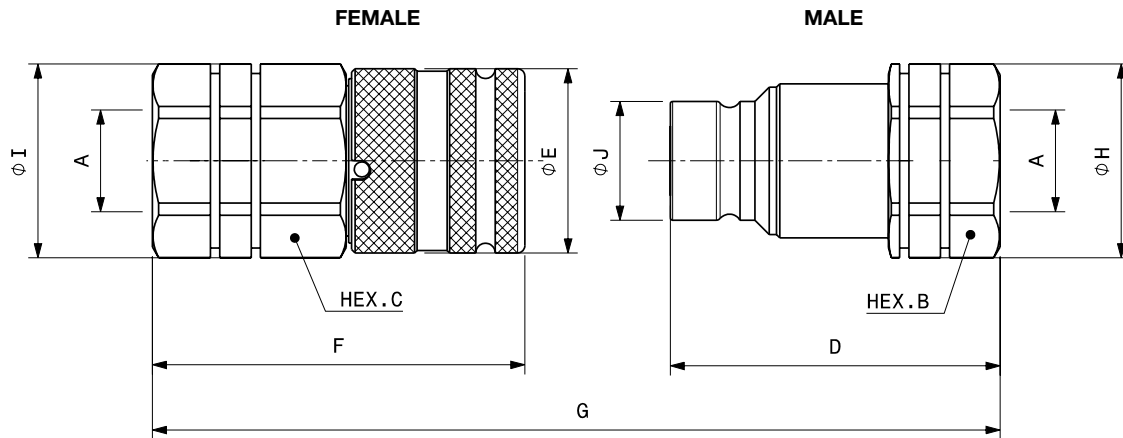

Port description: FEMALE THREAD BSPP (ISO 1179-1)

BODY SIZE	Descriptive Code	Item Code	ISO DN	PORT (A)	Overall Length	Length		Hex		Diameter		Diameter		Weight							
						mm	inch	mm	inch	mm	inch	mm	inch	mm	inch	Kg	Lbs				
1/8"	F A4 1/8 BSP	Female 801300002	-	1/8"	G	68,4	2,69	F	40,0	1,57	C	19,0	0,75	I	20,5	0,81	E	20,0	0,79	0,07	0,16
	M A4 1/8 BSP	Male 801300003						D	36,3	1,43	B	17,0	0,67	H	18,5	0,73	J	11,6	0,46	0,04	0,08
1/4"	F A7 1/4 BSP	Female 801300004	6,3	1/4"	G	90,2	3,55	F	53,1	2,09	C	27,0	1,06	I	29,0	1,14	E	28,0	1,10	0,19	0,41
	M A7 1/4 BSP	Male 801300031						D	47,9	1,89	B	22,0	0,87	H	23,8	0,94	J	16,1	0,63	0,09	0,19
3/8"	F A9 3/8 BSP	Female 801300006	10	3/8"	G	108,8	4,28	F	64,8	2,55	C	30,0	1,18	I	32,0	1,26	E	32,0	1,26	0,27	0,60
	M A9 3/8 BSP	Male 801300005						D	60,0	2,36	B	27,0	1,06	H	29,0	1,14	J	19,7	0,78	0,15	0,32
3/8"	F A9 1/2 BSP	Female 801300008	10	1/2"	G	116,3	4,58	F	69,8	2,75	C	30,0	1,18	I	32,0	1,26	E	32,0	1,26	0,28	0,61
	M A9 1/2 BSP	Male 801300007						D	62,5	2,46	B	27,0	1,06	H	29,0	1,14	J	19,7	0,78	0,14	0,30
1/2"	F A13 1/2 BSP	Female 801300014	12,5	1/2"	G	127,5	5,02	F	76,8	3,02	C	36,0	1,42	I	40,0	1,57	E	38,0	1,50	0,45	1,00
	M A13 1/2 BSP	Male 801300013						D	68,0	2,68	B	36,0	1,42	H	40,0	1,57	J	24,5	0,96	0,24	0,52
1/2"	F A13 3/4 BSP	Female 801300016	12,5	3/4"	G	137,0	5,39	F	83,8	3,30	C	36,0	1,42	I	40,0	1,57	E	38,0	1,50	0,46	1,02
	M A13 3/4 BSP	Male 801300015						D	70,5	2,78	B	36,0	1,42	H	40,0	1,57	J	24,5	0,96	0,27	0,60
5/8"	F A15 3/4 BSP	Female 801300022	16	3/4"	G	139,4	5,49	F	84,0	3,31	C	41,0	1,61	I	44,8	1,76	E	42,0	1,65	0,63	1,38
	M A15 3/4 BSP	Male 801300021						D	73,0	2,87	B	36,0	1,42	H	38,5	1,52	J	27,0	1,06	0,30	0,66
5/8"	F A15 1 BSP	Female 801300034	16	1"	G	145,4	5,72	F	87,0	3,43	C	41,0	1,61	I	44,8	1,76	E	42,0	1,65	0,60	1,32
	M A15 1 BSP	Male 801300035						D	76,0	2,99	B	41,0	1,61	H	44,8	1,76	J	27,0	1,06	0,33	0,73
3/4"	F A17 3/4 BSP	Female 801300040	19	3/4"	G	158,5	6,24	F	96,8	3,81	C	46,0	1,81	I	49,8	1,96	E	48,0	1,89	0,97	2,14
	M A17 3/4 BSP	Male 801300041						D	83,7	3,30	B	46,0	1,81	H	49,8	1,96	J	30,0	1,18	0,53	1,16
3/4"	F A17 1 BSP	Female 801300000	19	1"	G	160,5	6,32	F	98,8	3,89	C	46,0	1,81	I	49,8	1,96	E	48,0	1,89	0,94	2,07
	M A17 1 BSP	Male 801300001						D	83,7	3,30	B	46,0	1,81	H	49,8	1,96	J	30,0	1,18	0,48	1,05
1"	F A21 3/4 BSP	Female 801300048	25	3/4"	G	178,0	7,01	F	102,8	4,05	C	55,0	2,17	I	59,8	2,35	E	55,0	2,17	1,44	3,16
	M A21 3/4 BSP	Male 801300049						D	98,2	3,87	B	55,0	2,17	H	59,8	2,35	J	36,0	1,42	0,97	2,14
1"	F A21 1 BSP	Female 801300050	25	1"	G	178,6	7,03	F	104,8	4,13	C	55,0	2,17	I	59,8	2,35	E	55,0	2,17	1,42	3,12
	M A21 1 BSP	Male 801300051						D	96,8	3,81	B	55,0	2,17	H	59,8	2,35	J	36,0	1,42	0,89	1,96
1"	F A21 1-1/4 BSP	Female 801300024	25	1 1/4"	G	172,8	6,80	F	105,8	4,17	C	55,0	2,17	I	59,8	2,35	E	55,0	2,17	1,31	2,89
	M A21 1-1/4 BSP	Male 801300023						D	90,0	3,54	B	55,0	2,17	H	59,8	2,35	J	36,0	1,42	0,71	1,56
1"	F A21 1-1/2 BSP	Female 801300028	25	1 1/2"	G	182,8	7,20	F	110,8	4,36	C	60,0	2,36	I	64,8	2,55	E	55,0	2,17	1,40	3,08
	M A21 1-1/2 BSP	Male 801300027						D	95,0	3,74	B	60,0	2,36	H	64,8	2,55	J	36,0	1,42	0,80	1,76
1-1/4"	F A25 1 BSP	Female 801300046	-	1"	G	196,8	7,75	F	120,1	4,73	C	55,0	2,17	I	65,0	2,56	E	65,0	2,56	2,09	4,61
	M A25 1 BSP	Male 801300047						D	100,0	3,94	B	55,0	2,17	H	59,8	2,35	J	44,0	1,73	1,13	2,49
1-1/4"	F A25 1-1/4 BSP	Female 801300052	-	1 1/4"	G	206,8	8,14	F	125,1	4,93	C	55,0	2,17	I	65,0	2,56	E	65,0	2,56	2,07	4,56
	M A25 1-1/4 BSP	Male 801300053						D	105,0	4,13	B	55,0	2,17	H	59,8	2,35	J	44,0	1,73	1,09	2,39
1-1/2"	F A30 1-1/4 BSP	Female 801300036*	-	1-1/4"	G	214,9	8,46	F	132,4	5,21	C	65,0	2,56	I	69,8	2,75	E	80,0	3,15	3,25	7,16
	M A30 1-1/4 BSP	Male 801300037*						D	111,1	4,37	B	65,0	2,56	H	82,0	3,23	J	57,0	2,24	1,75	3,85
1-1/2"	F A30 1-1/2 BSP	Female 801300026	-	1 1/2"	G	214,9	8,46	F	132,4	5,21	C	65,0	2,56	I	82,0	3,23	E	80,0	3,15	3,14	6,92
	M A30 1-1/2 BSP	Male 801300025						D	111,1	4,37	B	65,0	2,56	H	69,8	2,75	J	57,0	2,24	1,67	3,67
1-1/2"	F A30 2 BSP	Female 801300038	-	2"	G	228,4	8,99	F	138,0	5,43	C	75,0	2,95	I	82,0	3,23	E	80,0	3,15	3,33	7,33
	M A30 2 BSP	Male 801300039						D	119,0	4,69	B	75,0	2,95	H	82,0	3,23	J	57,0	2,24	1,93	4,25

* Available upon request.

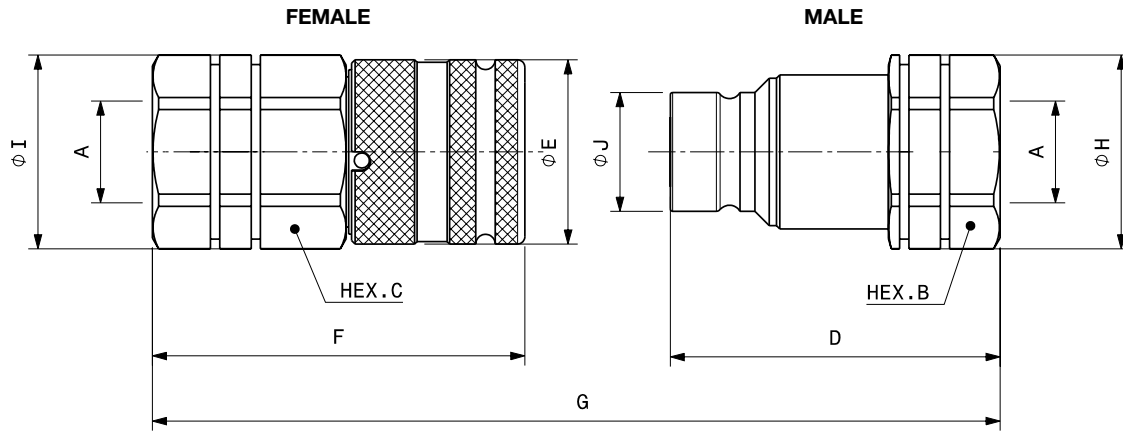

Port description: FEMALE THREAD NPT (ANSI B1.20.1)

BODY SIZE	Descriptive Code	Item Code	ISO DN	PORT (A)	Overall Length		Length		Hex		Diameter		Diameter		Weight						
					mm	inch	mm	inch	mm	inch	mm	inch	mm	inch	Kg	Lbs					
1/8"	F A4 1/8 NPT	Female 801301002		1/8"	G	68,4	2,69	F	40,0	1,57	C	19,0	0,75	I	20,5	0,81	E	20,0	0,79	0,07	0,16
	M A4 1/8 NPT	Male 801301003						D	36,3	1,43	B	17,0	0,67	H	18,5	0,73	J	11,6	0,46	0,04	0,08
1/4"	F A7 1/4 NPT	Female 801301004	6,3	1/4"	G	90,2	3,55	F	53,1	2,09	C	27,0	1,06	I	29,0	1,14	E	28,0	1,10	0,19	0,41
	M A7 1/4 NPT	Male 801301023						D	47,9	1,89	B	22,0	0,87	H	23,8	0,94	J	16,1	0,63	0,09	0,19
3/8"	F A9 3/8 NPT	Female 801301006	10	3/8"	G	108,8	4,28	F	64,8	2,55	C	30,0	1,18	I	32,0	1,26	E	32,0	1,26	0,27	0,60
	M A9 3/8 NPT	Male 801301005						D	60,0	2,36	B	27,0	1,06	H	29,0	1,14	J	19,7	0,78	0,15	0,33
3/8"	F A9 1/2 NPT	Female 801301008	10	1/2"	G	116,3	4,58	F	69,8	2,75	C	30,0	1,18	I	32,0	1,26	E	32,0	1,26	0,28	0,61
	M A9 1/2 NPT	Male 801301007						D	62,5	2,46	B	27,0	1,06	H	29,0	1,14	J	19,7	0,78	0,14	0,30
1/2"	F A13 1/2 NPT	Female 801301010	12,5	1/2"	G	127,5	5,02	F	76,8	3,02	C	36,0	1,42	I	40,0	1,57	E	38,0	1,50	0,45	1,00
	M A13 1/2 NPT	Male 801301009						D	68,0	2,68	B	36,0	1,42	H	40,0	1,57	J	24,5	0,96	0,30	1,65
1/2"	F A13 3/4 NPT	Female 801301012	12,5	3/4"	G	137,0	5,39	F	83,8	3,30	C	36,0	1,42	I	40,0	1,57	E	38,0	1,50	0,47	1,03
	M A13 3/4 NPT	Male 801301011						D	70,5	2,78	B	36,0	1,42	H	40,0	1,57	J	24,5	0,96	0,27	0,60
5/8"	F A15 3/4 NPT	Female 801301014	16	3/4"	G	139,4	5,49	F	84,0	3,31	C	41,0	1,61	I	44,8	1,76	E	42,0	1,65	0,63	1,39
	M A15 3/4 NPT	Male 801301013						D	73,0	2,87	B	36,0	1,42	H	38,5	1,52	J	27,0	1,06	0,29	0,64
5/8"	F A15 1 NPT	Female 801301020	16	1"	G	145,4	5,72	F	87,0	3,43	C	41,0	1,61	I	44,8	1,76	E	42,0	1,65	0,61	1,33
	M A15 1 NPT	Male 801301019						D	76,0	2,99	B	41,0	1,61	H	44,8	1,76	J	27,0	1,06	0,34	0,74
3/4"	F A17 3/4 NPT	Female 801301030	19	3/4"	G	157,5	6,20	F	95,8	3,77	C	46,0	1,81	I	49,8	1,96	E	48,0	1,89	0,96	2,12
	M A17 3/4 NPT	Male 801301031						D	83,7	3,30	B	46,0	1,81	H	49,8	1,96	J	30,0	1,18	0,54	1,18
3/4"	F A17 1 NPT	Female 801301000	19	1"	G	160,5	6,32	F	98,8	3,89	C	46,0	1,81	I	49,8	1,96	E	48,0	1,89	0,93	2,05
	M A17 1 NPT	Male 801301001						D	83,7	3,30	B	46,0	1,81	H	49,8	1,96	J	30,0	1,18	0,47	1,04
1"	F A21 1 NPT	Female 801301028	25	1"	G	178,6	7,03	F	104,8	4,13	C	55,0	2,17	I	59,8	2,35	E	55,0	2,17	1,43	3,15
	M A21 1 NPT	Male 801301029						D	96,8	3,81	B	55,0	2,17	H	59,8	2,35	J	36,0	1,42	0,90	1,98
1"	F A21 1-1/4 NPT	Female 801301016	25	1-1/4"	G	172,8	6,80	F	105,8	4,17	C	55,0	2,17	I	59,8	2,35	E	55,0	2,17	1,31	2,89
	M A21 1-1/4 NPT	Male 801301015						D	90,0	3,54	B	55,0	2,17	H	59,8	2,35	J	36,0	1,42	0,70	1,54
1"	F A21 1-1/2 NPT	Female 801301026 *	25	1-1/2"	G	182,8	7,20	F	110,8	4,36	C	60,0	2,36	I	64,8	2,55	E	55,0	2,17	1,37	3,01
	M A21 1-1/2 NPT	Male 801301027 *						D	95,0	3,74	B	60,0	2,36	H	64,8	2,55	J	36,0	1,42	0,75	1,66
1-1/4"	F A25 1 NPT	Female 801301032 *	-	1"	G	206,8	8,14	F	125,1	4,93	C	55,0	2,17	I	65,0	2,56	E	65,0	2,56	2,09	4,61
	M A25 1 NPT	Male 801301033 *						D	105,0	4,13	B	55,0	2,17	H	59,8	2,35	J	44,0	1,73	1,13	2,49
1-1/4"	F A25 1-1/4 NPT	Female 801301034	-	1-1/4"	G	206,8	8,14	F	125,1	4,93	C	55,0	2,17	I	65,0	2,56	E	65,0	2,56	2,10	4,63
	M A25 1-1/4 NPT	Male 801301035						D	105,0	4,13	B	55,0	2,17	H	59,8	2,35	J	44,0	1,73	1,11	2,44
1-1/2"	F A30 1-1/2 NPT	Female 801301018	-	1-1/2"	G	214,9	8,46	F	132,4	5,21	C	65,0	2,56	I	82,0	3,23	E	80,0	3,15	3,14	6,92
	M A30 1-1/2 NPT	Male 801301017						D	111,1	4,37	B	65,0	2,56	H	69,8	2,75	J	57,0	2,24	1,67	3,67
1-1/2"	F A30 2 NPT	Female 801301024	-	2"	G	228,4	8,99	F	138,0	5,43	C	75,0	2,95	I	82,0	3,23	E	80,0	3,15	3,25	7,17
	M A30 2 NPT	Male 801301025						D	119,0	4,69	B	75,0	2,95	H	82,0	3,23	J	57,0	2,24	1,94	4,28

* Available upon request.

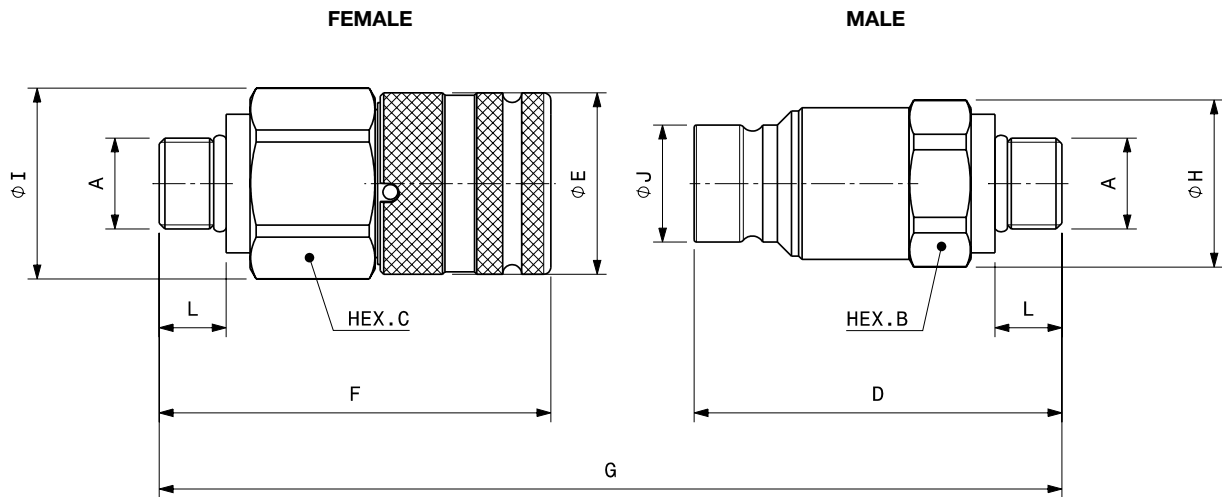
Port description: MALE THREAD SAE – (ISO 11926-2 & SAE J514)

BODY SIZE	Descriptive Code	Item Code	ISO DN	PORT (A)	Overall Length		Length		Hex		Diameter		Diameter		Lenght		Weight							
					mm	inch	mm	inch	mm	inch	mm	inch	mm	inch	mm	inch	Kg	Lbs						
1/4"	F A7 3/8 SAE EST	Female 801304020 *	6,3	9/16 -18UNF	G	-	-	F	-	-	C	-	-	I	-	-	E	-	-	L	10,0	0,39	-	-
	M A7 3/8 SAE EST	Male 801304021 *				D	51,9	2,04	B	22,0	0,87	H	23,8	0,94	J	16,1	0,63	-	-	-	-			
3/8"	F A9 3/8 SAE EST	Female 801304036 *	10	9/16 - 18UNF	G	-	-	F	-	-	C	-	-	I	-	-	E	-	-	L	9,9	0,39	-	-
	M A9 3/8 SAE EST	Male 801304037 *				D	65,5	2,58	B	27,0	1,06	H	29,0	1,14	J	19,7	0,78	-	-	-	-			
3/8"	F A9 1/2 SAE EST	Female 801304032	10	3/4 - 16UNF	G	116,8	4,60	F	68,7	2,70	C	30,0	1,18	I	32,0	1,26	E	32,0	1,26	L	11,1	0,44	0,26	0,57
	M A9 1/2 SAE EST	Male 801304033				D	64,1	2,52	B	27,0	1,06	H	29,0	1,14	J	19,7	0,78	-	-	-	-			
1/2"	F A13 5/8 SAE EST	Female 801304046 *	12,5	7/8 - 14UNF	G	-	-	F	-	-	C	-	-	I	-	-	E	-	-	L	12,7	0,50	-	-
	M A13 5/8 SAE EST	Male 801304047 *				D	72,7	2,86	B	36,0	1,42	H	40,0	1,57	J	24,5	0,96	-	-	-	-			
5/8"	F A15 3/4 SAE EST	Female 801304022 *	16	1-1/16-12UN	G	140,1	5,52	F	82,6	3,25	C	41,0	1,61	I	44,8	1,76	E	42,0	1,65	L	15,1	0,59	0,56	1,23
	M A15 3/4 SAE EST	Male 801304023 *				D	75,1	2,96	B	36,0	1,42	H	38,5	1,52	J	27,0	1,06	-	-	-	-			

* Available upon request.

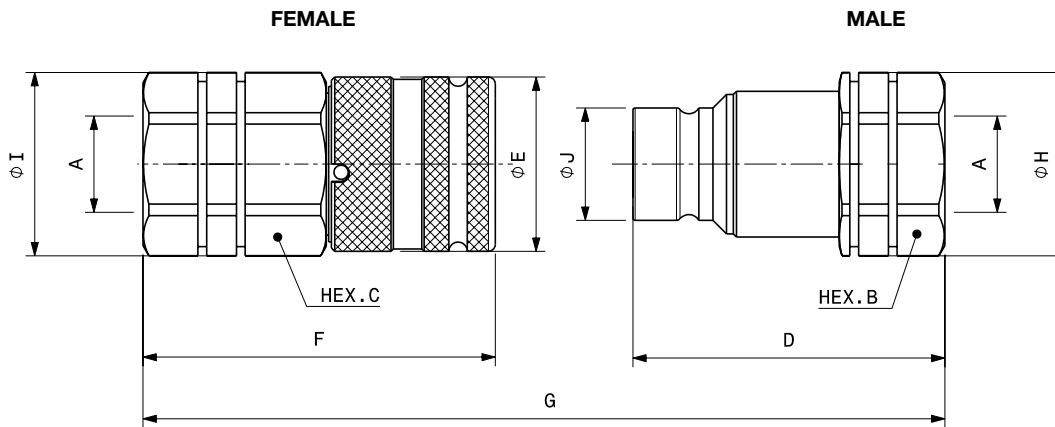

Port description: FEMALE THREAD SAE (ISO 11926-1 & SAEJ1926-1)

BODY SIZE	Descriptive Code	Item Code	ISO DN	PORT (A)	Overall Length	Length		Hex		Diameter		Diameter		Weight							
						mm	inch	mm	inch	mm	inch	mm	inch	mm	inch	Kg	Lbs				
1/8"	F A4 3/16 SAE	Female 801304002	-	3/8-24UNF	G	68,4	2,69	F	40,0	1,57	C	19,0	0,75	I	20,5	0,81	E	20,0	0,79	0,08	0,17
	M A4 3/16 SAE	Male 801304003	-	3/8-24UNF	G	68,4	2,69	D	36,3	1,43	B	17,0	0,67	H	18,5	0,73	J	11,6	0,46	0,04	0,08
1/8"	F A4 1/4 SAE	Female 801304044	-	7/16 - 20UNF	G	84,3	3,32	F	44,0	1,73	C	19,0	0,75	I	20,5	0,81	E	20,0	0,79	0,08	0,17
	M A4 1/4 SAE	Male 801304045	-	7/16 - 20UNF	G	84,3	3,32	D	40,3	1,59	B	17,0	0,67	H	18,5	0,73	J	11,6	0,46	0,04	0,09
1/4"	F A7 3/8 SAE	Female 801304004	6,3	9/16-18UNF	G	96,2	3,79	F	56,1	2,21	C	27,0	1,06	I	29,0	1,14	E	28,0	1,10	0,20	0,44
	M A7 3/8 SAE	Male 801304017	6,3	9/16-18UNF	G	96,2	3,79	D	50,9	2,00	B	22,0	0,87	H	23,8	0,94	J	16,1	0,63	0,09	0,20
3/8"	F A9 3/8 SAE	Female 801304006	10	9/16-18UNF	G	108,8	4,28	F	64,8	2,55	C	30,0	1,18	I	32,0	1,26	E	32,0	1,26	0,27	0,60
	M A9 3/8 SAE	Male 801304005	10	9/16-18UNF	G	108,8	4,28	D	60,0	2,36	B	27,0	1,06	H	29,0	1,14	J	19,7	0,78	0,08	0,19
3/8"	F A9 1/2 SAE	Female 801304008	10	3/4-16UNF	G	116,3	4,58	F	69,8	2,75	C	30,0	1,18	I	32,0	1,26	E	32,0	1,26	0,29	0,63
	M A9 1/2 SAE	Male 801304007	10	3/4-16UNF	G	116,3	4,58	D	62,5	2,46	B	27,0	1,06	H	29,0	1,14	J	19,7	0,78	0,15	0,32
3/8"	F A9 5/8 SAE	Female 801304030	10	7/8-14UNF	G	121,3	4,78	F	71,8	2,83	C	30,0	1,18	I	32,0	1,26	E	32,0	1,26	0,28	0,61
	M A9 5/8 SAE	Male 801304031	10	7/8-14UNF	G	121,3	4,78	D	65,5	2,58	B	30,0	1,18	H	32,0	1,26	J	19,7	0,78	0,17	0,36
1/2"	F A13 5/8 SAE	Female 801304024	12,5	7/8-14UNF	G	131,5	5,18	F	78,8	3,10	C	36,0	1,42	I	40,0	1,57	E	38,0	1,50	0,46	1,01
	M A13 5/8 SAE	Male 801304025	12,5	7/8-14UNF	G	131,5	5,18	D	70,0	2,76	B	36,0	1,42	H	40,0	1,57	J	24,5	0,96	0,29	0,65
1/2"	F A13 3/4 SAE	Female 801304010	12,5	1-1/1612UN	G	139,0	5,47	F	83,8	3,30	C	36,0	1,42	I	40,0	1,57	E	38,0	1,50	0,46	1,02
	M A13 3/4 SAE	Male 801304009	12,5	1-1/1612UN	G	139,0	5,47	D	72,5	2,85	B	36,0	1,42	H	40,0	1,57	J	24,5	0,96	0,28	0,61
5/8"	F A15 3/4 SAE	Female 801304012	16	1-1/16-12UN	G	139,4	5,49	F	84,0	3,31	C	41,0	1,61	I	44,8	1,76	E	42,0	1,65	0,63	1,38
	M A15 3/4 SAE	Male 801304011	16	1-1/16-12UN	G	139,4	5,49	D	73,0	2,87	B	36,0	1,42	H	38,5	1,52	J	27,0	1,06	0,30	0,65
3/4"	F A17 3/4 SAE	Female 801304028	19	1-1/16-12UN	G	160,5	6,32	F	98,8	3,89	C	46,0	1,81	I	49,8	1,96	E	48,0	1,89	0,99	2,17
	M A17 3/4 SAE	Male 801304029	19	1-1/16-12UN	G	160,5	6,32	D	83,7	3,30	B	46,0	1,81	H	49,8	1,96	J	30,0	1,18	0,52	1,15
3/4"	F A17 1 SAE	Female 801304000	19	1-5/16-12UN	G	160,5	6,32	F	98,8	3,89	C	46,0	1,81	I	49,8	1,96	E	48,0	1,89	0,93	2,05
	M A17 1 SAE	Male 801304001	19	1-5/16-12UN	G	160,5	6,32	D	83,7	3,30	B	46,0	1,81	H	49,8	1,96	J	30,0	1,18	0,47	1,03
3/4"	F A17 1-1/4 SAE	Female 801304026*	19	1-5/8-12UN	G	191,1	7,52	F	103,3	4,07	C	55,0	2,17	I	59,8	2,35	E	48,0	1,89	0,00	0,00
	M A17 1-1/4 SAE	Male 801304027*	19	1-5/8-12UN	G	191,1	7,52	D	87,8	3,46	B	55,0	2,17	H	59,8	2,35	J	30,0	1,18	0,00	0,00
1"	F A21 1 SAE	Female 801304038	25	1-5/16-12UN	G	178,6	7,03	F	104,8	4,13	C	55,0	2,17	I	59,8	2,35	E	55,0	2,17	1,42	3,12
	M A21 1 SAE	Male 801304039	25	1-5/16-12UN	G	178,6	7,03	D	96,8	3,81	B	55,0	2,17	H	59,8	2,35	J	36,0	1,42	0,89	1,96
1"	F A21 1-1/4 SAE	Female 801304014	25	1-5/8-12UN	G	172,8	6,80	F	105,8	4,17	C	55,0	2,17	I	59,8	2,35	E	55,0	2,17	1,32	2,91
	M A21 1-1/4 SAE	Male 801304013	25	1-5/8-12UN	G	172,8	6,80	D	90,0	3,54	B	55,0	2,17	H	59,8	2,35	J	36,0	1,42	0,71	1,56
1-1/4"	F A25 1 SAE	Female 801304040*	-	1-5/16-12UN	G	206,8	8,14	F	125,1	4,93	C	55,0	2,17	I	65,0	2,56	E	65,0	2,56	2,09	4,61
	M A25 1 SAE	Male 801304041*	-	1-5/16-12UN	G	206,8	8,14	D	105,0	4,13	B	55,0	2,17	H	59,8	2,35	J	44,0	1,73	1,13	2,49
1-1/4"	F A25 1-1/4 SAE	Female 801304042	-	1-5/8-12UN	G	206,8	8,14	F	125,1	4,93	C	55,0	2,17	I	65,0	2,56	E	65,0	2,56	2,07	4,56
	M A25 1-1/4 SAE	Male 801304043	-	1-5/8-12UN	G	206,8	8,14	D	105,0	4,13	B	55,0	2,17	H	59,8	2,35	J	44,0	1,73	1,09	2,39
1-1/2"	F A30 1-1/2 SAE	Female 801304016	-	1-7/8-12UN	G	214,9	8,46	F	132,4	5,21	C	65,0	2,56	I	82,0	3,23	E	80,0	3,15	3,16	6,97
	M A30 1-1/2 SAE	Male 801304015	-	1-7/8-12UN	G	214,9	8,46	D	111,1	4,37	B	65,0	2,56	H	69,8	2,75	J	57,0	2,24	1,66	3,66

* Available upon request.

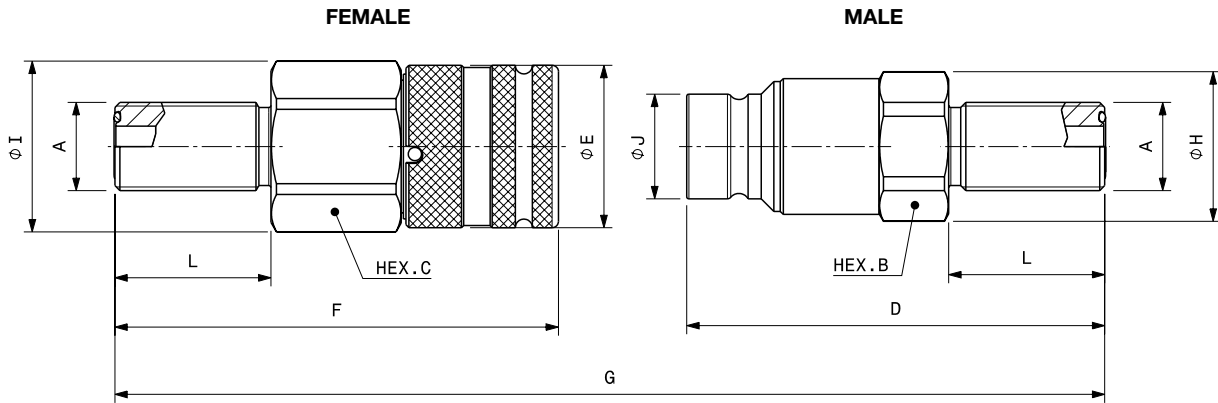

Port description: ORFS BULKHEAD (ISO 8434-3 & SAE J1453)

BODY SIZE	Descriptive Code	Item Code	ISO DN	PORT (A)	Overall Length		Length		Hex		Diameter		Diameter		Lenght		Weight							
					mm	inch	mm	inch	mm	inch	mm	inch	mm	inch	mm	inch	Kg	Lbs						
3/8"	F A9 3/8 ORFS BH	Female 801313014	10	11/16-16UN	G	169,3	6,67	F	95,1	3,74	C	30,0	1,18	I	32,0	1,26	E	32,0	1,26	L	34,0	1,34	0,32	0,71
	M A9 3/8 ORFS BH	Male 801313015						D	90,2	3,55	B	27,0	1,06	H	29,0	1,14	J	19,7	0,78					
1/2"	F A13 1/2 ORFS BH	Female 801313018	12,5	13/16-16UN	G	184,3	7,26	F	103,8	4,09	C	36,0	1,42	I	40,0	1,57	E	38,0	1,50	L	36,5	1,44	0,47	1,03
	M A13 1/2 ORFS BH	Male 801313019						D	97,8	3,85	B	32,0	1,26	H	35,0	1,38	J	24,5	0,96					
1/2"	F A13 5/8 ORFS BH33	Female 801313000	12,5	1-14UNS	G	171,7	6,76	F	96,0	3,78	C	36,0	1,42	I	40,0	1,57	E	38,0	1,50	L	33,0	1,30	0,46	1,02
	M A13 5/8 ORFS BH33	Male 801313001						D	93,0	3,66	B	32,0	1,26	H	35,0	1,38	J	24,5	0,96					
1/2"	F A13 3/4 ORFS BH	Female 801313004	12,5	1-3/16-12UN	G	189,1	7,44	F	104,7	4,12	C	36,0	1,26	I	40,0	1,57	E	38,0	1,50	L	41,7	1,64	0,52	2,34
	M A13 3/4 ORFS BH	Male 801313005						D	101,7	4,00	B	32,0	1,26	H	35,0	1,38	J	24,5	0,96					
1/2"	F A13 1 ORFS BH	Female 801313006	12,5	1-7/16-12UN	G	190,1	7,48	F	105,2	4,14	C	38,0	1,50	I	42,0	1,65	E	38,0	1,50	L	42,2	1,66	0,60	5,16
	M A13 1 ORFS BH	Male 801313007						D	102,2	4,02	B	38,0	1,50	H	42,0	1,65	J	24,5	0,96					
5/8"	F A15 3/4 ORFS BH	Female 801313022	16	1-3/16-12UN	G	196,4	7,73	F	111,5	4,39	C	41,0	1,61	I	44,8	1,76	E	42,0	1,65	L	41,5	1,63	0,69	1,52
	M A15 3/4 ORFS BH	Male 801313023						D	102,5	4,04	B	36,0	1,42	H	38,5	1,52	J	27,0	1,06					
3/4"	F A17 1 ORFS BH	Female 801313008	19	1-7/16-12UN	G	227,7	8,96	F	132,5	5,22	C	46,0	1,81	I	49,8	1,96	E	48,0	1,89	L	42,2	1,66	1,13	2,48
	M A17 1 ORFS BH	Male 801313009						D	117,2	4,61	B	46,0	1,81	H	49,8	1,96	J	30,0	1,18					
1"	F A21 1-1/4 ORFS BH	Female 801313026*	25	1-11/16-12UN	G	234,8	9,24	F	133,8	5,27	C	55,0	2,17	I	59,8	2,35	E	55,0	2,17	L	42,0	1,65	1,51	3,32
	M A21 1-1/4 ORFS BH	Male 801313027*						D	124,0	4,88	B	55,0	2,17	H	59,8	2,35	J	36,0	1,42					

* Available upon request.

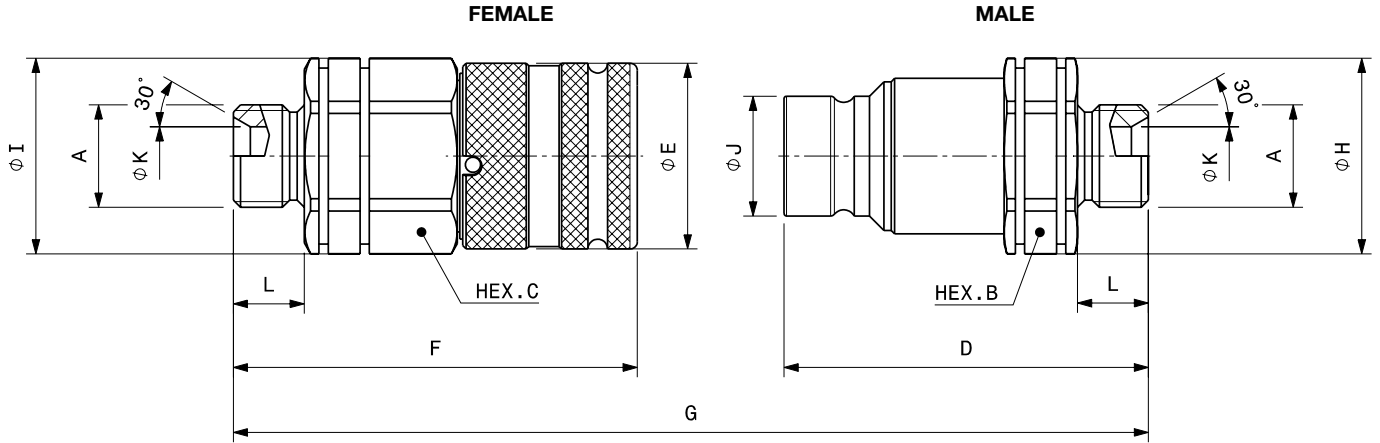

Port description: MALE THREAD BSPP (ISO 8434-6)

BODY SIZE	Descriptive Code	Item Code	ISO DN	PORT (A)	Overall Length	Length		Hex		Diameter		Diameter		Length		Weight						
						mm	inch	mm	inch	mm	inch	mm	inch	mm	inch	mm	inch	Kg	Lbs			
1/4"	F A7 1/4 BSP EST	Female 801300030	6,3	1/4"	G 95,2	F	53,1	2,09	C	27,0	1,06	I	29,0	1,14	E	28,0	1,10	L	11,0	0,43	0,16	0,34
	M A7 1/4 BSP EST	Male 801300029				D	52,9	2,08	B	22,0	0,87	H	23,8	0,94	J	16,1	0,63	L	11,0	0,43	0,08	0,18
3/8"	F A9 3/8 BSP EST	Female 801300010	10	3/8"	G 121,1	F	71,1	2,80	C	30,0	1,18	I	32,0	1,26	E	32,0	1,26	L	13,0	0,51	0,26	0,57
	M A9 3/8 BSP EST	Male 801300009				D	66,0	2,60	B	27,0	1,06	H	29,0	1,14	J	19,7	0,78	L	13,0	0,51	0,14	0,31
3/8"	F A9 1/2 BSP EST	Female 801300012	10	1/2"	G 122,6	F	71,1	2,80	C	30,0	1,18	I	32,0	1,26	E	32,0	1,26	L	14,5	0,57	0,26	0,57
	M A9 1/2 BSP EST	Male 801300011				D	67,5	2,66	B	27,0	1,06	H	29,0	1,14	J	19,7	0,78	L	14,5	0,57	0,15	0,33
1/2"	F A13 1/2 BSP EST	Female 801300018	12,5	1/2"	G 139,8	F	82,6	3,25	C	36,0	1,42	I	40,0	1,57	E	38,0	1,50	L	14,5	0,57	0,43	0,94
	M A13 1/2 BSP EST	Male 801300017				D	74,5	2,93	B	36,0	1,42	H	40,0	1,57	J	24,5	0,96	L	14,5	0,57	0,27	0,60
1/2"	F A13 3/4 BSP EST	Female 801300020*	12,5	3/4"	G 143,8	F	84,6	3,33	C	36,0	1,42	I	40,0	1,57	E	38,0	1,50	L	16,5	0,65	0,45	0,98
	M A13 3/4 BSP EST	Male 801300019*				D	76,5	3,01	B	36,0	1,42	H	40,0	1,57	J	24,5	0,96	L	16,5	0,65	0,29	0,63
5/8"	F A15 3/4 BSP EST	Female 801300032*	16	3/4"	G -	F	84,0	3,31	C	41,0	1,61	I	44,8	1,76	E	42,0	1,65	L	16,5	0,65	0,66	1,45
	M A15 3/4 BSP EST	Male 801300033*				D	-	-	B	-	-	H	-	-	J	-	-	L	16,5	0,65	-	-

* Available upon request.

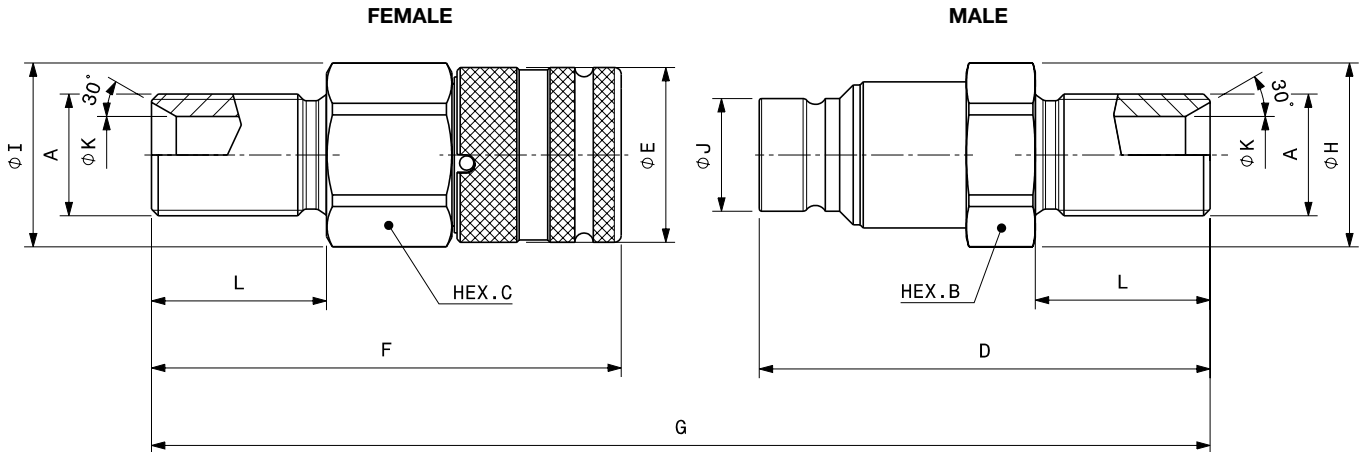

Port description: MALE THREAD BSPP scott and bulkhead (ISO 8434-6)

BODY SIZE	Descriptive Code	Item Code	ISO DN	PORT (A)	Overall Length	Length		Hex		Diameter		Diameter		Length		Weight						
						mm	inch	mm	inch	mm	inch	mm	inch	mm	inch	mm	inch	Kg	Lbs			
3/8"	F A9 3/8 BSP BH32	Female 801300044	10	3/8"	G 159,1	F	90,1	3,55	C	30,0	1,18	I	32,0	1,26	E	32,0	1,26	L	32,0	32,00	0,29	0,63
	M A9 3/8 BSP BH32	Male 801300045				D	85,0	3,35	B	27,0	1,06	H	29,0	1,14	J	19,7	0,78	L	32,0	32,00	0,16	0,35
3/8"	F A9 1/2 BSP BH35	Female 801300054*	10	1/2"	G 165,8	F	93,4	3,68	C	30,0	1,18	I	32,0	1,26	E	32,0	1,26	L	35,0	35,00	0,31	0,68
	M A9 1/2 BSP BH35	Male 801300055*				D	88,4	3,48	B	27,0	1,06	H	29,0	1,14	J	19,7	0,78	L	35,0	35,00	0,19	0,41
1/2"	F A13 3/4 BSP BH38	Female 801300056	12,5	3/4"	G 182,8	F	102,1	4,02	C	36,0	1,42	I	40,0	1,57	E	38,0	1,50	L	38,0	38,00	0,46	1,01
	M A13 3/4 BSP BH38	Male 801300057				D	98,0	3,86	B	36,0	1,42	H	40,0	1,57	J	24,5	0,96	L	38,0	38,00	0,33	0,73
3/4"	F A17 1 BSP BH41	Female 801300058	19	1"	G 221,3	F	127,3	5,01	C	46,0	1,81	I	49,8	1,96	E	48,0	1,89	L	41,0	41,00	1,00	2,19
	M A17 1 BSP BH41	Male 801300059				D	116,0	4,57	B	46,0	1,81	H	49,8	1,96	J	30,0	1,18	L	41,0	41,00	0,57	1,26

* Available upon request.

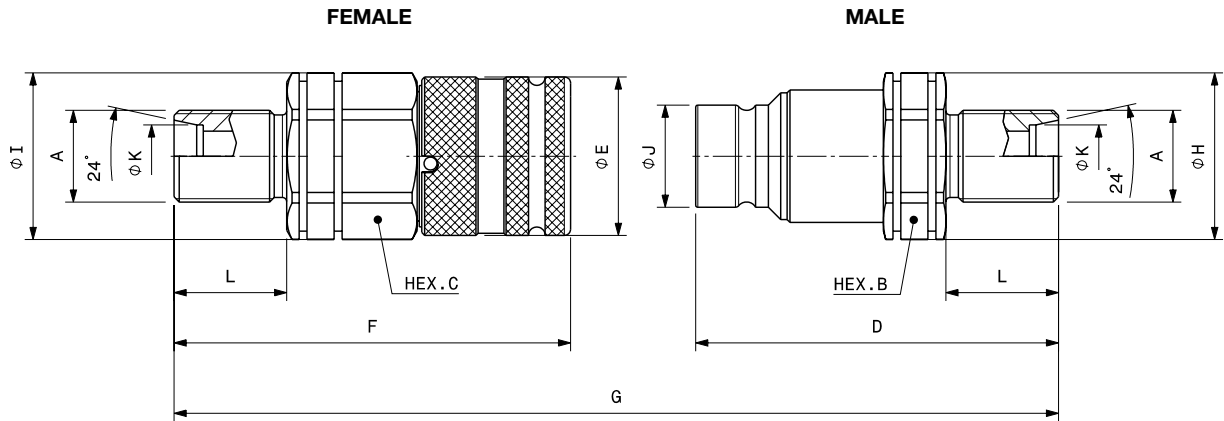

Port description: MALE THREAD L SERIES -24° CONE BULKHEAD (ISO 8434-1 & DIN 2353)

BODY SIZE	Descriptive Code	Item Code	ISO DN	PORT (A)	Overall Length	Length		Hex		Diameter		Diameter		Diameter		Length		Weight			
						mm	inch	mm	inch	mm	inch	mm	inch	mm	inch	mm	inch	mm	inch	Kg	Lbs
1/4"	F A7 L8 SCHOTT	Female 801310014	6,3	M14x1.5	G	123,2	4,85	F 67,1	2,64	C 27,0	1,06	I 29,0	1,14	E 28,0	1,10	K 8,2	0,32	L 25,0	0,98	0,17	0,36
	M A7 L8 SCHOTT	Male 801310015						D 66,9	2,63	B 22,0	0,87	H 23,8	0,94	J 16,1	0,63					0,10	0,21
1/4"	F A7 L10 SCHOTT	Female 801310010	6,3	M16x1.5	G	125,2	4,93	F 68,1	2,68	C 27,0	1,06	I 29,0	1,14	E 28,0	1,10	K 10,2	0,40	L 26,0	1,02	0,17	0,37
	M A7 L10 SCHOTT	Male 801310011						D 67,9	2,67	B 22,0	0,87	H 23,8	0,94	J 16,1	0,63					0,10	0,22
3/8"	F A9 L8 SCHOTT	Female 801310040*	10	M14x1.5	G	-	-	F -	-	C -	-	I -	-	E -	-	K 8,2	0,32	L 25,0	0,98	-	-
	M A9 L8 SCHOTT	Male 801310041*						D 79,5	3,13	B 30,0	1,18	H 32,0	1,26	J 19,7	0,78					0,16	0,36
3/8"	F A9 L10 SCHOTT	Female 801310008	10	M16x1.5	G	149,1	5,87	F 84,6	3,33	C 30,0	1,18	I 32,0	1,26	E 32,0	1,26	K 10,2	0,40	L 26,0	1,02	0,28	0,61
	M A9 L10 SCHOTT	Male 801310009						D 80,5	3,17	B 30,0	1,18	H 32,0	1,26	J 19,7	0,78					0,17	0,37
3/8"	F A9 L12 SCHOTT	Female 801310004	10	M18x1.5	G	147,1	5,79	F 82,6	3,25	C 30,0	1,18	I 32,0	1,26	E 32,0	1,26	K 12,2	0,48	L 26,0	1,02	0,27	0,59
	M A9 L12 SCHOTT	Male 801310005						D 80,5	3,17	B 30,0	1,18	H 32,0	1,26	J 19,7	0,78					0,17	0,38
3/8"	F A9 L15 SCHOTT	Female 801310006	10	M22x1.5	G	149,1	5,87	F 83,6	3,29	C 30,0	1,18	I 32,0	1,26	E 32,0	1,26	K 15,2	0,60	L 27,0	1,06	0,28	0,62
	M A9 L15 SCHOTT	Male 801310007						D 81,5	3,21	B 30,0	1,18	H 32,0	1,26	J 19,7	0,78					0,19	0,41
3/8"	F A9 L18 SCHOTT	Female 801310036	10	M26x1.5	G	149,1	5,87	F 83,6	3,29	C 30,0	1,18	I 32,0	1,26	E 32,0	1,26	K 18,2	0,72	L 27,0	1,06	0,31	0,67
	M A9 L18 SCHOTT	Male 801310037						D 81,5	3,21	B 30,0	1,18	H 32,0	1,26	J 19,7	0,78					0,21	0,45
1/2"	F A13 L12 SCHOTT	Female 801310000	12,5	M18x1.5	G	162,9	6,41	F 94,1	3,70	C 36,0	1,42	I 40,0	1,57	E 38,0	1,50	K 12,2	0,48	L 26,0	1,02	0,44	0,96
	M A13 L12 SCHOTT	Male 801310001						D 86,1	3,39	B 36,0	1,42	H 40,0	1,57	J 24,5	0,96					0,28	0,61
1/2"	F A13 L15 SCHOTT	Female 801310002	12,5	M22x1.5	G	164,9	6,49	F 95,1	3,74	C 36,0	1,42	I 40,0	1,57	E 38,0	1,50	K 15,2	0,60	L 27,0	1,06	0,45	1,00
	M A13 L15 SCHOTT	Male 801310003						D 87,1	3,43	B 36,0	1,42	H 40,0	1,57	J 24,5	0,96					0,29	0,64
1/2"	F A13 L22 SCHOTT	Female 801310034	12,5	M30x2	G	178,8	7,04	F 102,1	4,02	C 36,0	1,42	I 40,0	1,57	E 38,0	1,50	K 22,2	0,87	L 34,0	1,34	0,49	1,07
	M A13 L22 SCHOTT	Male 801310035						D 94,0	3,70	B 36,0	1,42	H 40,0	1,57	J 24,5	0,96					0,34	0,74
1/2"	F A13 L18 SCHOTT	Female 801310038*	12,5	M26x1.5	G	-	-	F 95,1	3,74	C 36,0	1,42	I 40,0	1,57	E 38,0	1,50	K 18,2	0,72	L 27,0	1,06	0,48	1,05
	M A13 L18 SCHOTT	Male 801310039*						D -	-	B -	-	H -	-	J -	-					-	-
5/8"	F A15 L18 SCHOTT	Female 801310018	16	M26x1.5	G	167,8	6,65	F 97,5	3,84	C 41,0	1,61	I 44,8	1,76	E 42,0	1,65	K 18,2	0,72	L 27,0	1,06	0,62	1,36
	M A15 L18 SCHOTT	Male 801310019						D 87,9	3,46	B 36,0	1,42	H 38,5	1,52	J 27,0	1,06					0,33	0,72
5/8"	F A15 L22 SCHOTT	Female 801310020*	16	M30x2	G	-	-	F -	-	C -	-	I -	-	E -	-	K 22,2	0,87	L 34,0	1,34	-	-
	M A15 L22 SCHOTT	Male 801310021*						D 94,0	3,70	B 36,0	1,42	H 38,5	1,52	J 27,0	1,06					0,35	0,76
3/4"	F A17 L18 SCHOTT	Female 801310022	19	M26x1.5	G	197,7	7,78	F 116,3	4,58	C 46,0	1,81	I 49,8	1,96	E 48,0	1,89	K 18,2	0,72	L 27,0	1,06	0,98	2,16
	M A17 L18 SCHOTT	Male 801310023						D 103,4	4,09	B 46,0	1,81	H 49,8	1,96	J 30,0	1,18					0,54	1,19
3/4"	F A17 L22 SCHOTT	Female 801310024	19	M30x2	G	202,2	7,96	F 120,3	4,74	C 46,0	1,81	I 49,8	1,96	E 48,0	1,89	K 22,2	0,87	L 34,0	1,34	0,97	2,13
	M A17 L22 SCHOTT	Male 801310025						D 103,9	4,29	B 46,0	1,81	H 49,8	1,96	J 30,0	1,18					0,55	1,20
1"	F A21 L22 SCHOTT	Female 801310026*	25	M30x2	G	-	-	F -	-	C -	-	I -	-	E -	-	K 22,2	0,87	L 34,0	1,34	-	-
	M A21 L22 SCHOTT	Male 801310027*						D 120,4	4,74	B 55,0	2,17	H 59,8	2,35	J 36,0	1,42					0,87	1,92
1"	F A21 L28 SCHOTT	Female 801310028*	25	M36x2	G	-	-	F 125,8	4,95	C 55,0	2,17	I 59,8	2,35	E 55,0	2,17	K 28,2	1,11	L 34,0	1,34	1,38	3,04
	M A21 L28 SCHOTT	Male 801310029*						D -	-	B -	-	H -	-	J -	-					-	-

* Available upon request.

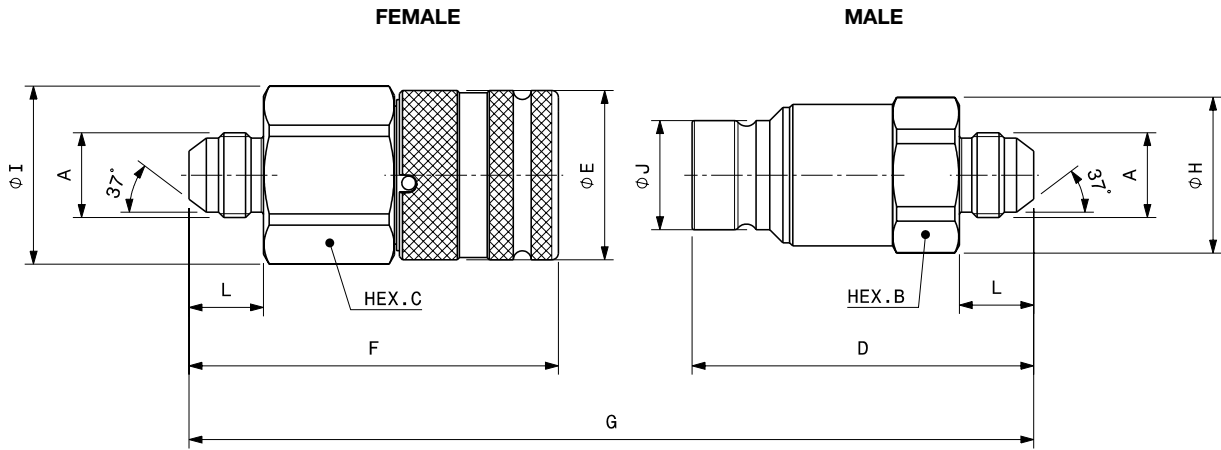

Port description: MALE THREAD JIC - (ISO 8434-2 & SAE J514)

BODY SIZE	Descriptive Code	Item Code	ISO DN	PORT (A)	Overall Length	Length		Hex			Diameter		Diameter		Length		Weight							
						mm	inch	mm	inch	mm	inch	mm	inch	mm	inch	mm	inch	Kg	Lbs					
3/8"	F A9 5/8 JIC	Female 801306000*	10	7/8 -14UNF	G	132,2	5,20	F	75,9	2,99	C	30,0	1,18	I	32,0	1,26	E	32,0	1,26	L	19,3	0,76	0,28	0,61
	M A9 5/8 JIC	Male 801306001*						D	72,3	2,85	B	27,0	1,06	H	29,0	1,14	J	19,7	0,78					
3/8"	F A9 3/8 JIC	Female 801306002*	10	9/16 -18UNF	G	127,1	5,00	F	74,1	2,92	C	30,0	1,18	I	32,0	1,26	E	32,0	1,26	L	14,1	0,56	0,27	0,60
	M A9 3/8 JIC	Male 801306003*						D	69,0	2,72	B	27,0	1,06	H	29,0	1,14	J	19,7	0,78					
3/8"	F A9 1/2 JIC	Female 801306004	10	3/4 -16UNF	G	128,0	5,04	F	74,3	2,93	C	30,0	1,18	I	32,0	1,26	E	32,0	1,26	L	16,7	0,66	0,26	0,57
	M A9 1/2 JIC	Male 801306005						D	69,7	2,74	B	27,0	1,06	H	29,0	1,14	J	19,7	0,78					
1/2"	F A13 7/8 JIC	Female 801306006	12,5	1-3/16-12UN	G	156,0	6,14	F	90,7	3,57	C	36,0	1,42	I	40,0	1,57	E	38,0	1,50	L	22,6	0,89	0,42	0,93
	M A13 7/8 JIC	Male 801306007						D	82,6	3,25	B	36,0	1,42	H	40,0	1,57	J	24,5	0,96					
1/2"	F A13 1 JIC	Female 801306008*	12,5	1-5/16-12UN	G	157,0	6,18	F	91,2	3,59	C	36,0	1,42	I	40,0	1,57	E	38,0	1,50	L	23,1	0,91	0,41	0,91
	M A13 1 JIC	Male 801306009*						D	83,1	3,27	B	36,0	1,42	H	40,0	1,57	J	24,5	0,96					
1/2"	F A13 3/4 JIC	Female 801306012	12,5	1-1/16-12UN	G	154,6	6,09	F	90,0	3,54	C	36,0	1,42	I	40,0	1,57	E	38,0	1,50	L	21,9	0,86	0,41	0,90
	M A13 3/4 JIC	Male 801306013						D	81,9	3,22	B	36,0	1,42	H	40,0	1,57	J	24,5	0,96					
1/2"	F A13 5/8 JIC	Female 801306018*	12,5	7/8 -14UNF	G	-	-	F	-	-	C	-	-	I	-	-	E	-	-	L	19,3	0,76	-	-
	M A13 5/8 JIC	Male 801306019*						D	79,3	3,12	B	36,0	1,42	H	35,0	1,38	J	24,5	0,96					
5/8"	F A15 1 JIC	Female 801306020*	16	1-5/16-12UN	G	150,0	5,91	F	84,5	3,33	C	41,0	1,61	I	44,8	1,76	E	42,0	1,65	L	23,1	0,91	0,54	1,18
	M A15 1 JIC	Male 801306021*						D	83,1	3,27	B	36,0	1,42	H	38,5	1,52	J	27,0	1,06					

* Available upon request.

Zinc Nickel version

A Series is available upon request also in Zinc Nickel version.

The Zinc Nickel plating ensures high resistance to corrosion and it is ideal for hydraulic equipment applications where an improved corrosion resistance is necessary.

For specific codes, configuration or any other information, please contact Stucchi Technical Support.

While maintaining the same interchangeability, the shape differs from the A series in Cr3 due to the addition of the groove for the cap lanyard and in some cases the dimensions may also be different. Request the drawing with overall dimensions.

90° version

A Series is available upon request also in special configuration with 90° fitting.

This version is ideal for applications with less space that requires a compact design and it guarantees the correct bending of the hose.

For specific codes, configuration or any other information, please contact Stucchi Technical Support.

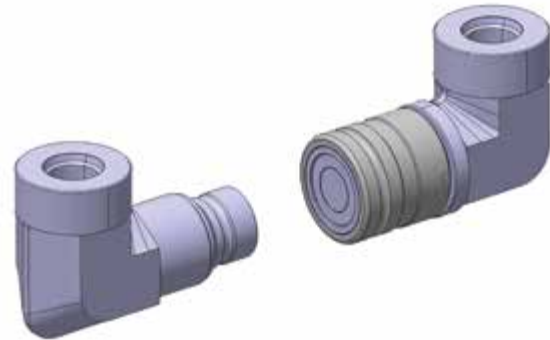
Panel mounting

A Series is available upon request also as panel mounting version.

BC: Snap Ring Solution
Grooves on the male body and on the female sleeve.

BR: Snap Ring Solution
Grooves on the male adaptor and on the female adaptor.

BT: Lock Ring Solution
Thread on the male body and female body.

For specific codes, dimensions or any other information, please contact Stucchi Technical Support.

BC
BR
BT
SS version

For specific cases, A Series is available upon request without the safety lock ball.

For additional information, please contact Stucchi Technical Support.

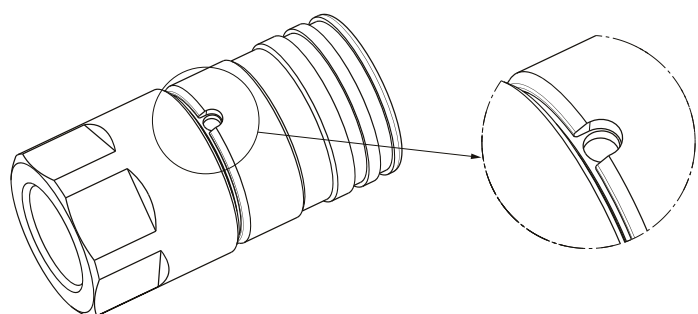



SPARE KIT SEAL FOR MALE

Repair kit / OR+BK		
Body Size	Description	Part Number
1/4"	M A7	815700519
3/8"	M A9	815700337
1/2"	M A13	815700339
5/8"	M A15	815700341
3/4"	M A17	815700343
1"	M A21	815700345
1 1/4"	M A25	815700693
1 1/2"	M A30	815700521

O-Ring in Nitrile
BackUp in Teflon®

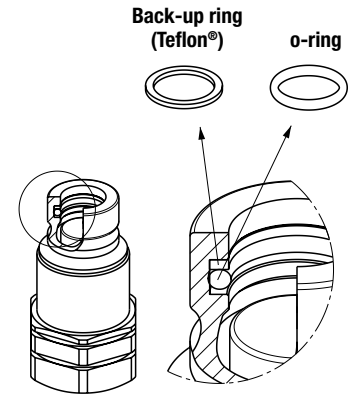

PROTECTIVE CAPS FOR A SERIES

Protective caps are always recommended to protect the couplings from damage, dirt inclusion, and will increase the product life. This is particularly important in mobile applications where exposure to weather and aggregate materials are common.

For the A series are available three kind of materials:

- plastic caps complete with lanyard (standard color: red, other colors available upon request)
- aluminum caps complete with lanyard (standard colors: natural aluminum, other colors available upon request)
- plastic caps, clip system (standard color: red, other colors available upon request)

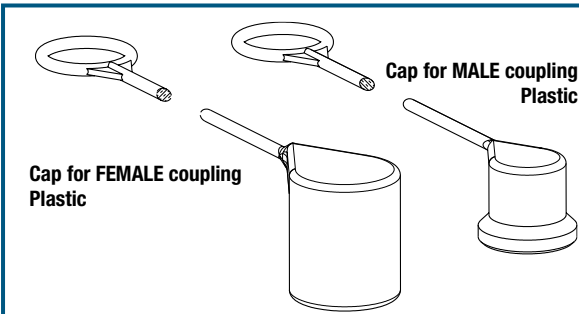

Protective Cap				
Body Size/Description	Part Number		Material/Color	
	Cap for Female	Cap for Male		
1/4" A7	815100000	815100023	Plastic/Red	
3/8" A9	815100002	815100027	Plastic/Red	
1/2" A13	815100006	815100031	Plastic/Red	
5/8" A15	815100008	815100011	Plastic/Red	
3/4" A17	815100010	815100013	Plastic/Red	
1" A21	815100012	815100015	Plastic/Red	

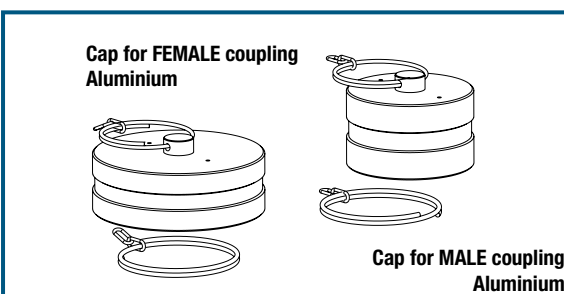

Protective Cap				
Body Size/Description	Part Number		Material/Color	
	Cap for Female	Cap for Male		
1/4" A7	816005002	816005003	Aluminum/Natural	
3/8" A9	816005004	816005005	Aluminum/Natural	
1/2" A13	816005006	816005007	Aluminum/Natural	
3/4" A17	816005010	816005011	Aluminum/Natural	
1" A21	816005012	816005013	Aluminum/Natural	
1 1/4" A25	815205020	815205021	Aluminum/Natural	
1 1/2" A30	815105014	815105017	Aluminum/Natural	

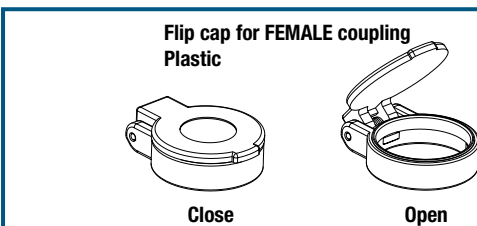

Protective Cap			
Body Size/Description	Part Number		Material/Color
	Cap for Female		
3/8" F A9	815200002		Plastic/Red
1/2" F A13	815200004		Plastic/Red
5/8" F A15	815200006		Plastic/Red
3/4" F A17	815200008		Plastic/Red



APM SERIES

INTERCHANGE > ISO 16028 - NFPA T3.20.15 - HTMA (size 3/8")



Easy CUP



TECHNICAL FEATURES AND OPTIONS

Interchange ISO 16028 NFPA T3.20.15 HTMA (size 3/8")	Sealing description Nitrile NBR	Connection system Push
Available sizes From 3/8" to 1-1/2"	Material/treatment Carbon steel /Cr3	Available threads BSP - NPT - SAE
Operating pressure Up to 350 bar	Locking mechanism Locking ball+ Safety lock (on female coupling)	Flow rate Up to 750 l/min
Temperature (°C) -20° / +100°	Valving style Flat Face	Connection under pressure Connection: Male side only (see Benefits). Disconnection: Not allowed.

BENEFITS

- Easy connection with male side under residual pressure (female side to drain) thanks to the internal valve.
- Flat face is easy to clean, reducing the inclusion of contamination inside the hydraulic circuit.
- Minimal fluid spillage during disconnection, reducing fluid spillage to the environment.
- Minimal air inclusion during connection.
- Internal valve design creates minimal pressure drop, maintaining circuit efficiency in the system.
- Male body black zinc plated for identification
- The modular design allows flexibility with a wide range of configurations.
- Good resistance to pressure impulses.
- Compact slim design.
- Safe and simple to use.

HOW TO USE

- Before to connect, clean the mating surface of the couplings to avoid dirt inclusion in the circuit.
- To connect push the male half towards the female half or vice versa.
- After connection turn the external sleeve to engage safety lock function, to prevent accidental disconnection.
- To disconnect turn the external sleeve until the sleeve lock notch match the safety lock ball and push back the sleeve.

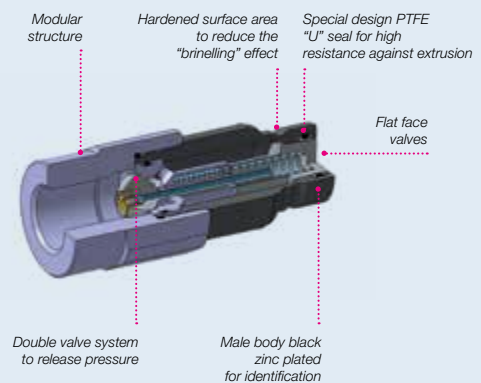
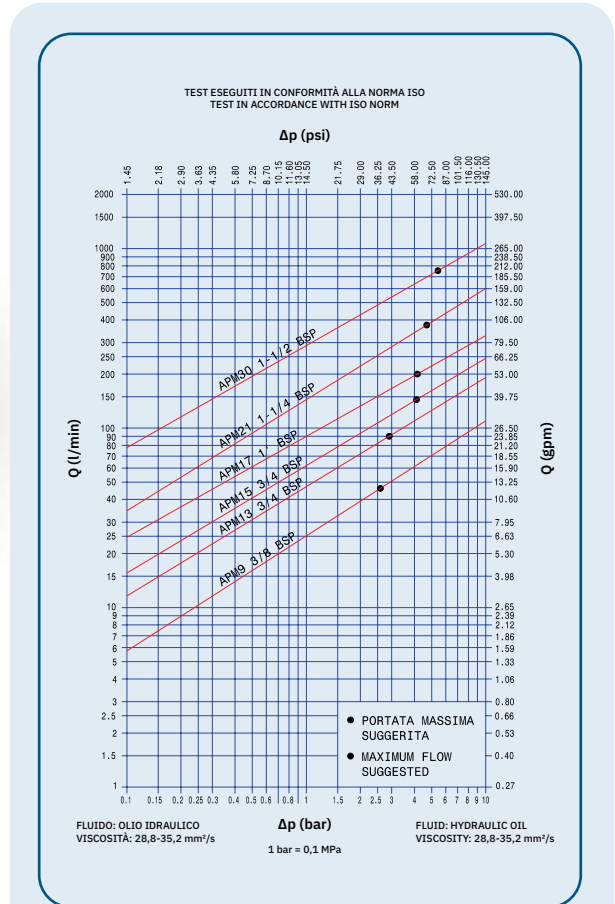

MAIN APPLICATIONS

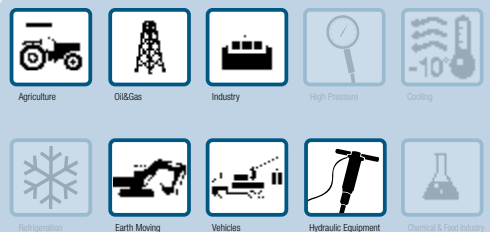

FLAT FACE

PERFORMANCES

Size		Series/Size	Max. flow suggested		Connect force		Disconnect force		Spillage*
Inch	mm (ISO)		l/min	gpm	N	lbf	N	lbf	ml
3/8	10,0	APM9	46	12,19	165	37,13	40	9,00	0,02
1/2	12,5	APM13	90	23,85	190	42,75	70	15,75	0,01
5/8	16,0	APM15	148	39,22	160	36,00	50	11,25	0,03
3/4	19,0	APM17	200	53,00	260	58,50	80	18,00	0,18
1	25,0	APM21	378	100,17	300	67,50	90	20,25	0,18
1 1/2		APM30	750	198,75	440	99,00	80	18,00	0,40

Size	Series/Size	Max. operating pressure				Burst pressure				Max. residual pressure	
		Coupled		Male		Coupled		Male		MPa	psi
		MPa	psi	MPa	psi	MPa	psi	MPa	psi	MPa	psi
3/8	APM9	35	5075	35	5075	100	14500	120	17400	30	4350
1/2	APM13	33	4785	33	4785	100	14500	120	17400	30	4350
5/8	APM15	33	4785	33	4785	100	14500	120	17400	30	4350
3/4	APM17	33	4785	33	4785	100	14500	120	17400	25	3625
1	APM21	30	4350	30	4350	80	11600	100	14500	25	3625
1 1/2	APM30	27	3915	27	3915	80	11600	100	14500	20	2900

* Spillage is an indicative value of the fluid loss during disconnection (according to ISO norm test method).

Theoretical calculation of connect force with residual pressure:

$$F_p (N) = F_i + (P_m \times 5)$$

F_i = Connection force without residual pressure (N)

P_m = Residual pressure in the male coupling (MPa)

EXAMPLE

To connect the male coupling APM13 with 20 Mpa of residual pressure, it is necessary the following force:

$$F_p = F_i + (P_m \times 5) = 190 + (20 \times 5) = 290 \text{ N}$$

Different possible configurations:

Different threads available upon request.

Temperature range:

Seals in NBR (Nitrile): from -20 °C to +100 °C (from -4 °F to +212 °F)

Please read carefully Instructions and warnings for proper selection of the products.

Tests performed:

Tested with female couplings "A" series.

The couplings have been tested at max. operating pressure for 100.000 impulses according to ISO norm test method.



WARNING

A defect, a wrong choice or an improper use of products, can cause injury to persons, animals and objects.

Connect under pressure products are suitable to be connected under residual (static) pressure.

Never connect or disconnect with dynamic pressure (e.g. pump on).

Connection with residual pressure (pressure trapped in the circuit) allowed with female to drain.

Do not use the male coupling disconnected with high impulse pressure.

Do not couple-uncouple with flow in the circuit.

Do not couple-uncouple when the temperature inside of the circuit is higher than 80 °C (176 °F).

Check the maximum allowable working pressure of the port in use.

It is important to limit contamination in the circuit to avoid compromising the function of the internal valves.

Make sure that the medium used is compatible with seal and material as indicated for each series.

In case of doubt please contact Stucchi Technical Support.

The interchangeability is mentioned under the assumption that the manufacturer of the considered products has not changed any dimension.

It is mandatory to carefully read and closely follow the instructions before selecting or using any Stucchi products.

Always refer to the version uploaded in the Instructions and warning section of stucchigroup.com website for the latest release.

For specific, product-related, instructions, please contact Stucchi technical service.

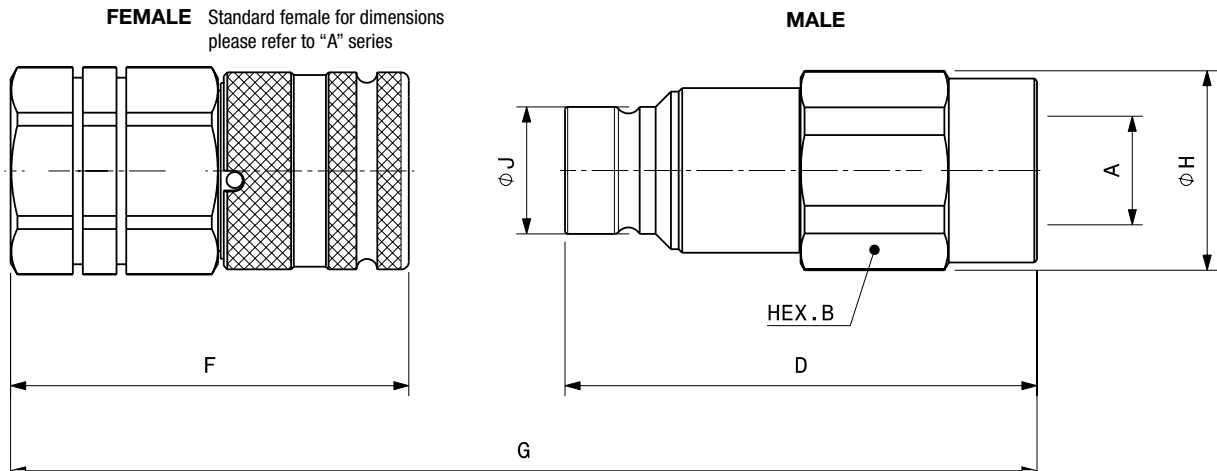
OVERALL DIMENSIONS

Port description: FEMALE THREAD BSPP (ISO 1179-1)

BODY SIZE	Descriptive Code	Item Code	ISO DN	PORT (A)	Overall Length		Length		Hex		Diameter		Diameter		Weight					
					mm	inch	mm	inch	mm	inch	mm	inch	mm	inch	Kg	Lbs				
3/8"	M APM9 3/8 BSP	Male 805200001	10,0	3/8"	G (F+D)-16	(F+D)-0,630	D	80,0	3,15	B	27,0	1,06	H	29,0	1,14	J	19,7	0,78	0,20	0,43
3/8"	M APM9 1/2 BSP	Male 805200003	10,0	1/2"	G (F+D)-16	(F+D)-0,630	D	82,5	3,25	B	27,0	1,06	H	29,0	1,14	J	19,7	0,78	0,20	0,43
1/2"	M APM13 1/2 BSP	Male 805200005	12,5	1/2"	G (F+D)-17,3	(F+D)-0,681	D	91,0	3,58	B	36,0	1,42	H	38,5	1,52	J	24,5	0,96	0,41	0,90
1/2"	M APM13 3/4 BSP	Male 805200007	12,5	3/4"	G (F+D)-17,3	(F+D)-0,681	D	93,5	3,68	B	36,0	1,42	H	38,5	1,52	J	24,5	0,96	0,40	0,89
5/8"	M APM15 3/4 BSP	Male 805200009	16,0	3/4"	G (F+D)-17,6	(F+D)-0,693	D	95,0	3,74	B	36,0	1,42	H	38,5	1,52	J	27,0	1,06	0,43	0,94
3/4"	M APM17 1 BSP	Male 805200011	19,0	1"	G (F+D)-22	(F+D)-0,866	D	108,5	4,27	B	46,0	1,81	H	49,8	1,96	J	30,0	1,18	0,75	1,65
1"	M APM21 1-1/4 BSP	Male 805200017	25,0	1 1/4"	G (F+D)-23	(F+D)-0,906	D	123,5	4,86	B	55,0	2,17	H	59,8	2,35	J	36,0	1,42	1,16	2,56
1-1/2"	M APM30 1-1/2 BSP	Male 805200015	-	1 1/2"	G (F+D)-28,6	(F+D)-1,126	D	146,9	5,78	B	70,0	2,76	H	75,8	2,98	J	57,0	2,24	2,58	5,69

Port description: FEMALE THREAD NPT (ANSI B.1.20.1)

BODY SIZE	Descriptive Code	Item Code	ISO DN	PORT (A)	Overall Length		Length		Hex		Diameter		Diameter		Weight					
					mm	inch	mm	inch	mm	inch	mm	inch	mm	inch	Kg	Lbs				
3/8"	M APM9 3/8 NPT	Male 805201001	10,0	3/8"	G (F+D)-16	(F+D)-0,630	D	80,0	3,15	B	27,0	1,06	H	29,0	1,14	J	19,7	0,78	0,21	0,46
3/8"	M APM9 1/2 NPT	Male 805201003	10,0	1/2"	G (F+D)-16	(F+D)-0,630	D	82,5	3,25	B	27,0	1,06	H	29,0	1,14	J	19,7	0,78	0,21	0,45
1/2"	M APM13 1/2 NPT	Male 805201005	12,5	1/2"	G (F+D)-17,3	(F+D)-0,681	D	91,0	3,58	B	36,0	1,42	H	38,5	1,52	J	24,5	0,96	0,43	0,95
1/2"	M APM13 3/4 NPT	Male 805201007	12,5	3/4"	G (F+D)-17,3	(F+D)-0,681	D	93,5	3,68	B	36,0	1,42	H	38,5	1,52	J	24,5	0,96	0,42	0,91
5/8"	M APM15 3/4 NPT	Male 805201009	16,0	3/4"	G (F+D)-17,6	(F+D)-0,693	D	95,0	3,74	B	36,0	1,42	H	38,5	1,52	J	27,0	1,06	0,44	0,96
3/4"	M APM17 1 NPT	Male 805201011	19,0	1"	G (F+D)-22	(F+D)-0,866	D	108,5	4,27	B	46,0	1,81	H	49,8	1,96	J	30,0	1,18	0,76	1,68
1"	M APM21 1-1/4 NPT	Male 805201017	25,0	1 1/4"	G (F+D)-23	(F+D)-0,906	D	123,5	4,86	B	55,0	2,17	H	59,8	2,35	J	36,0	1,42	1,20	2,65
1-1/2"	M APM30 1-1/2 NPT	Male 805201015	-	1 1/2"	G (F+D)-28,6	(F+D)-1,126	D	146,9	5,78	B	70,0	2,76	H	75,8	2,98	J	57,0	2,24	2,60	5,72

Port description: FEMALE THREAD SAE (ISO 11926-1 & SAE J1926-1)

BODY SIZE	Descriptive Code	Item Code	ISO DN	PORT (A)	Overall Length		Length		Hex		Diameter		Diameter		Weight					
					mm	inch	mm	inch	mm	inch	mm	inch	mm	inch	Kg	Lbs				
3/8"	M APM9 1/2 SAE	Male 805204001	10,0	3/4-16UNF	G (F+D)-16	(F+D)-0,630	D	82,5	3,25	B	27,0	1,06	H	29,0	1,14	J	19,7	0,78	0,21	0,45
1/2"	M APM13 5/8 SAE	Male 805204003	12,5	7/8-14UNF	G (F+D)-17,3	(F+D)-0,681	D	91,0	3,58	B	36,0	1,42	H	38,5	1,52	J	24,5	0,96	0,41	0,91
1/2"	M APM13 3/4 SAE	Male 805204005	12,5	1-1/16-12UN	G (F+D)-17,3	(F+D)-0,681	D	93,5	3,68	B	36,0	1,42	H	38,5	1,52	J	24,5	0,96	0,40	0,88
5/8"	M APM15 3/4 SAE	Male 805204007	16,0	1-1/16-12UN	G (F+D)-17,6	(F+D)-0,693	D	95,0	3,74	B	36,0	1,42	H	38,5	1,52	J	27,0	1,06	0,43	0,94
3/4"	M APM17 1 SAE	Male 805204009	19,0	1-5/16-12UN	G (F+D)-22	(F+D)-0,866	D	108,5	4,27	B	46,0	1,81	H	49,8	1,96	J	30,0	1,18	0,76	1,66
1"	M APM21 1-1/4 SAE	Male 805204017	25,0	1-5/8-12UN	G (F+D)-23	(F+D)-0,906	D	123,5	4,86	B	55,0	2,17	H	59,8	2,35	J	36,0	1,42	1,19	2,61
1-1/2"	M APM30 1-1/2 SAE	Male 805204015	-	1-7/8-12UN	G (F+D)-28,6	(F+D)-1,126	D	146,9	5,78	B	70,0	2,76	H	75,8	2,98	J	57,0	2,24	2,56	5,64

To calculate G see measure F in the leaflet A series



SPARE KIT SEAL FOR MALE

Repair kit / OR+BK		
Body Size	Description	Part Number
3/8"	M APM9	815700337
1/2"	M APM13	815700339
5/8"	M APM15	815700341
3/4"	M APM17	815700655
1"	M APM21	815700345
1 1/2"	M APM30	815700697*

* OR + O-Ring holder

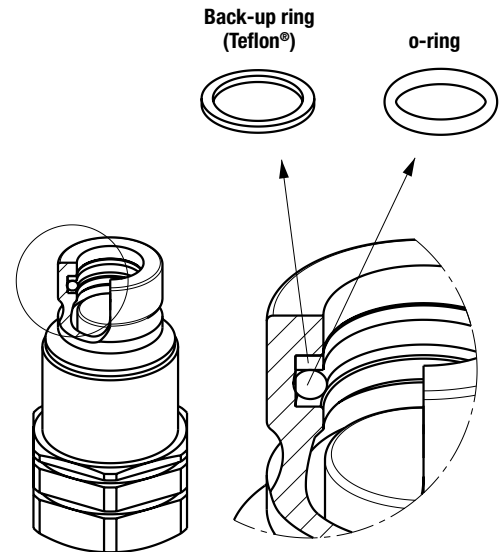

O-Ring in NBR
BackUp in PTFE

PROTECTIVE CAPS FOR APM SERIES

Protective caps are always recommended to protect the couplings from damage, dirt inclusion, and will increase the product life. This is particularly important in mobile applications where exposure to weather and aggregate materials are common.

The protection caps for APM couplings are manufactured in plastic with connection lanyard (standard color red, other colors available upon request).

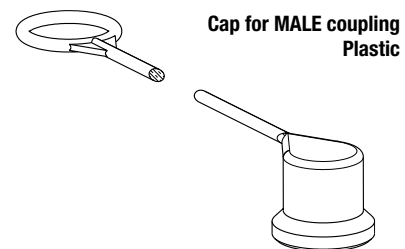

Body Size/Description		Protective Cap	
		Part Number	Material/Color
		Cap for Male	
3/8"	M APM9	815100025	Plastic/Red
1/2"	M APM9	815100027	Plastic/Red
1/2"	M APM13	815100029	Plastic/Red
3/4"	M APM13	815100031	Plastic/Red
3/4"	M APM15	815100011	Plastic/Red
1"	M APM17	815100013	Plastic/Red
1-1/4"	M APM21	815100015	Plastic/Red
1-1/2"	M APM30	815100017	Aluminum/Red



A-HD SERIES

INTERCHANGE > ISO 16028 - NFPA T3.20.15 - HTMA (size 3/8")















Stucchi®

FLAT FACE



TECHNICAL FEATURES AND OPTIONS

 Interchange ISO 16028 NFPA T3.20.15 HTMA (size 3/8")	 Sealing description Nitrile NBR	 Connection system Push
 Available sizes from 3/8" to 1/2"	 Material/treatment Carbon steel /Cr3	 Available threads BSP - NPT - SAE
 Operating pressure Up to 350 bar	 Locking mechanism Locking ball + Safety Lock	 Flow rate Up to 90 l/min
 Temperature (°C) -20° / +100°	 Valving style Flat face	 Connection under pressure Connection: Female side only (see Benefits). Disconnection: Not allowed.

BENEFITS

- Easy connection with female side under residual pressure (male side to drain) thanks to the special Stucchi design.
- Flat face is easy to clean, reducing the inclusion of contamination inside the hydraulic circuit.
- Minimal fluid spillage during disconnection, reducing fluid spillage to the environment.
- Minimal air inclusion during connection.
- Internal valve design creates minimal pressure drop and maintaining circuit efficiency in the system
- The modular design allows flexibility with a wide range of configurations.
- Good resistance to pressure impulses.
- Galvanized black body for easy identification
- Compact slim design.
- Safe and simple to use.

HOW TO USE

- Before to connect, clean the mating surface of the couplings to avoid dirt inclusion in the circuit.
- To connect push the male half towards the female half or vice versa.
- After connection turn the external sleeve to engage safety lock function, to prevent accidental disconnection.
- To disconnect turn the external sleeve until the sleeve lock notch match the safety lock ball and push back the sleeve.

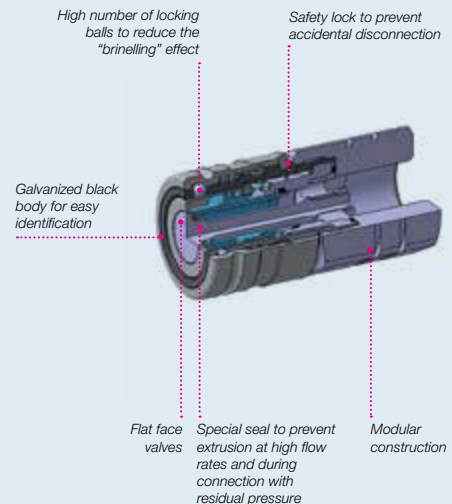
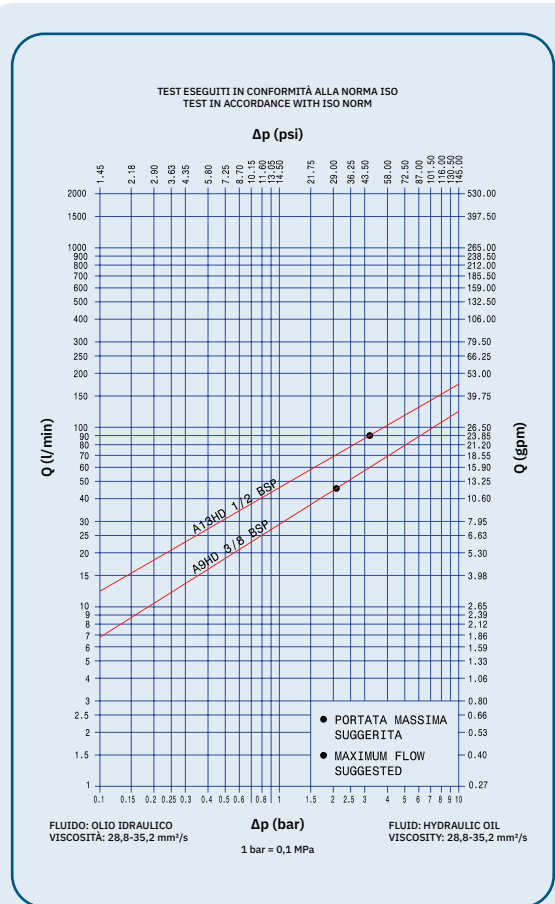

MAIN APPLICATIONS



PERFORMANCES

Size		Series/Size	Max. flow suggested		Connect force		Disconnect force		Spillage*
Inch	mm (ISO)		l/min	gpm	N	lbf	N	lbf	ml
3/8	10	F -A9HD	46	12,19	190	42,75	30	6,75	0,01
1/2	12,5	F- A13HD	90	23,85	170	38,25	55	12,37	0,02

Size	Series/Size	Max. operating pressure				Burst pressure			
		Coupled		Female		Coupled		Female	
Inch		MPa	psi	MPa	psi	MPa	psi	MPa	psi
3/8	F- A9HD	35	5075	35	5075	100	14500	100	14500
1/2	F- A13HD	33	4785	33	4785	100	14500	100	14500

* Spillage is an indicative value of the fluid loss during disconnection (according to ISO norm test method).

Theoretical calculation of connect force with residual pressure:

$$F_p (N) \text{ size } 3/8" = F_i + (P_f \times 44)$$

$$F_p (N) \text{ size } 1/2" = F_i + (P_f \times 66)$$

F_p = Connection force with residual pressure (N)

F_i = Connection force without residual pressure (N)

P_f = Residual pressure in the female coupling (MPa)

EXAMPLE

To connect the female coupling A9HD with 5 Mpa of residual pressure, the following force is necessary:

$$F_p = F_i + (P_f \times 44) = 190 + (5 \times 44) = 410 \text{ N}$$

This is the maximum force required to open the female valve in order to release pressure.

It is not necessary to apply this force during the entire connection but just for a short stroke (about 1mm).

Different possible configurations:

Different threads available upon request.

Temperature range:

Standard seals in NBR, PUR, POM: from -20 °C to +100 °C (from -4 °F to +212 °F).

Please read carefully Instructions and warnings for proper selection of the products.

Tests performed:

Tested with male couplings "A" series

The couplings have been tested at max. operating pressure for 1.000.000 impulses in connected position according to ISO norm test method.



WARNING

A defect, a wrong choice or an improper use of products, can cause injury to persons, animals and objects.

Connect under pressure products are suitable to be connected under residual (static) pressure.

Never connect or disconnect with dynamic pressure (e.g. pump on).

Connection with residual pressure (pressure trapped in the circuit) allowed with male to drain (please check the hydraulic circuit).

Do not use the female coupling disconnected with high impulse pressure.

Do not couple-uncouple with flow in the circuit.

Do not couple-uncouple when the temperature inside of the circuit is higher than 80 °C (176 °F).

Check the maximum allowable working pressure of the port in use.

Make sure that the medium used is compatible with seal and material as indicated for each series.

In case of doubt please contact Stucchi Technical Support.

The interchangeability is mentioned under the assumption that the manufacturer of the considered products has not changed any dimension.

It is mandatory to carefully read and closely follow the instructions before selecting or using any Stucchi products.

Always refer to the version uploaded in the Instructions and warning section of stucchigroup.com website for the latest release.

For specific, product-related, instructions, please contact Stucchi technical service.

OVERALL DIMENSIONS

FLAT FACE

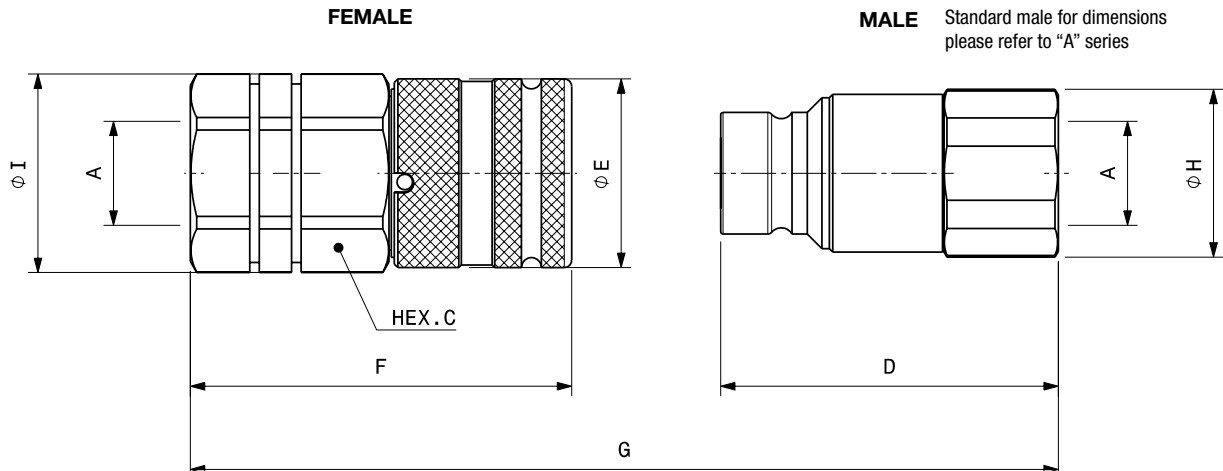

Port description: FEMALE THREAD BSPP (ISO 1179-1)

BODY SIZE	Descriptive Code	Item Code	ISO DN	PORT (A)	Overall Length		Length		Hex		Diameter		Diameter		Weight						
					mm	inch	mm	inch	mm	inch	mm	inch	mm	inch	Kg	Lbs					
3/8"	F A9HD 3/8 BSP	Female 808300004	10,0	3/8"	G	(F+D)-16	(F+D)-0,630	F	64,8	2,55	C	30,0	1,18	I	32,0	1,26	E	32,0	1,26	0,28	0,62
3/8"	F A9HD 1/2 BSP	Female 808300006	10,0	1/2"	G	(F+D)-16	(F+D)-0,630	F	69,8	2,75	C	30,0	1,18	I	32,0	1,26	E	32,0	1,26	0,29	0,64
1/2"	F A13HD 1/2 BSP	Female 808300008	12,5	1/2"	G	(F+D)-17,3	(F+D)-0,681	F	76,8	3,02	C	36,0	1,42	I	40,0	1,57	E	38,0	1,50	0,47	1,03
1/2"	F A13HD 3/4 BSP	Female 808300010	12,5	3/4"	G	(F+D)-17,3	(F+D)-0,681	F	83,8	3,30	C	36,0	1,42	I	40,0	1,57	E	38,0	1,50	0,48	1,06

Port description: FEMALE THREAD NPT (ANSI B.1.20.1)

BODY SIZE	Descriptive Code	Item Code	ISO DN	PORT (A)	Overall Length		Length		Hex		Diameter		Diameter		Weight						
					mm	inch	mm	inch	mm	inch	mm	inch	mm	inch	Kg	Lbs					
1/2"	F A13HD 1/2 NPT	Female 808301008	12,5	1/2"	G	(F+D)-16	(F+D)-0,630	F	76,8	3,02	C	36,0	1,42	I	40,0	1,57	E	38,0	1,50	0,47	1,04
1/2"	F A13HD 3/4 NPT	Female 808301010	12,5	3/4"	G	(F+D)-16	(F+D)-0,630	F	83,8	3,30	C	36,0	1,42	I	40,0	1,57	E	38,0	1,50	0,49	1,07

Port description: FEMALE THREAD SAE (ISO 11926-1 & SAE J1926-1)

BODY SIZE	Descriptive Code	Item Code	ISO DN	PORT (A)	Overall Length		Length		Hex		Diameter		Diameter		Weight						
					mm	inch	mm	inch	mm	inch	mm	inch	mm	inch	Kg	Lbs					
3/8"	F A9HD 1/2 SAE	Female 808304008*	10,0	3/4-16 UNF	G	(F+D)-16	(F+D)-0,630	F	69,8	2,75	C	30,0	1,18	I	32,0	1,26	E	32,0	1,26	0,30	0,66
3/8"	F A9HD 5/8 SAE	Female 808304010*	10,0	7/8-14UNF	G	(F+D)-17,3	(F+D)-0,681	F	71,8	2,83	C	30,0	1,18	I	32,0	1,26	E	32,0	1,26	0,29	0,64
1/2"	F A13HD 1/2 SAE	Female 808304016	12,5	3/4-16UNF	G	(F+D)-17,3	(F+D)-0,681	F	76,8	3,02	C	36,0	1,42	I	40,0	1,57	E	38,0	1,50	0,48	1,05
1/2"	F A13HD 5/8 SAE	Female 808304012	12,5	7/8-14UNF	G	(F+D)-17,6	(F+D)-0,693	F	78,8	3,10	C	36,0	1,42	I	40,0	1,57	E	38,0	1,50	0,47	1,04
1/2"	F A13HD 3/4 SAE	Female 808304014	12,5	1-1/16-12UNF	G	(F+D)-22	(F+D)-0,866	F	83,8	3,30	C	36,0	1,42	I	40,0	1,57	E	38,0	1,50	0,47	1,03

* Available upon request.

Also possible with following male threads:

- SAE
- JIC
- JIC Bulkhead

Please check availability by contacting your Stucchi contact

To calculate G see measure D in the leaflet A series

Panel mounting

A-HD Series is available upon request also as panel mounting version.

BC: Snap Ring Solution
Grooves on the female sleeve.

BR: Snap Ring Solution
Grooves on the female adaptor.

BT: Lock Ring Solution
Thread on the female body.

For specific codes, dimensions or any other information, please contact Stucchi Technical Support.

SS version

For specific cases, A-HD Series is available upon request without the safety lock ball.

For additional information, please contact Stucchi Technical Support.

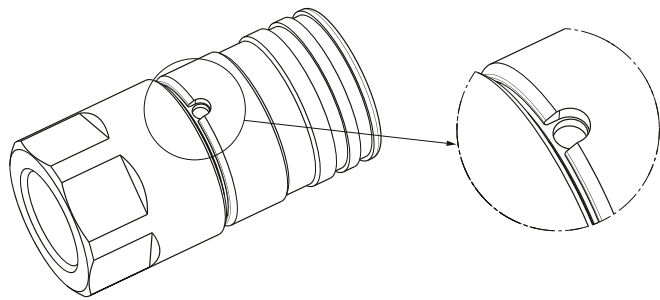
PROTECTIVE CAPS FOR A-HD SERIES

Protective caps are always recommended to protect the couplings from damage, dirt inclusion, and will increase the product life. This is particularly important in mobile applications where exposure to weather and aggregate materials are common.

The protective caps for A-HD couplings are manufactured in two versions:

- Plastic with connection lanyard (standard color red, other colors available upon request).
- Plastic flip caps version (standard color red, other colors available upon request).

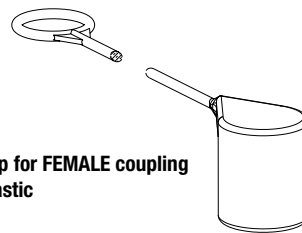

**Cap for FEMALE coupling
Plastic**

Protective Cap		
Body Size/Description	Part Number	Material/Color
3/8" F A9HD	815100002	Plastic/Red
1/2" F A13HD	815100004	Plastic/Red

**Flip cap for FEMALE coupling
Plastic**

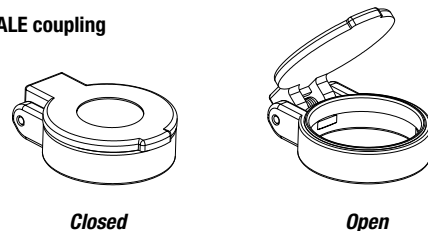

Protective Cap		
Body Size/Description	Part Number	Material/Color
3/8" A9HD	815200002	Plastic/Red
1/2" A13HD	815200004	Plastic/Red

STUCCHI Quick Couplings Catalog - April 2021 - All right reserved.

Texts, data and illustrations mentioned in this catalogue may be changed by Stucchi at any time, without notice; always refer to the version uploaded on the English version of stucchi.com/en website for the latest release. In case of doubt, please contact Stucchi technical service.



AXSERIES

INTERCHANGE > ISO 16028 - NFPA T3.20.15 - HTMA (size 3/8")



Stucchi®

FLAT FACE



TECHNICAL FEATURES AND OPTIONS

Interchange ISO 16028 NFPA T3.20.15 HTMA (size 3/8")	Sealing description FKM (VITON®)	Connection system Push
Available sizes from 3/8" to 1"	Material Stainless steel (AISI 316L)	Available threads BSP - METRIC
Operating pressure Up to 350 bar	Locking mechanism Locking ball + Safety Lock	Flow rate Up to 378 l/min
Temperature (°C) -15° / +180°	Valving style Flat face	Connection under pressure Connection: not allowed Disconnection: not allowed

BENEFITS

- Flat face is easy to clean, reducing the inclusion of contamination inside the hydraulic circuit.
- Minimal fluid spillage during disconnection, reducing fluid spillage to the environment.
- Minimal air inclusion during connection.
- Internal valve design creates minimal pressure drop, maintaining circuit efficiency in the system.
- The modular design allows flexibility with a wide range of configurations.
- Optimal corrosion resistance.
- Compact slim design.
- Safe and simple to use.

HOW TO USE

- Before to connect, clean the mating surface of the couplings to avoid dirt inclusion in the circuit.
- To connect push the male half towards the female half or vice versa.
- After connection turn the external sleeve to engage safety lock function, to prevent accidental disconnection.
- To disconnect turn the external sleeve until the sleeve lock notch match the safety lock ball and push back the sleeve.

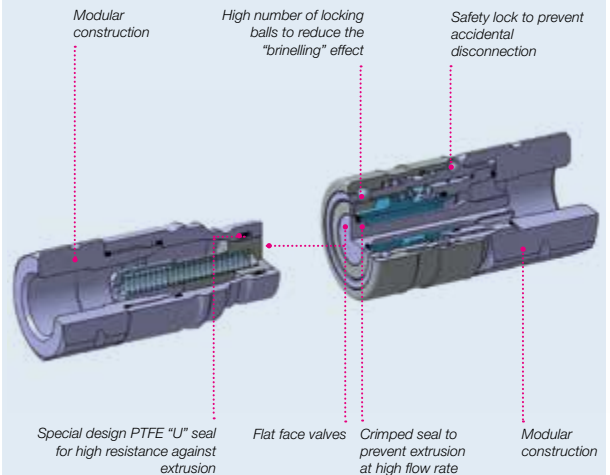
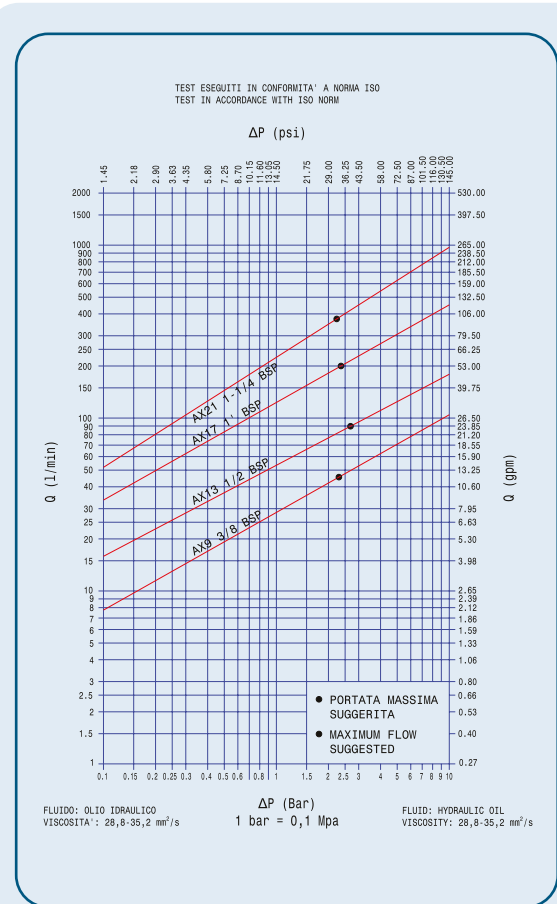

MAIN APPLICATIONS



PERFORMANCES

Size		Series/Size	Max. flow suggested		Connect force		Disconnect force		Spillage*
Inch	mm (ISO)		l/min	gpm	N	lbf	N	lbf	ml
3/8	10	AX9	46	12,19	200	45	45	10,12	0,01
1/2	12,5	AX13	90	23,85	165	37,12	58	13,05	0,02
3/4	19	AX17	200	53	255	57,37	80	18	0,03
1	25	AX21	378	100,17	285	64,12	110	24,75	0,03

Size	Series/Size	Max. operating pressure					
		Coupled		Male		Female	
Inch		MPa	psi	MPa	psi	MPa	psi
3/8	AX9	35	5075	35	5075	35	5075
1/2	AX13	33	4785	33	4785	33	4785
3/4	AX17	33	4785	33	4785	33	4785
1	AX21	30	4350	30	4350	30	4350

* Spillage is an indicative value of the fluid loss during disconnection (according to ISO norm test method).

Temperature range:

Seals in VITON® : from -15°C to +180°C (from +5 °F to +356 °F).
Different seals available upon request.

Material:

- Construction: Stainless steel AISI 316L
- Springs: AISI 302
- Locking ball: AISI 316

Different possible configurations:

Size AX7 and AX15 upon request.
Different threads available upon request.

WARNING

A defect, a wrong choice or an improper use of products, can cause injury to persons, animals and objects.

Never connect or disconnect with dynamic pressure (e.g. pump on).

Do not use the female coupling disconnected with high impulse pressure.

Do not couple-uncouple with flow and/or pressure in the circuit.

Do not couple-uncouple when the temperature inside of the circuit is higher than 80 °C (176 °F).

Check the maximum allowable working pressure of the port in use.

Make sure that the medium used is compatible with seal and material as indicated for each series.

In case of doubt please contact Stucchi Technical Support.

The interchangeability is mentioned under the assumption that the manufacturer of the considered products has not changed any dimension.

It is mandatory to carefully read and closely follow the instructions before selecting or using any Stucchi products.

Always refer to the version uploaded in the Instructions and warning section of stucchigroup.com website for the latest release.

For specific, product-related, instructions, please contact Stucchi technical service.

OVERALL DIMENSIONS

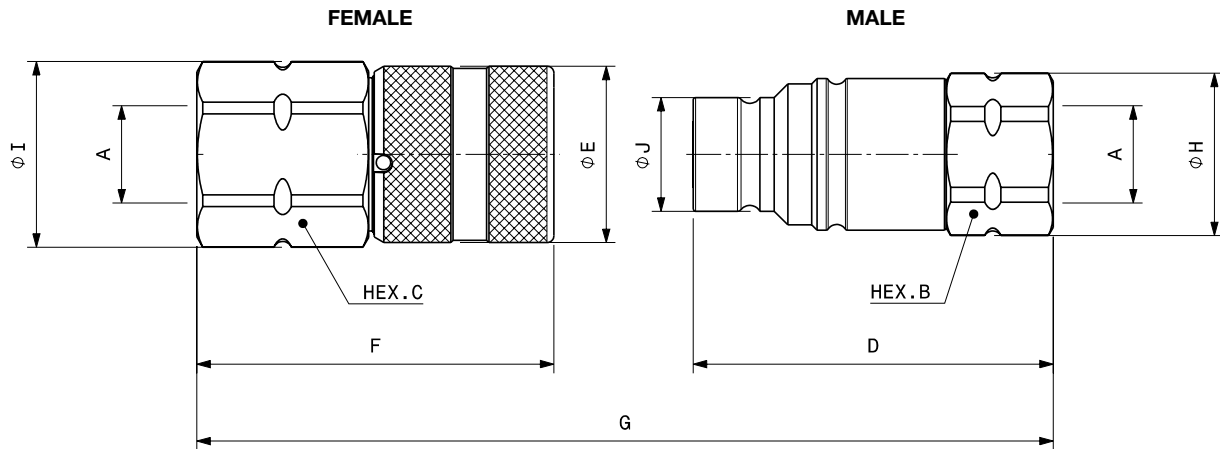

FLAT FACE

Port description: FEMALE THREAD SAE (SAE J1926-1 or ISO 11926-1)

BODY SIZE	Descriptive Code	Item Code	ISO DN	PORT (A)	Overall Length		Length		Hex		Diameter		Diameter		Weight						
					mm	inch	mm	inch	mm	inch	mm	inch	mm	inch	Kg	Lbs					
3/8"	F AX9 3/8 SAE	Female 808504104 *	10	9/16-18UNF	G	118,8	4,68	F	69,4	2,73	C	30,0	1,18	I	32,0	1,26	E	32,0	1,26	0,30	0,66
	M AX9 3/8 SAE	Male 808504105 *						D	65,4	2,57	B	27,0	1,06	H	29,0	1,14	J	19,7	0,78	0,16	0,34
3/8"	F AX9 1/2 SAE	Female 808504106	10	3/4-16UNF	G	125,8	4,95	F	74,4	2,93	C	30,0	1,18	I	32,0	1,26	E	32,0	1,26	0,33	0,72
	M AX9 1/2 SAE	Male 808504107						D	67,4	2,65	B	27,0	1,06	H	29,0	1,14	J	19,7	0,78	0,16	0,35
3/4"	F AX17 3/4 SAE	Female 808504114	18	1-1/16-12UN	G	167,3	6,59	F	103,8	4,09	C	46,0	1,81	I	49,8	1,96	E	48,0	1,89	1,08	2,37
	M AX17 3/4 SAE	Male 808504115						D	85,7	3,37	B	46,0	1,81	H	49,5	1,95	J	30,0	1,18	0,54	1,18
3/4"	F AX17 1" SAE	Female 808504120 *	19	1-5/16-12UN	G	170,3	6,70	F	103,8	4,09	C	46,0	1,81	I	49,8	1,96	E	48,0	1,89	-	-
	M AX17 1" SAE	Male 808504121 *						D	88,7	3,49	B	46,0	1,81	H	49,5	1,95	J	30,0	1,18	-	-
1"	F AX21 1 1/4 SAE	Female 808504122 *	25	1-5/8-12UN	G	185,8	7,31	F	108,3	4,26	C	55,0	2,17	I	59,8	2,35	E	55,0	2,17	1,42	3,13
	M AX21 1 1/4 SAE	Male 808504123 *						D	100,2	3,94	B	55,0	2,17	H	59,8	2,35	J	36,0	1,42	0,82	1,80

* Available upon request.

Port description: FEMALE THREAD BSPP (ISO 1179-1)

BODY SIZE	Descriptive Code	Item Code	ISO DN	PORT (A)	Overall Length		Length		Hex		Diameter		Diameter		Weight						
					mm	inch	mm	inch	mm	inch	mm	inch	mm	inch	Kg	Lbs					
3/8"	F AX9 3/8 BSP	Female 808500104	10	3/8"	G	118,8	4,67	F	69,4	2,73	C	30,0	1,18	I	32,0	1,26	E	32,0	1,26	0,30	0,66
	M AX9 3/8 BSP	Male 808500105						D	65,4	2,57	B	27,0	1,06	H	29,0	1,14	J	19,7	0,78	0,16	0,34
1/2"	F AX13 1/2 BSP	Female 808500108	12,5	1/2"	G	137,1	5,40	F	76,9	3,03	C	36,0	1,42	I	40,0	1,57	E	38,0	1,50	0,48	1,05
	M AX13 1/2 BSP	Male 808500109						D	77,5	3,05	B	32,0	1,26	H	35,0	1,38	J	24,5	0,96	0,30	0,66
3/4"	F AX17 3/4 BSP	Female 808500114	19	3/4"	G	167,5	6,59	F	103,8	4,09	C	46,0	1,81	I	49,8	1,96	E	48,0	1,89	1,06	2,33
	M AX17 3/4 BSP	Male 808500115						D	85,7	3,37	B	46,0	1,81	H	49,5	1,95	J	30,0	1,18	0,53	1,16



SPARE KIT SEAL FOR MALE

Repair kit / OR+BK		
Body Size	Description	Part Number
3/8"	M AX9	815700247
1/2"	M AX13	815700249
3/4"	M AX17	815700253
1"	M AX21	815700255

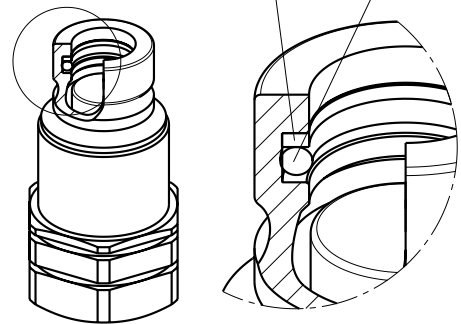
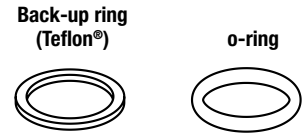

O-Ring in VITON®
BackUp in Teflon®

PROTECTIVE CAPS FOR AX SERIES

Protective caps are always recommended to protect the couplings from damage, dirt inclusion, and will increase the product life. This is particularly important in mobile applications where exposure to weather and aggregate materials are common.

The protective caps for AX couplings are manufactured in aluminum with lanyard (colors: natural aluminum).

Cap for FEMALE coupling
Aluminum

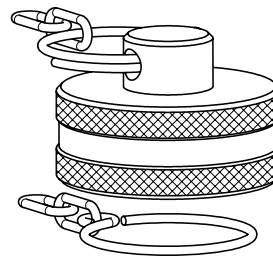

Cap for MALE coupling
Aluminum

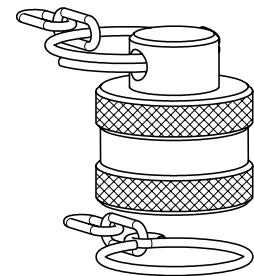

Body Size/Description	Protective Cap		Material/Color
	Part Number	Part Number	
	Cap for Female	Cap for Male	
3/8" AX9	816005004	816005005	Aluminum/Natural
1/2" AX13	816005006	816005007	Aluminum/Natural
3/4" AX17	816005010	816005011	Aluminum/Natural
1" AX21	816005012	816005013	Aluminum/Natural

The protective caps for AX couplings are also available in plastic (see A series caps at page 37).

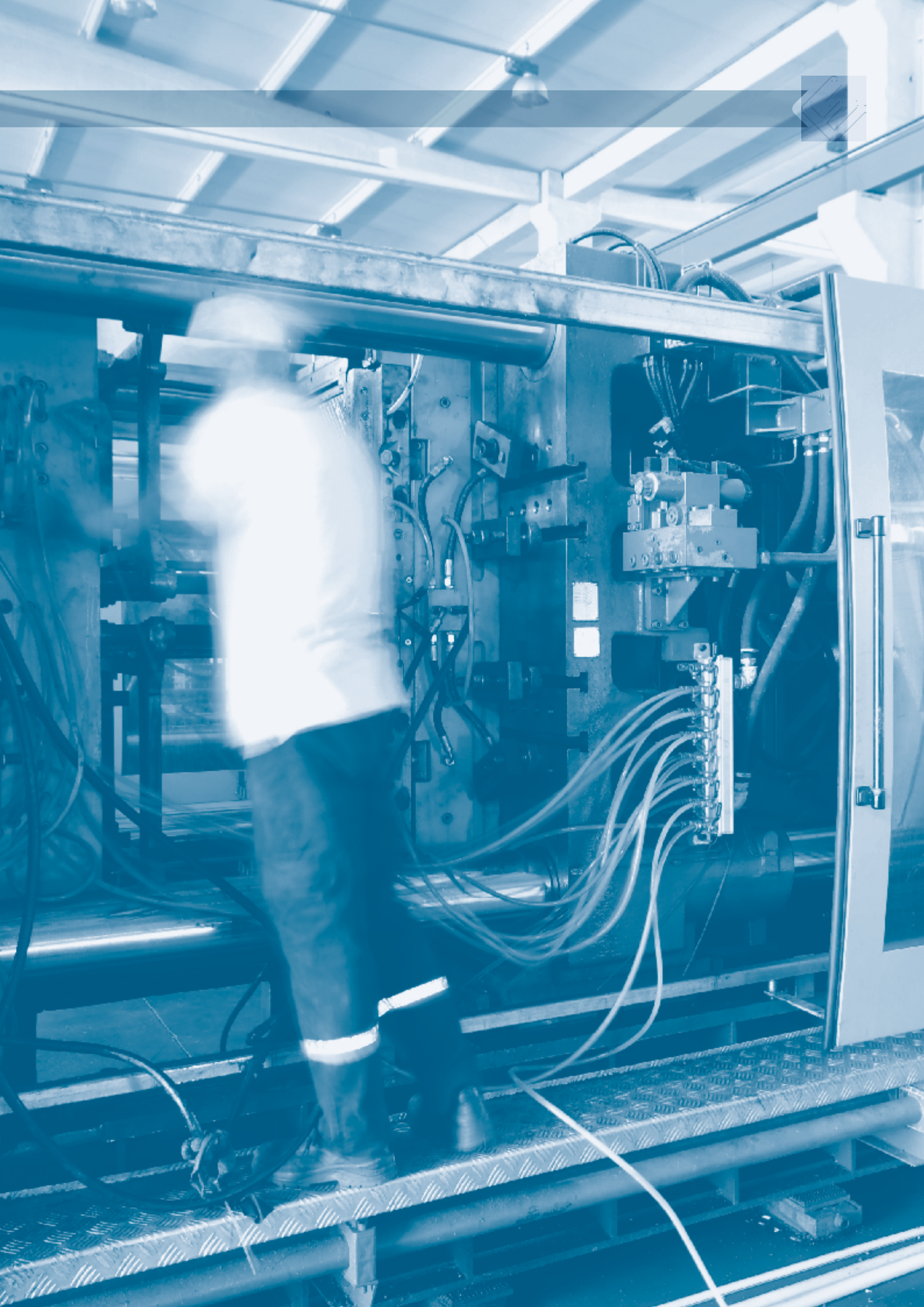

FIRG-QSERIES

INTERCHANGE > ISO 16028 - NFPA T3.20.15 - HTMA (size 3/8")



Stucchi®

FLAT FACE



TECHNICAL FEATURES AND OPTIONS

Interchange ISO 16028 NFPA T3.20.15 HTMA (size 3/8")	Sealing description Nitrile NBR-FKM (VITON®)-EPDM-KALREZ®	Connection system Push
Available sizes from 1/4" to 2"	Material/treatment Carbon steel+Stainless steel (AISI 316L) / QPQ	Available threads BSP - NPT
Operating pressure Up to 300 bar	Locking mechanism Locking ball + Safety Lock	Flow rate Up to 1000 l/min
Temperature (°C) different seals with a range of -40°/+300°	Valving style Flat face	Connection under pressure Connection: not allowed Disconnection: not allowed

BENEFITS

- Flat face is easy to clean, reducing the inclusion of contamination inside the hydraulic circuit.
- Minimal fluid spillage during disconnection, reducing fluid spillage to the environment.
- Minimal air inclusion during connection.
- Superior corrosion resistance compared to zinc plating in specific corrosive environments.
- External parts in carbon steel with QPQ, valving in AISI303.
- Good resistance to pressure impulses.
- Compact slim design.
- Safe and simple to use.

HOW TO USE

- Before to connect, clean the mating surface of the couplings to avoid dirt inclusion in the circuit.
- To connect push the male half towards the female half or vice versa.
- After connection turn the external sleeve to engage safety lock function, to prevent accidental disconnection.
- To disconnect turn the external sleeve until the sleeve lock notch match the safety lock ball and push back the sleeve.
- Provide an adequate maintenance of the parts (washing with clear water, lubricating and greasing the QPQ surface) to prolongue the life in corrosive environment.

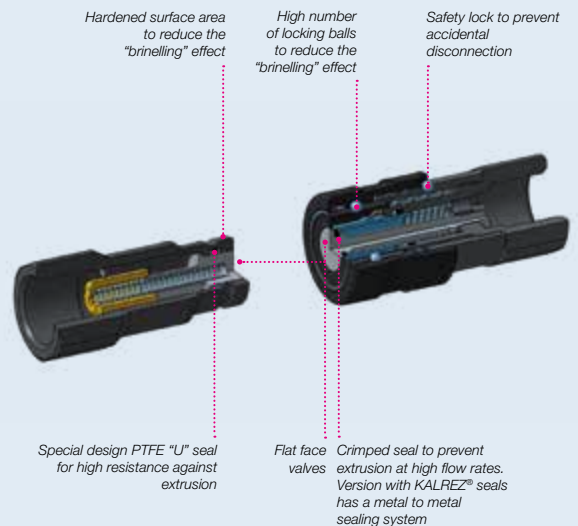
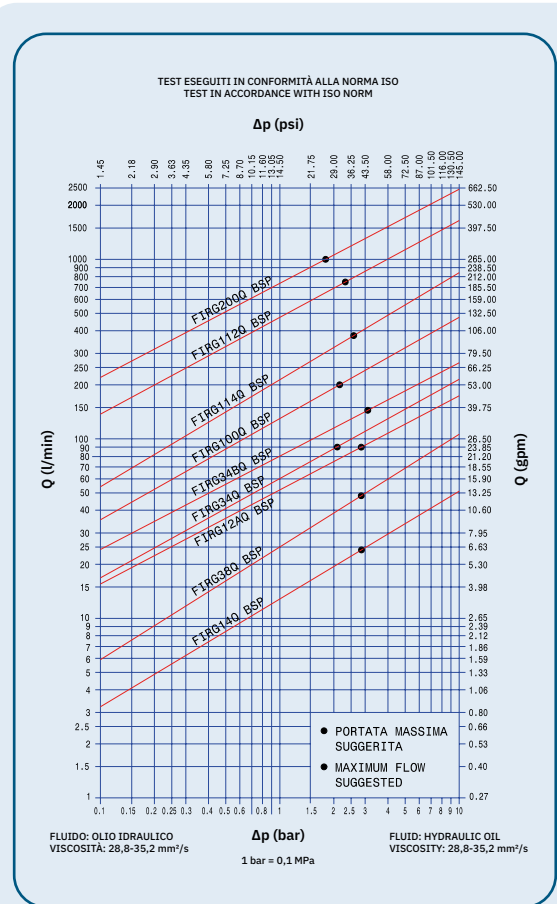

MAIN APPLICATIONS





PERFORMANCES

Size		Series/Size	Max. flow suggested		Connect force		Disconnect force		Spillage*
Inch	mm (ISO)		l/min	gpm	N	lbf	N	lbf	ml
1/4	6,3	FIRG14Q	24	6,36	130	29,25	45	10,13	0,01
3/8	10,0	FIRG38Q-12Q	46	12,19	160	36,00	35	7,88	0,01
1/2	12,5	FIRG12AQ-34Q	90	23,85	240	54,00	65	14,63	0,02
5/8	16,0	FIRG34BQ	148	39,22	190	42,75	60	13,50	0,02
3/4	19,0	FIRG100Q	200	53,00	220	49,50	70	15,75	0,03
1	25,0	FIRG114Q	378	100,17	310	69,75	100	22,50	0,03
1-1/2	-	FIRG112Q	750	198,75	400	90,00	100	22,50	0,05
2	-	FIRG200Q	1000	265,00	370	83,25	70	15,75	0,1

Data valid for couplings with NBR, VITON®, EPDM seals

Size	Series/Size	Max. operating pressure						Burst pressure					
		Coupled		Male		Female		Coupled		Male		Female	
Inch		MPa	psi	MPa	psi	MPa	psi	MPa	psi	MPa	psi	MPa	psi
1/4	FIRG14Q	30	4350	30	4350	12	1740	120	17400	120	17400	48	6960
3/8	FIRG38Q-12Q	30	4350	30	4350	15	2175	120	17400	120	17400	60	8700
1/2	FIRG12AQ-34Q	25	3625	25	3625	12	1740	100	14500	100	14500	48	6960
5/8	FIRG34BQ	25	3625	25	3625	12	1740	100	14500	100	14500	48	6960
3/4	FIRG100Q	25	3625	25	3625	10	1450	100	14500	90	13050	40	5800
1	FIRG114Q	25	3625	25	3625	10	1450	100	14500	90	13050	40	5800
1-1/2	FIRG112Q	20	2900	20	2900	8	1160	60	8700	60	8700	32	4640
2	FIRG200Q	20	2900	20	2900	8	1160	60	8700	60	8700	32	4640

Data valid for couplings with KALREZ® - SEALS FOR HIGH TEMPERATURE

Size	Series/Size	Max. operating pressure						Burst pressure					
		Coupled		Male		Female		Coupled		Male		Female	
Inch		MPa	psi	MPa	psi	MPa	psi	MPa	psi	MPa	psi	MPa	psi
1/4	FIRG14QK	5	725	5	725	5	725	120	17400	120	17400	40	5800
3/8	FIRG38Q-12QK	5	725	5	725	5	725	120	17400	120	17400	48	6960
1/2	FIRG12AQ-34QK	5	725	5	725	5	725	100	14500	100	14500	48	6960
5/8	FIRG34BQK	5	725	5	725	5	725	100	14500	100	14500	40	5800
3/4	FIRG100QK	5	725	5	725	5	725	100	14500	90	13050	60	8700
1	FIRG114QK	5	725	5	725	5	725	100	14500	90	13050	60	8700
1-1/2	FIRG112QK	5	725	5	725	5	725	40	5800	40	5800	32	4640
2	FIRG200QK	5	725	5	725	5	725	40	5800	40	5800	32	4640

* Spillage is an indicative value of the fluid loss during disconnection (according to ISO norm test method).

Temperature range:

FIRG QN - NBR (Nitrile) seals: from -20 °C to +100 °C (from -4 °F to +212 °F).
 FIRG QV - VITON® seals: from -15°C to +180°C (from +5 °F to +356 °F).
 FIRG QE - EPDM (Ethylene Propylene) seals: from -40°C to +150°C (from -40 °F to +302 °F).
 FIRG QK - KALREZ® seals: from -25°C to +300°C (from -13 °F to +572 °F).

The couplings with KALREZ® seals for high temperature use can be used at max. operating pressure of 5 Mpa (725 psi).

Please read carefully Instructions and warnings for proper selection of the products.

Tests:

The couplings have been tested at max. operating pressure for 100.000 impulses according to ISO norm test method.

! WARNING

A defect, a wrong choice or an improper use of products, can cause injury to persons, animals and objects.
 Never connect or disconnect with dynamic pressure (e.g. pump on).
 Do not use the female coupling disconnected with high impulse pressure.
 Do not couple-uncouple with flow and/or pressure in the circuit.
 Do not couple-uncouple when the temperature inside of the circuit is higher than 80 °C (176 °F).
 Check the maximum allowable working pressure of the port in use.
 Make sure that the medium used is compatible with seal and material as indicated for each series.
 In case of doubt please contact Stucchi Technical Support.

The interchangeability is mentioned under the assumption that the manufacturer of the considered products has not changed any dimension.
It is mandatory to carefully read and closely follow the instructions before selecting or using any Stucchi products.
Always refer to the version uploaded in the Instructions and warning section of stucchigroup.com website for the latest release.
For specific, product-related, instructions, please contact Stucchi technical service.

OVERALL DIMENSIONS

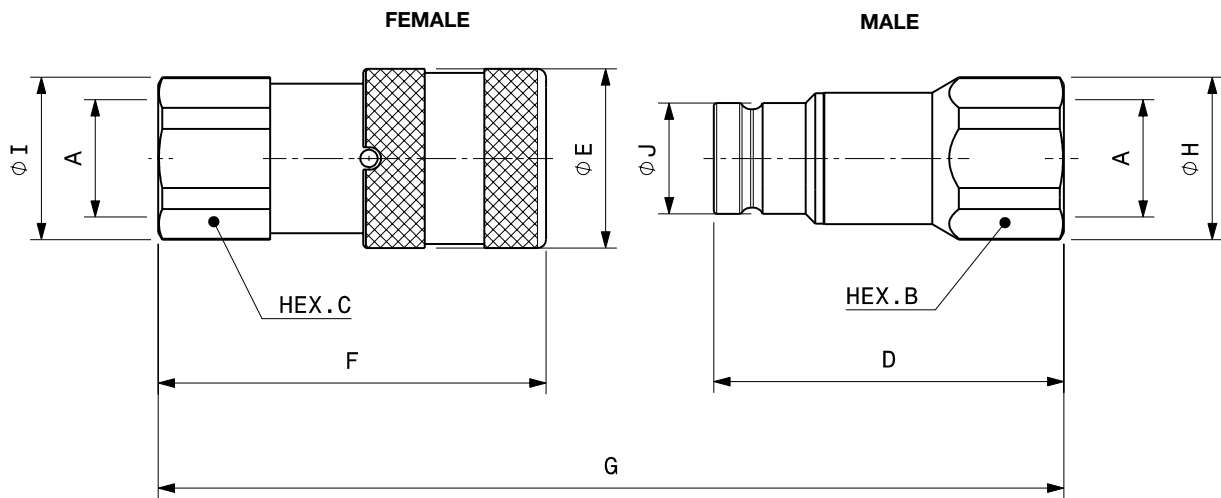

Port description: FEMALE THREAD BSPP (ISO 1179-1)

BODY SIZE	Descriptive Code	Item Code *	ISO DN	PORT (A)	G	Overall Length		Length			Hex		Diameter		Diameter		Weight				
						mm	inch	mm	inch	mm	inch	mm	inch	mm	inch	Kg	Lbs				
1/4"	F FIRG14Q BSP	Female	6,3	1/4"	G	85,2	3,35	F	48,1	1,89	C	22,0	0,87	I	24,0	0,94	E	28,0	1,10	0,14	0,31
	M FIRG14Q BSP	Male						D	47,9	1,89	B	22,0	0,87	H	23,8	0,94	J	16,0	0,63	0,09	0,19
3/8"	F FIRG38Q BSP	Female	10	3/8"	G	108,7	4,28	F	64,2	2,53	C	27,0	1,06	I	29,0	1,14	E	32,0	1,26	0,23	0,51
	M FIRG38Q BSP	Male						D	60,0	2,36	B	24,0	0,94	H	26,0	1,02	J	19,8	0,78	0,12	0,27
3/8"	F FIRG12Q BSP	Female	10	1/2"	G	116,2	4,57	F	69,2	2,72	C	27,0	1,06	I	29,0	1,14	E	32,0	1,26	0,23	0,51
	M FIRG12Q BSP	Male						D	62,5	2,46	B	27,0	1,06	H	29,0	1,14	J	19,8	0,78	0,12	0,26
1/2"	F FIRG12AQ BSP	Female	12,5	1/2"	G	124,5	4,90	F	73,8	2,91	C	32,0	1,26	I	33,8	1,33	E	38,0	1,50	0,37	0,82
	M FIRG12AQ BSP	Male						D	68,0	2,68	B	32,0	1,26	H	33,8	1,33	J	24,4	0,96	0,23	0,51
1/2"	F FIRG34Q BSP	Female	12,5	3/4"	G	134,0	5,28	F	80,8	3,18	C	36,0	1,42	I	38,5	1,52	E	38,0	1,50	0,37	0,82
	M FIRG34Q BSP	Male						D	70,5	2,78	B	36,0	1,42	H	38,5	1,52	J	24,5	0,96	0,23	0,51
5/8"	F FIRG34BQ BSP	Female	16	3/4"	G	131,4	5,17	F	78,5	3,09	C	36,0	1,42	I	38,5	1,52	E	42,0	1,65	0,47	1,04
	M FIRG34BQ BSP	Male						D	70,5	2,78	B	36,0	1,42	H	38,5	1,52	J	27,0	1,06	0,27	0,59
3/4"	F FIRG100Q BSP	Female	19	1"	G	153,5	6,04	F	93,2	3,67	C	45,0	1,77	I	47,8	1,88	E	48,0	1,89	0,77	1,69
	M FIRG100Q BSP	Male						D	82,3	3,24	B	45,0	1,77	H	47,8	1,88	J	30,0	1,18	0,40	0,87
1"	F FIRG114Q BSP	Female	25	1 1/4"	G	172,8	6,80	F	106,0	4,17	C	55,0	2,17	I	59,8	2,35	E	55,0	2,17	1,20	2,65
	M FIRG114Q BSP	Male						D	89,8	3,54	B	55,0	2,17	H	59,8	2,35	J	36,0	1,42	0,64	1,42
1-1/2"	F FIRG112Q BSP	Female	-	1 1/2"	G	214,8	8,46	F	132,4	5,21	C	65,0	2,56	I	72,0	2,83	E	80,0	3,15	2,82	6,22
	M FIRG112Q BSP	Male						D	111,0	4,37	B	70,0	2,76	H	76,0	2,99	J	57,0	2,24	1,86	4,10
2"	F FIRG200Q BSP	Female	-	2"	G	241,5	9,51	F	156,6	6,17	C	80,0	3,15	I	88,5	3,48	E	100,0	3,94	-	-
	M FIRG200Q BSP	Male						D	123,8	4,87	B	75,0	2,95	H	83,5	3,29	J	73,0	2,87	-	-

* For specific item code see "different seals configurations" page at the end of this section.

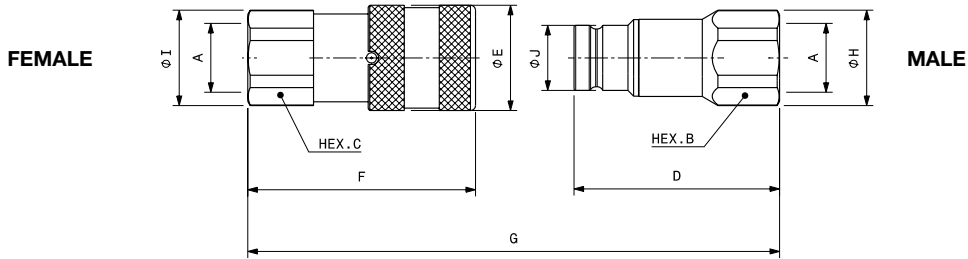

Port description: FEMALE THREAD NPT (ANSI B.1.20.1)

BODY SIZE	Descriptive Code	Item Code *	ISO DN	PORT (A)	Overall Length	Length		Hex		Diameter		Diameter		Weight							
						mm	inch	mm	inch	mm	inch	mm	inch	Kg	Lbs						
1/4"	F FIRG14Q NPT	Female	6,3	1/4"	G	85,2	3,35	F	48,1	1,89	C	22,0	0,87	I	24,0	0,94	E	28,0	1,10	0,14	0,30
	M FIRG14Q NPT	Male						D	47,9	1,89	B	22,0	0,87	H	23,8	0,94	J	16,1	0,63	0,09	0,19
3/8"	F FIRG38Q NPT	Female	10	3/8"	G	108,7	4,28	F	64,2	2,53	C	27,0	1,06	I	29,0	1,14	E	32,0	1,26	0,24	0,53
	M FIRG38Q NPT	Male						D	60,0	2,36	B	24,0	0,94	H	26,0	1,02	J	19,7	0,78	0,12	0,26
3/8"	F FIRG12Q NPT	Female	10	1/2"	G	116,2	4,57	F	69,2	2,72	C	27,0	1,06	I	29,0	1,14	E	32,0	1,26	0,24	0,52
	M FIRG12Q NPT	Male						D	62,5	2,46	B	27,0	1,06	H	29,0	1,14	J	19,7	0,78	0,13	0,29
1/2"	F FIRG12AQ NPT	Female	12,5	1/2"	G	124,5	4,90	F	73,8	2,91	C	32,0	1,26	I	33,8	1,33	E	38,0	1,50	0,38	0,85
	M FIRG12AQ NPT	Male						D	68,0	2,68	B	32,0	1,26	H	33,8	1,33	J	24,5	0,96	0,24	0,53
1/2"	F FIRG34Q NPT	Female	12,5	3/4"	G	134,0	5,28	F	80,8	3,18	C	36,0	1,42	I	38,5	1,52	E	38,0	1,50	0,43	0,95
	M FIRG34Q NPT	Male						D	70,5	2,78	B	36,0	1,42	H	38,5	1,52	J	24,5	0,96	0,23	0,50
5/8"	F FIRG34BQ NPT	Female	16	3/4"	G	131,4	5,17	F	78,5	3,09	C	36,0	1,42	I	38,5	1,52	E	42,0	1,65	0,47	1,04
	M FIRG34BQ NPT	Male						D	70,5	2,78	B	36,0	1,42	H	38,5	1,52	J	27,0	1,06	0,27	0,59
3/4"	F FIRG100Q NPT	Female	19	1"	G	153,5	6,04	F	93,2	3,67	C	45,0	1,77	I	47,8	1,88	E	48,0	1,89	0,77	1,69
	M FIRG100Q NPT	Male						D	82,3	3,24	B	45,0	1,77	H	47,8	1,88	J	30,0	1,18	0,41	0,90
1"	F FIRG114Q NPT	Female	25	1 1/4"	G	172,8	6,80	F	106,0	4,17	C	55,0	2,17	I	59,8	2,35	E	55,0	2,17	1,24	2,73
	M FIRG114Q NPT	Male						D	89,8	3,54	B	55,0	2,17	H	59,8	2,35	J	36,0	1,42	0,65	1,42
1-1/2"	F FIRG112Q NPT	Female	-	1 1/2"	G	214,8	8,46	F	132,4	5,21	C	65,0	2,56	I	72,0	2,83	E	80,0	3,15	2,82	6,22
	M FIRG112Q NPT	Male						D	111,0	4,37	B	70,0	2,76	H	76,0	2,99	J	57,0	2,24	1,87	4,11
2"	F FIRG200Q NPT	Female	-	2"	G	241,5	9,51	F	156,6	6,17	C	80,0	3,15	I	88,5	3,48	E	100,0	3,94	-	-
	M FIRG200Q NPT	Male						D	123,8	4,87	B	75,0	2,95	H	83,5	3,29	J	73,0	2,87	-	-

* For specific item code see "different seals configurations" page at the end of this section.

Panel mounting

FIRG-Q Series is available upon request also as panel mounting version:

BC: Snap Ring Solution
Grooves on the male body and on the female sleeve.

BT: Lock Ring Solution
Thread on the male body and female body.

For specific codes, dimensions or any other information, please contact Stucchi Technical Support.



SS version

For specific cases, FIRG-Q Series is available upon request without the safety lock ball.

For additional information, please contact Stucchi Technical Support.

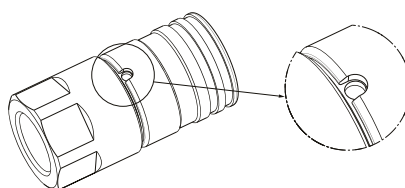



FLAT FACE

Port description: FEMALE THREAD BSPP (ISO 1179-1)

Different seals configurations

BODY	ISO	PORT (A)	NITRIL SEALS		VITON® SEALS		EPDM SEALS		KALREZ® SEALS	
SIZE	DN		Item Code	Descriptive Code	Item Code	Descriptive Code	Item Code	Descriptive Code	Item Code	Descriptive Code
1/4"	6,3	1/4"	800900000	F FIRG14QN BSP	800900100	F FIRG14QV BSP	800900200	F FIRG14QE BSP	800900704 *	F FIRG14QK BSP
			800900001	M FIRG14QN BSP	800900101	M FIRG14QV BSP	800900201	M FIRG14QE BSP	800900705 *	M FIRG14QK BSP
3/8"	10	3/8"	800900002	F FIRG38QN BSP	800900102	F FIRG38QV BSP	800900202	F FIRG38QE BSP	800900708 *	F FIRG38QK BSP
			800900003	M FIRG38QN BSP	800900103	M FIRG38QV BSP	800900203	M FIRG38QE BSP	800900709 *	M FIRG38QK BSP
3/8"	10	1/2"	800900004	F FIRG12QN BSP	800900104	F FIRG12QV BSP	800900204	F FIRG12QE BSP	800900710 *	F FIRG12QK BSP
			800900005	M FIRG12QN BSP	800900105	M FIRG12QV BSP	800900205	M FIRG12QE BSP	800900711 *	M FIRG12QK BSP
1/2"	12,5	1/2"	800900006	F FIRG12AQN BSP	800900106	F FIRG12AQV BSP	800900206	F FIRG12AQE BSP	800900700 *	F FIRG12AQK BSP
			800900007	M FIRG12AQN BSP	800900107	M FIRG12AQV BSP	800900207	M FIRG12AQE BSP	800900701 *	M FIRG12AQK BSP
1/2"	12,5	3/4"	800900008	F FIRG34QN BSP	800900108	F FIRG34QV BSP	800900208	F FIRG34QE BSP	800900712 *	F FIRG34QK BSP
			800900009	M FIRG34QN BSP	800900109	M FIRG34QV BSP	800900209	M FIRG34QE BSP	800900713 *	M FIRG34QK BSP
5/8"	16	3/4"	800900010	F FIRG34BQN BSP	800900110	F FIRG34BQV BSP	800900210	F FIRG34BQE BSP	800900716 *	F FIRG34BQK BSP
			800900011	M FIRG34BQN BSP	800900111	M FIRG34BQV BSP	800900211	M FIRG34BQE BSP	800900717 *	M FIRG34BQK BSP
3/4"	19	1"	800900012	F FIRG100QN BSP	800900112	F FIRG100QV BSP	800900212	F FIRG100QE BSP	800900702 *	F FIRG100QK BSP
			800900013	M FIRG100QN BSP	800900113	M FIRG100QV BSP	800900213	M FIRG100QE BSP	800900703 *	M FIRG100QK BSP
1"	25	1-1/4"	800900014	F FIRG114QN BSP	800900114	F FIRG114QV BSP	800900214 *	F FIRG114QE BSP	800900706 *	F FIRG114QK BSP
			800900015	M FIRG114QN BSP	800900115	M FIRG114QV BSP	800900215 *	M FIRG114QE BSP	800900707 *	M FIRG114QK BSP
1-1/2"	-	1-1/2"	800900016 *	F FIRG112QN BSP	800900116	F FIRG112QV BSP	800900216 *	F FIRG112QE BSP	800900718 *	F FIRG112QK BSP
			800900017 *	M FIRG112QN BSP	800900117	M FIRG112QV BSP	800900217 *	M FIRG112QE BSP	800900719 *	M FIRG112QK BSP
2"	-	2"	800900022 *	F FIRG200QN BSP	800900120 *	F FIRG200QV BSP	800900218 *	F FIRG200QE BSP	800900722 *	F FIRG200QK BSP
			800900023 *	M FIRG200QN BSP	800900121 *	M FIRG200QV BSP	800900219 *	M FIRG200QE BSP	800900723 *	M FIRG200QK BSP

* Available upon request.

Port description: FEMALE THREAD NPT (ANSI B.1.20.1)

BODY	ISO	PORT (A)	NITRIL SEALS		VITON® SEALS		EPDM SEALS	
SIZE	DN		Item Code	Descriptive Code	Item Code	Descriptive Code	Item Code	Descriptive Code
1/4"	6,3	1/4"	800901000	F FIRG14QN NPT	800901100	F FIRG14QV NPT	800901200 *	F FIRG14QE NPT
			800901001	M FIRG14QN NPT	800901101	M FIRG14QV NPT	800901201 *	M FIRG14QE NPT
3/8"	10	3/8"	800901002	F FIRG38QN NPT	800901102	F FIRG38QV NPT	800901202	F FIRG38QE NPT
			800901003	M FIRG38QN NPT	800901103	M FIRG38QV NPT	800901203	M FIRG38QE NPT
3/8"	10	1/2"	800901004	F FIRG12QN NPT	800901104	F FIRG12QV NPT	800901204 *	F FIRG12QE NPT
			800901005	M FIRG12QN NPT	800901105	M FIRG12QV NPT	800901205 *	M FIRG12QE NPT
1/2"	12,5	1/2"	800901006	F FIRG12AQN NPT	800901106	F FIRG12AQV NPT	800901206	F FIRG12AQE NPT
			800901007	M FIRG12AQN NPT	800901107	M FIRG12AQV NPT	800901207	M FIRG12AQE NPT
1/2"	12,5	3/4"	800901008	F FIRG34QN NPT	800901108 *	F FIRG34QV NPT	800901208	F FIRG34QE NPT
			800901009	M FIRG34QN NPT	800901109 *	M FIRG34QV NPT	800901209	M FIRG34QE NPT
5/8"	16	3/4"	800901010	F FIRG34BQN NPT	800901110	F FIRG34BQV NPT	800901210 *	F FIRG34BQE NPT
			800901011	M FIRG34BQN NPT	800901111	M FIRG34BQV NPT	800901211 *	M FIRG34BQE NPT
3/4"	19	1"	800901012	F FIRG100QN NPT	800901112	F FIRG100QV NPT	800901212 *	F FIRG100QE NPT
			800901013	M FIRG100QN NPT	800901113	M FIRG100QV NPT	800901213 *	M FIRG100QE NPT
1"	25	1-1/4"	800901014	F FIRG114QN NPT	800901114	F FIRG114QV NPT	800901214 *	F FIRG114QE NPT
			800901015	M FIRG114QN NPT	800901115	M FIRG114QV NPT	800901215 *	M FIRG114QE NPT
1-1/2"	-	1-1/2"	800901016	F FIRG112QN NPT	800901116 *	F FIRG112QV NPT	800901216 *	F FIRG112QE NPT
			800901017	M FIRG112QN NPT	800901117 *	M FIRG112QV NPT	800901217 *	M FIRG112QE NPT
2"	-	2"	800901018 *	F FIRG200QN NPT	800901118 *	F FIRG200QV NPT		
			800901019 *	M FIRG200QN NPT	800901119 *	M FIRG200QV NPT		

* Available upon request.



SPARE KIT SEAL FOR MALE

Repair kit / OR+BK		
Body Size	Description	Part Number
1/4"	M FIRG14Q	815700519
3/8"	M FIRG38Q-12Q	815700337
1/2"	M FIRG12AQ-34Q	815700339
5/8"	M FIRG34BQ	815700341
3/4"	M FIRG100Q	815700343
1"	M FIRG114Q	815700345
1 1/2"	M FIRG112Q	815700521

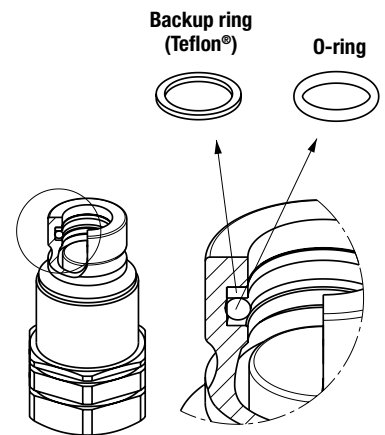

O-Ring in Nitrile
BackUp in Teflon®

PROTECTIVE CAPS FOR FIRG-Q SERIES

Protective caps are always recommended to protect the couplings from damage, dirt inclusion, and will increase the product life.

For the FIRG-Q series are available two kind of materials:

- Plastic caps with lanyard (standard color: red, other colors available upon request)
- aluminum caps with lanyard (standard colors: natural aluminum, other colors available upon request)

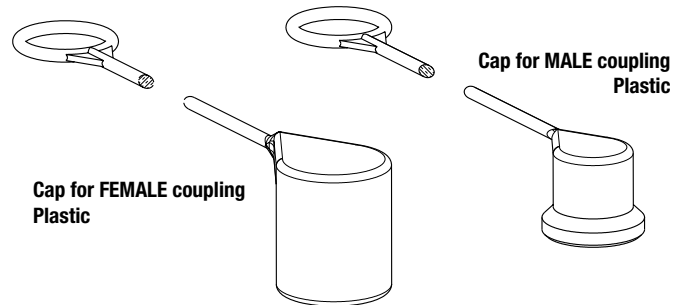

Body Size/Description	Protective Cap		Material/Color
	Part Number	Part Number	
	Cap for Female	Cap for Male	
1/4" FIRG14Q	815100000	815100023	Plastic/Red
3/8" FIRG38Q-12Q	815100002	815100027	Plastic/Red
1/2" FIRG12AQ-34Q	815100006	815100031	Plastic/Red
5/8" FIRG34BQ	815100008	815100011	Plastic/Red
3/4" FIRG100Q	815100010	815100013	Plastic/Red
1" FIRG114Q	815100012	815100015	Plastic/Red

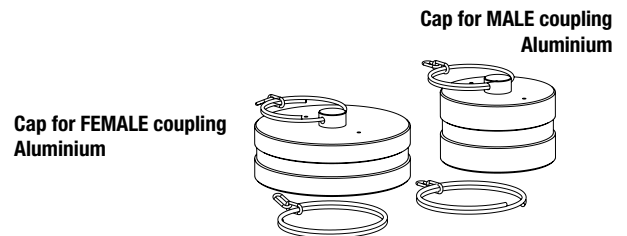

Body Size/Description	Protective Cap		Material/Color
	Part Number	Part Number	
	Cap for Female	Cap for Male	
1/4" FIRG14Q	816005002	816005003	Aluminum/Natural
3/8" FIRG38Q-12Q	816005004	816005005	Aluminum/Natural
1/2" FIRG12AQ-34Q	816005006	816005007	Aluminum/Natural
5/8" FIRG34BQ	816005008	816005009	Aluminum/Natural
3/4" FIRG100Q	816005010	816005011	Aluminum/Natural
1" FIRG114Q	816005012	816005013	Aluminum/Natural



FL SERIES

INTERCHANGE > ISO 16028 - NFPA T3.20.15 - HTMA (size 3/8")















Stucchi®

FLAT FACE



TECHNICAL FEATURES AND OPTIONS

 Interchange ISO 16028 NFPA T3.20.15 HTMA (size 3/8")	 Sealing description FKM (VITON®)	 Connection system Push
 Available sizes from 1/8" to 2"	 Material Stainless steel (AISI 316L)	 Available threads BSP - NPT - SAE
 Operating pressure Up to 350 bar	 Locking mechanism Locking ball + Safety Lock	 Flow rate Up to 1000 l/min
 Temperature (°C) -15° / +180°	 Valving style Flat face	 Connection under pressure Connection: not allowed Disconnection: not allowed

BENEFITS

- Flat face is easy to clean, reducing the inclusion of contamination inside the hydraulic circuit.
- Minimal fluid spillage during disconnection, reducing fluid spillage to the environment.
- Minimal air inclusion during connection.
- Optimal resistance to the corrosion for long life of couplings.
- Compact slim design.
- Safe and simple to use.

HOW TO USE

- Before to connect, clean the mating surface of the couplings to avoid dirt inclusion in the circuit.
- To connect push the male half towards the female half or vice versa.
- After connection turn the external sleeve to engage safety lock function, to prevent accidental disconnection.
- To disconnect turn the external sleeve until the sleeve lock notch match the safety lock ball and push back the sleeve.

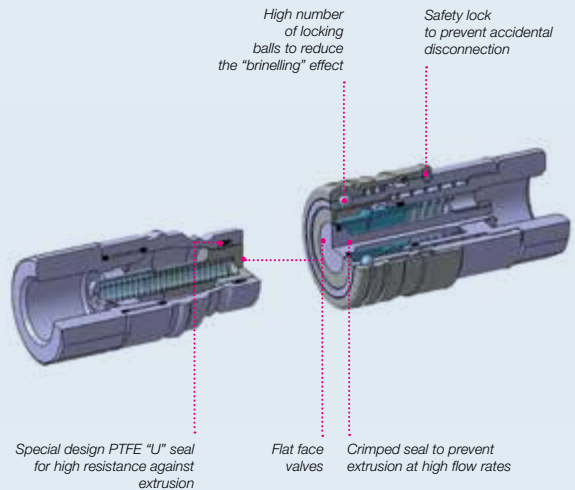
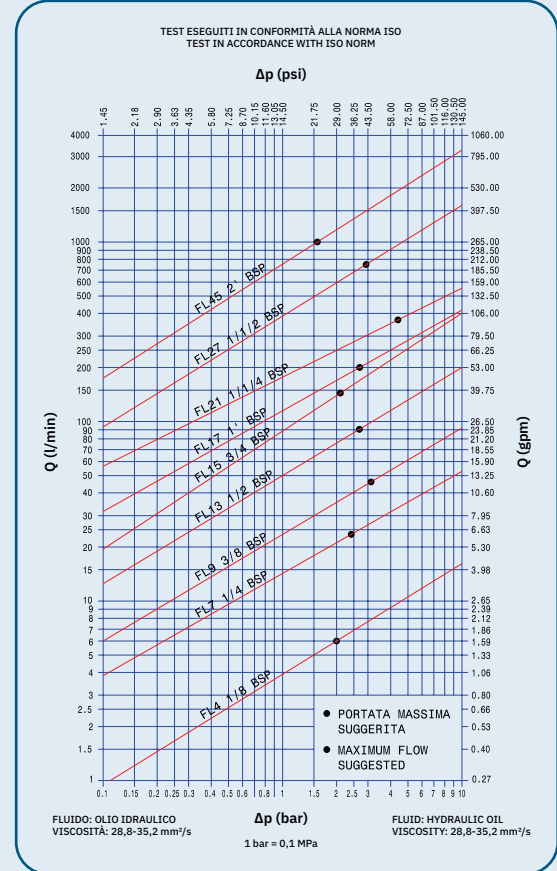

MAIN APPLICATIONS





PERFORMANCES

Size		Series/Size	Max. flow suggested		Connect force		Disconnect force		Spillage*
Inch	mm (ISO)		l/min	gpm	N	lbf	N	lbf	ml
1/8		FL4	6	1,59	140	31,50	30	6,75	0,01
1/4	6,3	FL7	24	6,36	160	36,00	45	10,13	0,01
3/8	10,0	FL9	46	12,19	160	36,00	45	10,13	0,01
1/2	12,5	FL13	90	23,85	200	45,00	60	13,50	0,02
5/8	16,0	FL15	148	39,22	200	45,00	60	13,50	0,03
3/4	19,0	FL17	200	53,00	200	45,00	60	13,50	0,03
1	25,0	FL21	378	100,17	280	63,00	90	20,25	0,04
1-1/2		FL27	750	198,75	580	130,50	160	36,00	0,05
2		FL45	1000	265,00	490	110,25	70	15,75	0,10

Size	Series/Size	Max. operating pressure						Burst pressure					
		Coupled		Male		Female		Coupled		Male		Female	
Inch		MPa	psi	MPa	psi	MPa	psi	MPa	psi	MPa	psi	MPa	psi
1/8	FL4	35	5075	35	5075	33	4785	140	20300	140	20300	120	17400
1/4	FL7	35	5075	35	5075	12	1740	140	20300	120	17400	48	6960
3/8	FL9	35	5075	35	5075	15	2175	140	20300	120	17400	60	8700
1/2	FL13	35	5075	35	5075	15	2175	120	17400	110	15950	60	8700
5/8	FL15	35	5075	30	4350	12	1740	120	17400	100	14500	48	6960
3/4	FL17	33	4785	28	4060	12	1740	100	14500	80	11600	48	6960
1	FL21	28	4060	28	4060	12	1740	90	13050	80	11600	48	6960
1-1/2	FL27	23	3335	23	3335	8	1160	80	11600	70	10150	32	4640
2	FL45	15	2175	15	2175	7	1015	60	8700	60	8700	28	4060

* Spillage is an indicative value of the fluid loss during disconnection (according to ISO norm test method).

Material:

- Construction: Stainless steel AISI 316L
- Springs: AISI 302
- Locking ball: AISI 316

Different possible configurations:

SAE thread available upon request.

Temperature range:

Standard seals in VITON®: from -15°C to +180°C (from +5 °F to +356 °F).

Upon request seals in NBR (Nitrile): from -20 °C to +100 °C

(from -4 °F to +212 °F).

Upon request seals in EPDM (Ethylene Propylene) seals: from -40 °C to +150 °C

(from -40 °F to +302 °F).

Upon request seals in KALREZ® seals: from -25 °C to +300 °C

(from -13 °F to +572 °F).

The couplings with KALREZ® seals for high temperature use can be used at max. operating pressure of 5 Mpa (725 psi).

Please read carefully Instructions and warnings for proper selection of the products.

Tests performed:

The couplings have been tested at max. operating pressure for 100.000 impulses according to ISO norm test method.



WARNING

A defect, a wrong choice or an improper use of products, can cause injury to persons, animals and objects.

Never connect or disconnect with dynamic pressure (e.g. pump on).

Do not use the female coupling disconnected with high impulse pressure.

Do not couple-uncouple with flow and/or pressure in the circuit.

Do not couple-uncouple when the temperature inside of the circuit is higher than 80 °C (176 °F).

Check the maximum allowable working pressure of the port in use.

Make sure that the medium used is compatible with seal and material as indicated for each series.

In case of doubt please contact Stucchi Technical Support.

The interchangeability is mentioned under the assumption that the manufacturer of the considered products has not changed any dimension.

It is mandatory to carefully read and closely follow the instructions before selecting or using any Stucchi products.

Always refer to the version uploaded in the Instructions and warning section of stucchigroup.com website for the latest release.

For specific, product-related, instructions, please contact Stucchi technical service.

OVERALL DIMENSIONS

FLAT FACE

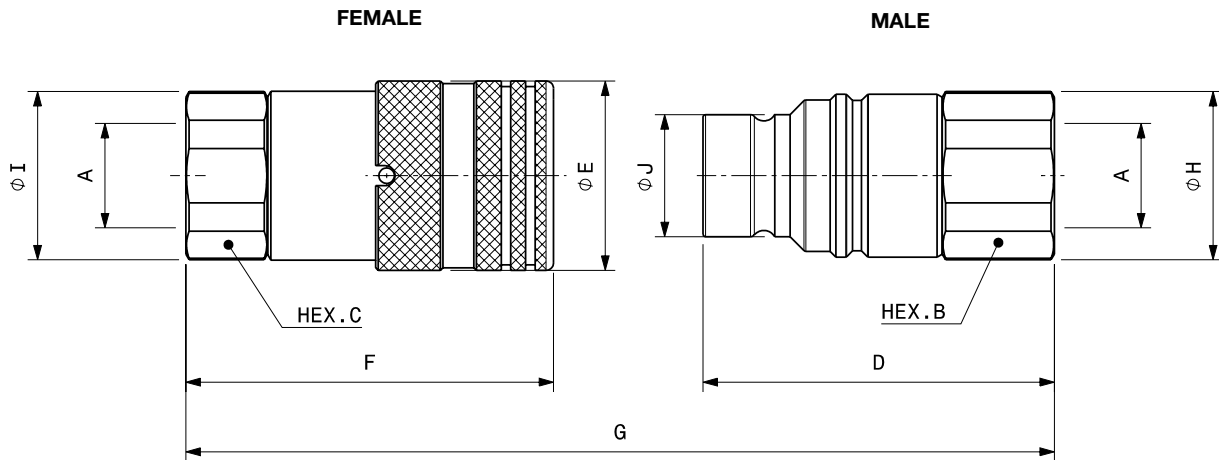

Port description: FEMALE THREAD BSPP (ISO 1179-1)

BODY SIZE	Descriptive Code	Item Code	ISO DN	PORT (A)	Overall Length	Length		Hex		Diameter		Diameter		Weight							
						mm	inch	mm	inch	mm	inch	mm	inch	Kg	Lbs						
1/8"	F FL4 1/8 BSP	Female 802400122	-	1/8"	G	68,4	2,69	F	40,0	1,57	C	19,0	0,75	I	20,5	0,81	E	20,0	0,79	0,07	0,16
	M FL4 1/8 BSP	Male 802400123						D	36,3	1,43	B	17,0	0,67	H	18,5	0,73	J	11,6	0,46	0,04	0,08
1/4"	F FL7 1/4 BSP	Female 802400100	6,3	1/4"	G	86,7	3,41	F	48,3	1,90	C	22,0	0,87	I	23,8	0,94	E	28,0	1,10	0,14	0,31
	M FL7 1/4 BSP	Male 802400101						D	49,4	1,94	B	22,0	0,87	H	23,8	0,94	J	16,1	0,63	0,10	0,22
3/8"	F FL9 3/8 BSP	Female 802400102	10	3/8"	G	108,6	4,28	F	64,2	2,53	C	27,0	1,06	I	29,0	1,14	E	32,0	1,26	0,25	0,54
	M FL9 3/8 BSP	Male 802400103						D	59,9	2,36	B	24,0	0,94	H	26,0	1,02	J	19,7	0,78	0,12	0,27
3/8"	F FL9 1/2 BSP	Female 802400104	10	1/2"	G	116,1	4,57	F	69,2	2,72	C	27,0	1,06	I	29,0	1,14	E	32,0	1,26	0,24	0,53
	M FL9 1/2 BSP	Male 802400105						D	62,4	2,46	B	27,0	1,06	H	29,0	1,14	J	19,7	0,78	0,12	0,26
1/2"	F FL13 1/2 BSP	Female 802400106	12,5	1/2"	G	127,0	5,00	F	73,8	2,91	C	32,0	1,26	I	33,8	1,33	E	38,0	1,50	0,38	0,83
	M FL13 1/2 BSP	Male 802400107						D	70,5	2,78	B	32,0	1,26	H	33,8	1,33	J	24,5	0,96	0,26	0,57
1/2"	F FL13 3/4 BSP	Female 802400108	12,5	3/4"	G	134,0	5,28	F	80,8	3,18	C	36,0	1,42	I	38,5	1,52	E	38,0	1,50	0,38	0,83
	M FL13 3/4 BSP	Male 802400109						D	70,5	2,78	B	36,0	1,42	H	38,5	1,52	J	24,5	0,96	0,26	0,56
5/8"	F FL15 3/4 BSP	Female 802400110	16	3/4"	G	133,8	5,27	F	80,9	3,19	C	36,0	1,42	I	38,5	1,52	E	42,0	1,65	0,49	1,08
	M FL15 3/4 BSP	Male 802400111						D	70,5	2,78	B	36,0	1,42	H	38,5	1,52	J	27,0	1,06	0,28	0,62
3/4"	F FL17 1 BSP	Female 802400112	19	1"	G	153,3	6,04	F	92,9	3,66	C	46,0	1,81	I	49,5	1,95	E	48,0	1,89	0,80	1,75
	M FL17 1 BSP	Male 802400113						D	82,2	3,24	B	46,0	1,81	H	49,5	1,95	J	30,0	1,18	0,43	0,95
1"	F FL21 1-1/4 BSP	Female 802400114	25	1 1/4"	G	173,0	6,81	F	106,2	4,18	C	55,0	2,17	I	59,8	2,35	E	55,0	2,17	1,23	2,70
	M FL21 1-1/4 BSP	Male 802400115						D	90,0	3,54	B	55,0	2,17	H	59,8	2,35	J	36,0	1,42	0,67	1,48
1-1/2"	F FL27 1-1/2 BSP	Female 802400116	-	1 1/2"	G	214,8	8,46	F	132,4	5,21	C	65,0	2,56	I	72,0	2,83	E	80,0	3,15	2,91	6,41
	M FL27 1-1/2 BSP	Male 802400117						D	111,0	4,37	B	70,0	2,76	H	76,0	2,99	J	57,0	2,24	1,89	4,17
2"	F FL45 2 BSP	Female 802400118	-	2"	G	241,5	9,51	F	156,6	6,17	C	80,0	3,15	I	88,5	3,48	E	100,0	3,94	5,23	11,53
	M FL45 2 BSP	Male 802400119						D	123,8	4,87	B	75,0	2,95	H	83,5	3,29	J	73,0	2,87	2,29	5,05

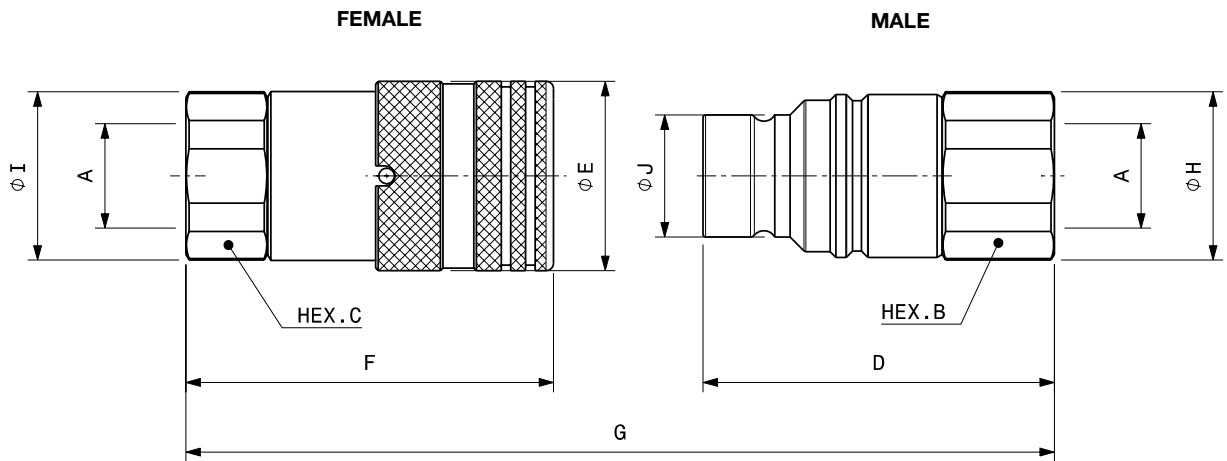

Port description: FEMALE THREAD NPT (ANSI B.1.20.1)

BODY SIZE	Descriptive Code	Item Code	ISO DN	PORT (A)	Overall Length	Length		Hex		Diameter		Diameter		Weight							
						mm	inch	mm	inch	mm	inch	mm	inch	mm	inch	Kg	Lbs				
1/8	F FL4 1/8 NPT	Female 802401118	-	1/8"	G	68,4	2,69	F	40,0	1,57	C	19,0	0,75	I	20,5	0,81	E	20,0	0,79	0,08	0,17
	M FL4 1/8 NPT	Male 802401119						D	36,3	1,43	B	17,0	0,67	H	18,5	0,73	J	11,6	0,46	0,04	0,09
1/4	F FL7 1/4 NPT	Female 802401100	6,3	1/4"	G	85,2	3,35	F	48,3	1,90	C	22,0	0,87	I	23,8	0,94	E	28,0	1,10	0,14	0,32
	M FL7 1/4 NPT	Male 802401101						D	47,9	1,89	B	22,0	0,87	H	23,8	0,94	J	16,1	0,63	0,09	0,21
3/8	F FL9 3/8 NPT	Female 802401102	10	3/8"	G	108,6	4,27	F	64,2	2,53	C	27,0	1,06	I	29,0	1,14	E	32,0	1,26	0,25	0,54
	M FL9 3/8 NPT	Male 802401103						D	59,9	2,36	B	24,0	0,94	H	26,0	1,02	J	19,7	0,78	0,14	0,30
3/8	F FL9 1/2 NPT	Female 802401104	10	1/2"	G	116,1	4,57	F	69,2	2,72	C	27,0	1,06	I	29,0	1,14	E	32,0	1,26	0,24	0,53
	M FL9 1/2 NPT	Male 802401105						D	62,4	2,46	B	27,0	1,06	H	29,0	1,14	J	19,7	0,78	0,14	0,30
1/2	F FL13 1/2 NPT	Female 802401106	12,5	1/2"	G	124,5	4,90	F	73,8	2,91	C	32,0	1,26	I	33,8	1,33	E	38,0	1,50	0,38	0,83
	M FL13 1/2 NPT	Male 802401107						D	68,0	2,68	B	32,0	1,26	H	33,8	1,33	J	24,5	0,96	0,26	0,57
1/2	F FL13 3/4 NPT	Female 802401108	12,5	3/4"	G	134	5,27	F	80,8	3,18	C	36,0	1,42	I	38,5	1,52	E	38,0	1,50	0,42	0,92
	M FL13 3/4 NPT	Male 802401109						D	70,5	2,78	B	36,0	1,42	H	38,5	1,52	J	24,5	0,96	0,27	0,59
5/8	F FL15 3/4 NPT	Female 802401110	16	3/4"	G	133,8	5,26	F	80,9	3,19	C	36,0	1,42	I	38,5	1,52	E	42,0	1,65	0,50	1,09
	M FL15 3/4 NPT	Male 802401111						D	70,5	2,78	B	36,0	1,42	H	38,5	1,52	J	27,0	1,06	0,28	0,62
3/4	F FL17 1 NPT	Female 802401112	19	1"	G	153,3	6,03	F	92,9	3,66	C	46,0	1,81	I	49,5	1,95	E	48,0	1,89	0,81	1,79
	M FL17 1 NPT	Male 802401113						D	82,2	3,24	B	46,0	1,81	H	49,5	1,95	J	30,0	1,18	0,43	0,95
1	F FL21 1-1/4 NPT	Female 802401114	25	1 1/4"	G	173	6,81	F	106,2	4,18	C	55,0	2,17	I	59,8	2,35	E	55,0	2,17	1,27	2,80
	M FL21 1-1/4 NPT	Male 802401115						D	90,0	3,54	B	55,0	2,17	H	59,8	2,35	J	36,0	1,42	0,78	1,72
1-1/2	F FL27 1-1/2 NPT	Female 802401116	-	1 1/2"	G	214,8	8,45	F	132,4	5,21	C	65,0	2,56	I	72,0	2,83	E	80,0	3,15	2,91	6,41
	M FL27 1-1/2 NPT	Male 802401117						D	111,0	4,37	B	70,0	2,76	H	76,0	2,99	J	57,0	2,24	1,90	4,18
2	F FL45 2 NPT	Female 802401120	-	2"	G	241,5	9,50	F	156,6	6,17	C	80,0	3,15	I	88,5	3,48	E	100,0	3,94	-	-
	M FL45 2 NPT	Male 802401121						D	123,8	4,87	B	75,0	2,95	H	83,5	3,29	J	73,0	2,87	-	-



SPARE KIT SEAL FOR MALE

Repair kit / OR+BK		
Body Size	Description	Part Number
3/8"	M FL9	815700247
1/2"	M FL13	815700249
5/8"	M FL15	815700251
3/4"	M FL17	815700253
1"	M FL21	815700255
1-1/2"	M FL 27	815700525
2"	M FL45	815700798

Back-up ring (Teflon®) o-ring

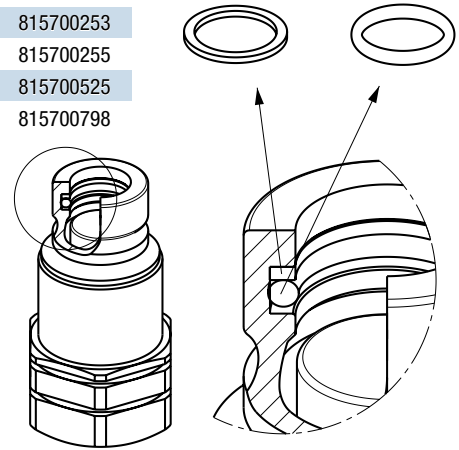

O-Ring in Viton®
BackUp in Teflon®

PROTECTIVE CAPS FOR FL SERIES

Protective caps are always recommended to protect the couplings from damage, dirt inclusion, and will increase the product life. This is particularly important in mobile applications where exposure to weather and aggregate materials are common.

The protective caps for FL couplings are manufactured in aluminum with lanyard (colors: natural aluminum).

Cap for FEMALE coupling
Aluminum

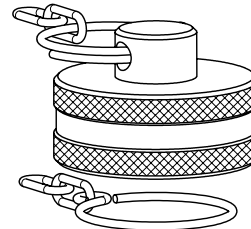

Cap for MALE coupling
Aluminum

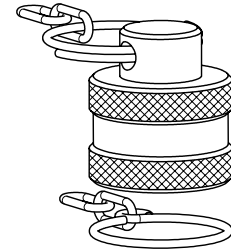

Body Size/Description	Protective Cap		Material/Color
	Part Number	Part Number	
	Cap for Female	Cap for Male	
1/4" FL7	816005002	816005003	Aluminum/Natural
3/8" FL9	816005004	816005005	Aluminum/Natural
1/2" FL13	816005006	816005007	Aluminum/Natural
5/8" FL15	816005008	816005009	Aluminum/Natural
3/4" FL17	816005010	816005011	Aluminum/Natural
1" FL21	816005012	816005013	Aluminum/Natural
1-1/2" FL27	815105014	815105017	Aluminum/Natural
2" FL45	815105016	815105019	Aluminum/Natural

Cap for FEMALE coupling
Aluminium

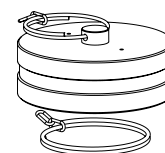

Cap for MALE coupling
Aluminium



The protective caps for FL couplings are also available in plastic (see A series caps at page 37).



Flat Face Screw



Easy
CUP

BOP



VEP-P

p. 73

Valving style: Flat face
Interchange: Stucchi profile
Sealing description: Nitrile NBR
Available sizes: From 1/4" to 2"
Operating pressure: Up to 600 bar
Flow rate: Up to 1000 l/min
Material / Treatment:
Carbon steel / Cr3+QPQ
Connection under pressure:
Allowed

Easy
CUP

BOP



VEP-HD

p. 81

Valving style: Flat face
Interchange: Stucchi profile
Sealing description: Nitrile NBR
Available sizes: From 5/8" to 1-1/2"
Operating pressure: Up to 550 bar
Flow rate: Up to 750 l/min
Material / Treatment:
Carbon steel / QPQ
Connection under pressure:
Allowed

Easy
CUP

BOP



VP-P

p. 89

Valving style: Flat face
Interchange: Stucchi profile
Sealing description: Nitrile NBR
Available sizes: From 1/4" to 1-1/2"
Operating pressure: Up to 600 bar
Flow rate: Up to 750 l/min
Material / Treatment:
Carbon steel / Cr3+QPQ
Connection under pressure:
Allowed



VEP-P SERIES

INTERCHANGE > Stucchi VEP profile



Easy CUP

BOP



TECHNICAL FEATURES AND OPTIONS

Interchange Stucchi VEP profile	Sealing description Nitrile NBR	Connection system Screw
Available sizes from 1/4" to 2"	Material/treatment Carbon steel /Cr3+QPQ	Available threads BSP - NPT - SAE
Operating pressure Up to 600 bar	Locking mechanism Screw to connect	Flow rate Up to 1000 l/min
Temperature (°C) -20° / +100°	Valving style Flat face	Connection under pressure Connection: Both side (see Benefits). Disconnection: Allowed (see Benefits).

BENEFITS

- Easy connection/disconnection with both side under residual pressure thanks to the Stucchi design.
- Flat face is easy to clean, reducing the inclusion of contamination inside the hydraulic circuit.
- Specific dimensions of Stucchi VEP-P series are certified with Lloyd Type Approval in accordance with API 16D at specific rating pressure of 345 bar/5000 PSI. For complete technical information please contact technical Stucchi support.
- Minimal fluid spillage during disconnection, reducing fluid spillage to the environment.
- Minimal air inclusion during connection.
- Internal valve design creates minimal pressure drop, maintaining circuit efficiency in the system
- Internal pressure release valve system allows an easy connection with high internal residual pressure.
- The modular design allows flexibility with a wide range of configurations.
- High resistance to pressure impulses.
- Safe and simple to use.

HOW TO USE

- Before to connect, clean the mating surface of the couplings to avoid dirt inclusion in the circuit.
- To connect pull forward the connection sleeve of the female coupling.
- Align the female and male coupling holding forward the connection sleeve and thread together turning the sleeve.
- Keep couplers aligned during connection process. Do not push to connect couplings.
- The screwing of the threads should be done by hand without the use of the tools for the first part of the connection.
- The use of tools for the second part of connection can be necessary if there is high residual pressure in the circuit.
- Screw the connecting sleeve of the female until metal surface contact with the male coupling is complete.
- Tighten the sleeve to the base of the male using the tightening torque spec. as indicated in the table below.
- To disconnect turn sleeve from contact position using a wrench, then unscrew making sure the couplings stay aligned through the entire process.

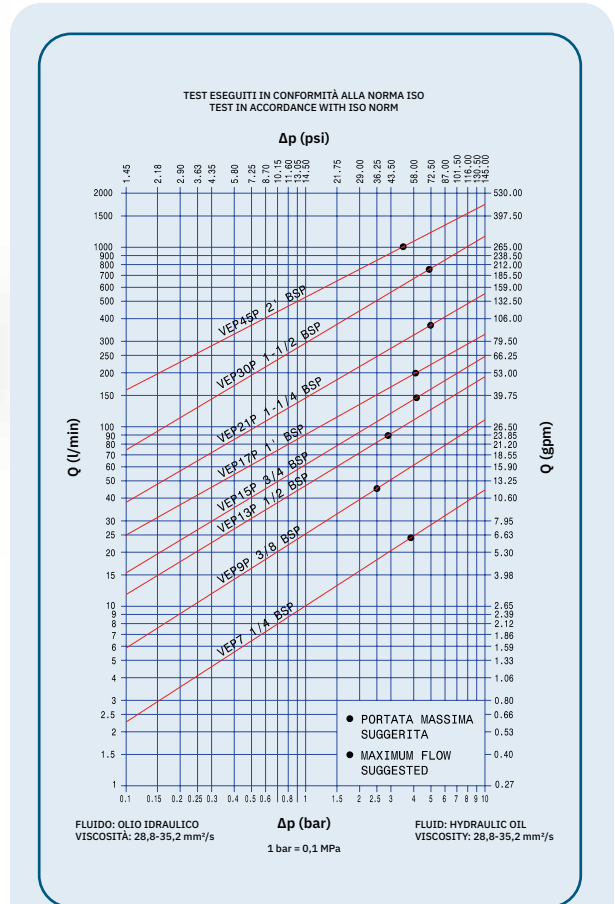

FLAT FACE SCREW

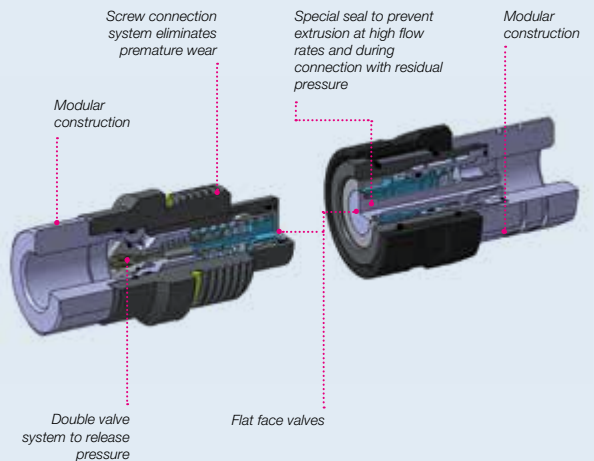

MAIN APPLICATIONS

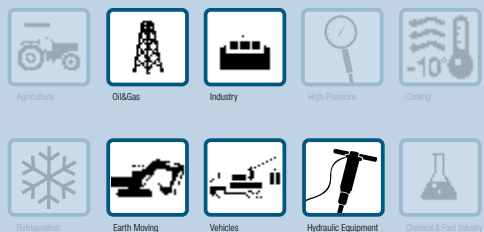

PERFORMANCES

Size	Series/Size	Max. flow suggested		Manual connect torque		Manual disconnect torque		Tightening torque		Spillage*
		l/min	gpm	Nm	lbf ft	Nm	lbf ft	Nm	lbf ft	
1/4	VEP7	24	6,36	2,8	2,06	1,9	1,40	40-50	29-37	0,01
3/8	VEP9P	46	12,19	2,2	1,62	1,4	1,03	50-60	37-44	0,04
1/2	VEP13P	90	23,85	1,8	1,33	1,4	1,03	65-75	48-55	0,02
5/8	VEP15P**	148	39,22	3,0	2,21	1,8	1,33	70-80	52-59	0,03
3/4	VEP17P**	200	53,00	5,6	4,13	3,6	2,65	90-110	66-81	0,01
1	VEP21P**	378	100,17	8,2	6,04	5,8	4,27	125-145	92-107	0,06
1-1/2	VEP30P**	750	198,75	26,0	19,16	12,5	9,21	155-175	114-129	0,20
2	VEP45P	1000	265,00	40,0	29,48	40,0	29,48	320-350	236-258	0,35

Size	Series/Size	Max. operating pressure						Burst pressure					
		Coupled		Male		Female		Coupled		Male		Female	
Inch		MPa	psi	MPa	psi	MPa	psi	MPa	psi	MPa	psi	MPa	psi
1/4	VEP7	60	8700	60	8700	42	6090	150	21750	150	21750	126	18270
3/8	VEP9P	55	7975	55	7975	33	4785	140	20300	140	20300	100	14500
1/2	VEP13P	55	7975	55	7975	33	4785	140	20300	140	20300	100	14500
5/8	VEP15P**	55	7975	55	7975	33	4785	140	20300	140	20300	100	14500
3/4	VEP17P**	50	7250	50	7250	33	4785	125	18125	125	18125	100	14500
1	VEP21P**	47	6815	47	6815	30	4350	120	17400	120	17400	80	11600
1-1/2	VEP30P**	40	5800	40	5800	27	3915	110	15950	110	15950	80	11600
2	VEP45P	35	5075	35	5075	27	3915	110	15950	110	15950	80	11600

Size	Series/Size	Max. residual pressure during connection						Max. residual pressure during disconnection	
		Male, female to drain		Female, male to drain		Male and Female		MPa	psi
Inch		MPa	psi	MPa	psi	MPa	psi	MPa	psi
1/4	VEP7	30	4350	30	4350	25	3625	25	3625
3/8	VEP9P	25	3625	25	3625	25	3625	25	3625
1/2	VEP13P	25	3625	25	3625	20	2900	20	2900
5/8	VEP15P**	25	3625	25	3625	20	2900	20	2900
3/4	VEP17P**	25	3625	25	3625	15	2175	15	2175
1	VEP21P**	25	3625	25	3625	15	2175	15	2175
1-1/2	VEP30P**	25	3625	25	3625	5	725	5	725
2	VEP45P	25	3625	20	2900	2	290	2	290

* Spillage is an indicative value of the fluid loss during disconnection (according to ISO norm test method). The torque will increase as internal residual pressure increases.

** Specific dimensions of Stucchi VEP-P series are certified with Lloyd Type Approval in accordance with API 16D at specific rating pressure of 345 bar/5000 PSI. For complete technical information please contact Stucchi Technical Support.

Note:

VEP7 has metal to metal sealing system in the internal valve of male and in the valve of female coupling. Different male thread are available upon request. VEP45P is available with flange port and flange head connection configuration (code 62) upon request. For complete technical information please contact Stucchi Technical Support.

Different possible configurations:

Different threads available upon request.

Temperature range:

Standard seals NBR, PUR, POM from -20 °C to +100 °C (from -4 °F to +212 °F). Please read carefully Instructions and warnings for proper selection of the products.

Tests performed:

The couplings have been tested at max. operating pressure for 100.000 impulses in according to ISO norm.
The VEP45P coupled and male have been tested for 1.000.000 impulses.

Connection and disconnection with residual pressure in both couplings is recommended for occasional operations only.

For ordinary operations it is suggested to release pressure in one side before to connect and disconnect in way that operator effort and wearing of the couplings are reduced.

OVERALL DIMENSIONS

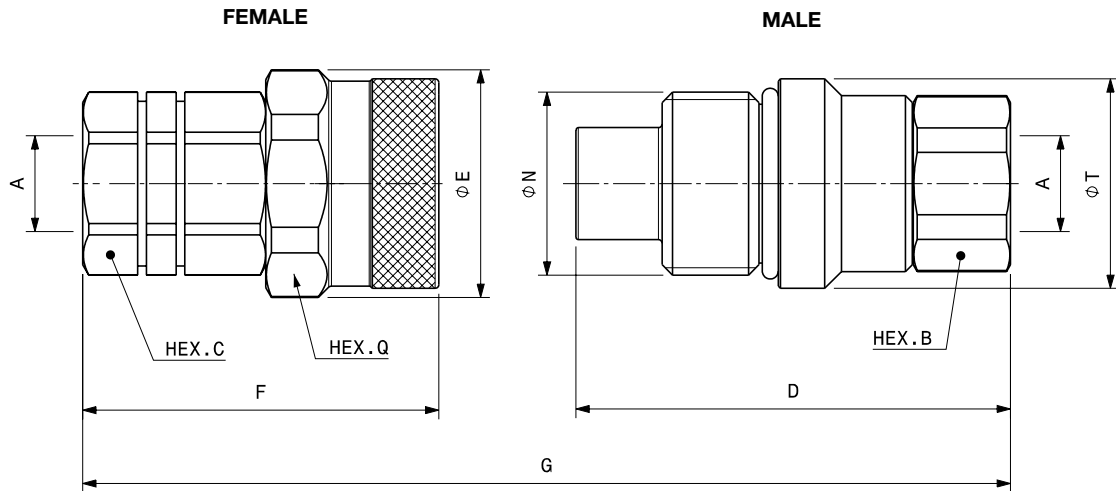

Port description: FEMALE THREAD BSPP (ISO 1179-1)

BODY SIZE	Descriptive Code	Item Code	PORT (A)	N	Overall Length	Length		Hex		Hex		Diameter		Weight							
						mm	inch	mm	inch	mm	inch	mm	inch	mm	inch	Kg	Lbs				
1/4"	F VEP7 1/4 BSP	Female 806500008	1/4"	M30x2	G	113,3	4,46	F	54,1	2,13	C	27,0	1,06	Q	36,0	1,42	E	38,8	1,53	0,25	0,55
	M VEP7 1/4 BSP	Male 806500009						D	71,0	2,80	B	22,0	0,87	T	34,8	1,37	0,23	0,51			
3/8"	F VEP9P 3/8 BSP	Female 807200002	3/8"	M33x2	G	131,3	5,17	F	65,8	2,59	C	30,0	1,18	Q	38,0	1,50	E	41,8	1,65	0,33	0,73
	M VEP9P 3/8 BSP	Male 807200003						D	82,5	3,25	B	27,0	1,06	T	37,8	1,49	0,33	0,72			
3/8"	F VEP9P 1/2 BSP	Female 807200004	1/2"	M33x2	G	138,8	5,46	F	70,8	2,79	C	30,0	1,18	Q	38,0	1,50	E	41,8	1,65	0,34	0,75
	M VEP9P 1/2 BSP	Male 807200005						D	85,0	3,35	B	27,0	1,06	T	37,8	1,49	0,32	0,71			
1/2"	F VEP13P 1/2 BSP	Female 807200006	1/2"	M40x3	G	154,6	6,09	F	77,8	3,06	C	36,0	1,42	Q	46,0	1,81	E	49,8	1,96	0,62	1,36
	M VEP13P 1/2 BSP	Male 807200007						D	95,0	3,74	B	36,0	1,42	T	45,8	1,80	0,60	1,32			
1/2"	F VEP13P 3/4 BSP	Female 807200008	3/4"	M40x3	G	164,0	6,46	F	84,8	3,34	C	36,0	1,42	Q	46,0	1,81	E	49,8	1,96	0,59	1,30
	M VEP13P 3/4 BSP	Male 807200009						D	97,4	3,83	B	36,0	1,42	T	45,8	1,80	0,58	1,28			
5/8"	F VEP15P 3/4 BSP	Female 807200010	3/4"	M45x3	G	165,4	6,51	F	84,9	3,34	C	41,0	1,61	Q	50,0	1,97	E	53,8	2,12	0,76	1,68
	M VEP15P 3/4 BSP	Male 807200011						D	99,0	3,90	B	36,0	1,42	T	49,8	1,96	0,67	1,48			
3/4"	F VEP17P 3/4 BSP	Female 807200024	3/4"	M50x3	G	188,5	7,42	F	97,7	3,85	C	46,0	1,81	Q	55,0	2,17	E	58,8	2,31	1,16	0,05
	M VEP17P 3/4 BSP	Male 807200025						D	113,6	4,47	B	46,0	1,81	T	54,8	2,16	1,13	0,04			
3/4"	F VEP17P 1 BSP	Female 807200012	1"	M50x3	G	190,5	7,50	F	99,7	3,93	C	46,0	1,81	Q	55,0	2,17	E	58,8	2,31	1,12	2,46
	M VEP17P 1 BSP	Male 807200013						D	113,6	4,47	B	46,0	1,81	T	54,8	2,16	1,02	2,24			
1"	F VEP21P 1 BSP	Female 807200020	1"	M58x3	G	205,2	8,08	F	105,8	4,17	C	55,0	2,17	Q	65,0	2,56	E	69,8	2,75	1,78	3,92
	M VEP21P 1 BSP	Male 807200021						D	123,4	4,86	B	55,0	2,17	T	64,5	2,54	1,54	3,40			
1"	F VEP21P 1-1/4 BSP	Female 807200014	1-1/4"	M58x3	G	206,2	8,12	F	106,8	4,20	C	55,0	2,17	Q	65,0	2,56	E	69,8	2,75	1,69	3,71
	M VEP21P 1-1/4 BSP	Male 807200015						D	123,4	4,86	B	55,0	2,17	T	64,5	2,54	1,44	3,17			
1-1/2"	F VEP30P 1-1/4 BSP	Female 807200022	1-1/4"	80x4 TpF	G	253,9	10,00	F	133,5	5,26	C	65,0	2,56	Q	85,0	3,35	E	92,0	3,62	3,88	8,55
	M VEP30P 1-1/4 BSP	Male 807200023						D	150,0	5,91	B	65,0	2,56	T	89,8	3,54	3,25	7,15			
1-1/2"	F VEP30P 1-1/2 BSP	Female 807200016	1-1/2"	80x4 TpF	G	253,9	10,00	F	133,5	5,26	C	65,0	2,56	Q	85,0	3,35	E	92,0	3,62	3,81	8,40
	M VEP30P 1-1/2 BSP	Male 807200017						D	150,0	5,91	B	65,0	2,56	T	89,8	3,54	3,20	7,05			
2"	F VEP45P 2 BSP	Female 807200018	2"	M130x6	G	383,5	15,10	F	224,8	8,85	C	90,0	3,54	Q	-	-	E	200,0	7,87	14,68	32,36
	M VEP45P 2 BSP	Male 807200019						D	218,4	8,60	B	90,0	3,54	T	145,0	5,71	11,89	26,20			

⚠ WARNING

A defect, a wrong choice or an improper use of products, can cause injury to persons, animals and objects. Connect under pressure products are suitable to be connected under residual (static) pressure. Never connect or disconnect with dynamic pressure (e.g. pump on). Do not use the female coupling disconnected with high impulse pressure. Do not couple-uncouple with flow in the circuit. Do not couple-uncouple when the temperature inside of the circuit is higher than 80 °C (176 °F). Check the maximum allowable working pressure of the port in use. It is important to limit contamination in the circuit to avoid compromising the function of the internal valves. Make sure that the medium used is compatible with seal and material as indicated for each series. In case of doubt please contact Stucchi Technical Support. The interchangeability is mentioned under the assumption that the manufacturer of the considered products has not changed any dimension. **It is mandatory to carefully read and closely follow the instructions before selecting or using any Stucchi products.** Always refer to the version uploaded in the Instructions and warning section of stucchigroup.com website for the latest release. For specific, product-related, instructions, please contact Stucchi technical service.

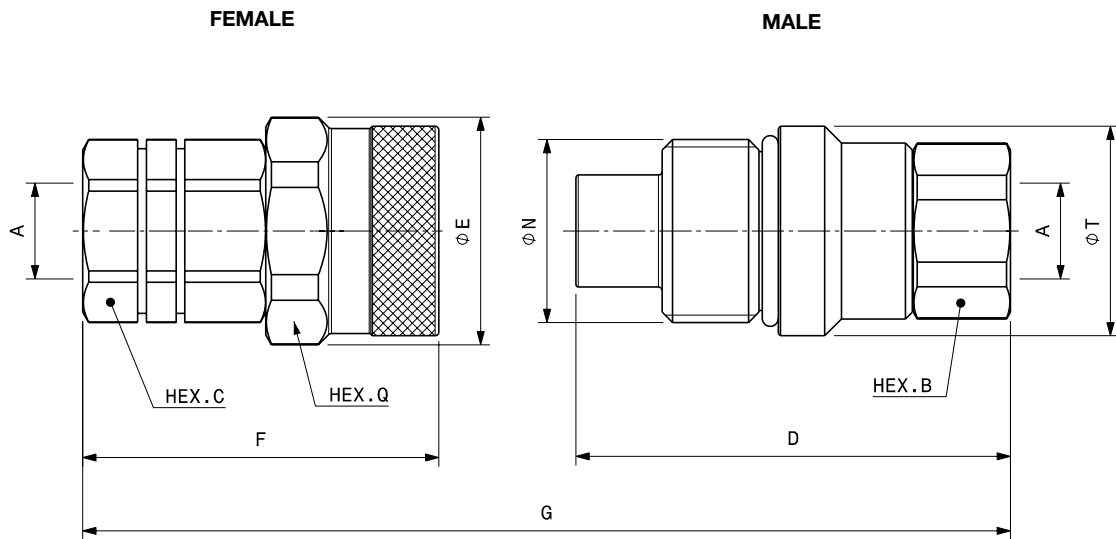

Port description: FEMALE THREAD NPT (ANSI B.1.20.1)

BODY SIZE	Descriptive Code	Item Code	PORT (A)	N	Overall Length	Length		Hex		Hex		Diameter		Weight							
						mm	inch	mm	inch	mm	inch	mm	inch	mm	inch	Kg	Lbs				
1/4"	F VEP7 1/4 NPT	Female 806501008	1/4"	M30x2	G	113,3	4,46	F	54,1	2,13	C	27,0	1,06	Q	36,0	1,42	E	38,8	1,53	0,25	0,55
	M VEP7 1/4 NPT	Male 806501009						D	71,0	2,80	B	22,0	0,87	T	34,8	1,37	0,24	0,52			
3/8"	F VEP9P 3/8 NPT	Female 807201002	3/8"	M33x2	G	131,3	5,17	F	65,8	2,59	C	30,0	1,18	Q	38,0	1,50	E	41,8	1,65	0,34	0,74
	M VEP9P 3/8 NPT	Male 807201003						D	82,5	3,25	B	27,0	1,06	T	37,8	1,49	0,33	0,72			
3/8"	F VEP9P 1/2 NPT	Female 807201004	1/2"	M33x2	G	138,8	5,46	F	70,8	2,79	C	30,0	1,18	Q	38,0	1,50	E	41,8	1,65	0,35	0,76
	M VEP9P 1/2 NPT	Male 807201005						D	85,0	3,35	B	27,0	1,06	T	37,8	1,49	0,32	0,71			
1/2"	F VEP13P 1/2 NPT	Female 807201006	1/2"	M40x3	G	154,6	6,09	F	77,8	3,06	C	36,0	1,42	Q	46,0	1,81	E	49,8	1,96	0,64	1,40
	M VEP13P 1/2 NPT	Male 807201007						D	95,0	3,74	B	36,0	1,42	T	45,8	1,80	0,61	1,33			
1/2"	F VEP13P 3/4 NPT	Female 807201008	3/4"	M40x3	G	164,10	6,46	F	84,8	3,34	C	36,0	1,42	Q	46,0	1,81	E	49,8	1,96	0,65	1,43
	M VEP13P 3/4 NPT	Male 807201009						D	97,5	3,84	B	36,0	1,42	T	45,8	1,80	0,62	1,36			
5/8"	F VEP15P 3/4 NPT	Female 807201010	3/4"	M45x3	G	165,4	6,51	F	84,9	3,34	C	41,0	1,61	Q	50,0	1,97	E	53,8	2,12	0,77	1,69
	M VEP15P 3/4 NPT	Male 807201011						D	99,0	3,90	B	36,0	1,42	T	49,8	1,96	0,69	1,52			
3/4"	F VEP17P 1 NPT	Female 807201012	1"	M50x3	G	190,5	7,50	F	99,7	3,93	C	46,0	1,81	Q	55,0	2,17	E	58,8	2,31	1,12	2,46
	M VEP17P 1 NPT	Male 807201013						D	113,6	4,47	B	46,0	1,81	T	54,8	2,16	1,03	2,26			
1"	F VEP21P 1-1/4 NPT	Female 807201014	1-1/4"	M58x3	G	206,2	8,12	F	106,8	4,20	C	55,0	2,17	Q	65,0	2,56	E	69,8	2,75	1,70	3,75
	M VEP21P 1-1/4 NPT	Male 807201015						D	123,4	4,86	B	55,0	2,17	T	64,5	2,54	1,47	3,23			
1 1/2"	F VEP30P 1-1/2 NPT	Female 807201016	1-1/2"	80x4 TpF	G	253,9	10,00	F	133,5	5,26	C	65,0	2,56	Q	85,0	3,35	E	92,0	3,62	3,84	8,47
	M VEP30P 1-1/2 NPT	Male 807201017						D	150,0	5,91	B	65,0	2,56	T	89,8	3,54	3,18	7,01			
2"	F VEP45P 2 NPT	Female 807201018	2"	M130x6	G	383,5	15,10	F	224,8	8,85	C	90,0	3,54	Q	-	-	E	200,0	7,87	14,76	32,54
	M VEP45P 2 NPT	Male 807201019						D	218,4	8,60	B	90,0	3,54	T	145,0	5,71	11,67	25,73			

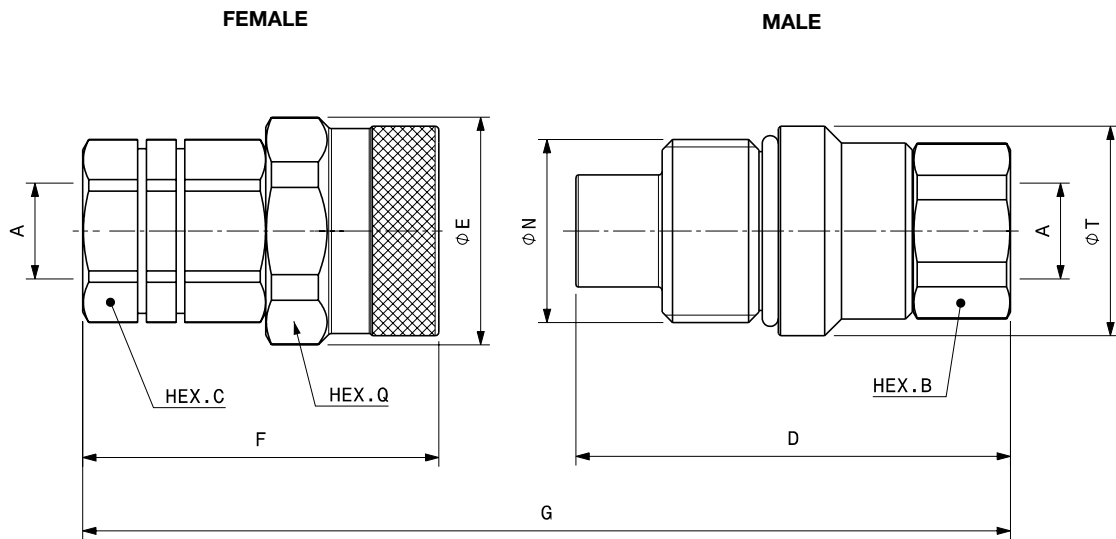

Port description: FEMALE THREAD SAE (ISO11926-1 & SAE J1926-1)

BODY SIZE	Descriptive Code	Item Code	PORT (A)	N	Overall Length	Length		Hex		Hex		Diameter		Weight							
						mm	inch	mm	inch	mm	inch	mm	inch	mm	inch	Kg	Lbs				
1/4"	F VEP7 3/8 SAE	Female 806504008	9/16-18UNF	M30x2	G	118,1	4,65	F	57,1	2,25	C	27,0	1,06	Q	36,0	1,42	E	38,8	1,53	0,25	0,55
	M VEP7 3/8 SAE	Male 806504009						D	72,8	2,87	B	22,0	0,87	T	34,8	1,37	0,23	0,51			
3/8"	F VEP9P 3/8 SAE	Female 807204000	9/16-18UNF	M33x2	G	132,5	5,22	F	65,8	2,59	C	30,0	1,18	Q	38,0	1,50	E	41,8	1,65	0,37	0,81
	M VEP9P 3/8 SAE	Male 807204001						D	83,7	3,30	B	27,0	1,06	T	37,8	1,49	0,35	0,77			
3/8"	F VEP9P 1/2 SAE	Female 807204002	3/4-16UNF	M33x2	G	140,8	5,54	F	70,8	2,79	C	30,0	1,18	Q	38,0	1,50	E	41,8	1,65	0,35	0,76
	M VEP9P 1/2 SAE	Male 807204003						D	87,0	3,43	B	27,0	1,06	T	37,8	1,49	0,33	0,73			
1/2"	F VEP13P 1/2 SAE	Female 807204006	3/4-16UNF	M40x3	G	160,10	6,30	F	77,8	3,06	C	36,0	1,42	Q	46,0	1,81	E	45,8	1,80	0,63	1,39
	M VEP13P 1/2 SAE	Male 807204007						D	100,5	3,96	B	36,0	1,42	T	45,8	1,80	0,67	1,48			
1/2"	F VEP13P 3/4 SAE	Female 807204008	1-1/16-12UNF	M40x3	G	167,0	6,57	F	84,8	3,34	C	36,0	1,42	Q	46,0	1,81	E	49,8	1,96	0,58	1,28
	M VEP13P 3/4 SAE	Male 807204009						D	100,4	3,95	B	36,0	1,42	T	45,8	1,80	0,59	1,29			
5/8"	F VEP15P 3/4 SAE	Female 807204010	1-1/16-12UNF	M45x3	G	168,4	6,63	F	84,9	3,34	C	41,0	1,61	Q	50,0	1,97	E	53,8	2,12	0,59	1,29
	M VEP15P 3/4 SAE	Male 807204011						D	102,0	4,02	B	36,0	1,42	T	49,8	1,96	0,68	1,49			
3/4"	F VEP17P 3/4 SAE	Female 807204022	1-1/16-12UNF	M50x3	G	192,5	7,58	F	99,7	3,93	C	46,0	1,81	Q	55,0	2,17	E	58,8	2,31	-	-
	M VEP17P 3/4 SAE	Male 807204023						D	115,6	4,55	B	46,0	1,81	T	54,8	2,16	1,14	2,51			
3/4"	F VEP17P 1 SAE	Female 807204012	1-5/16-12UNF	M50x3	G	190,5	7,50	F	99,7	3,93	C	46,0	1,81	Q	55,0	2,17	E	58,8	2,31	1,12	2,46
	M VEP17P 1 SAE	Male 807204013						D	113,6	4,47	B	46,0	1,81	T	54,8	2,16	1,01	2,23			
1"	F VEP21P 1 SAE	Female 807204024	1-5/16-12UNF	M58x3	G	207,2	8,16	F	105,8	4,17	C	55,0	2,17	Q	65,0	2,56	E	69,8	2,75	-	-
	M VEP21P 1 SAE	Male 807204025						D	125,4	4,94	B	55,0	2,17	T	64,5	2,54	-	-			
1"	F VEP21P 1-1/4 SAE	Female 807204014	1-5/8-12UNF	M58x3	G	206,2	8,12	F	106,8	4,20	C	55,0	2,17	Q	65,0	2,56	E	69,8	2,75	1,68	3,70
	M VEP21P 1-1/4 SAE	Male 807204015						D	123,4	4,86	B	55,0	2,17	T	64,5	2,54	1,46	3,22			
1-1/2"	F VEP30P 1-1/4 SAE	Female 807204026 *	1-5/8-12UNF	80x4 TpF	G	253,9	10,00	F	133,5	5,26	C	65,0	2,56	Q	85,0	3,35	E	92,0	3,62	-	-
	M VEP30P 1-1/4 SAE	Male 807204027 *						D	150,0	5,91	B	65,0	2,56	T	89,8	3,54	-	-			
1-1/2"	F VEP30P 1-1/2 SAE	Female 807204016	1-7/8-12UNF	80x4 TpF	G	253,9	10,00	F	133,5	5,26	C	65,0	2,56	Q	85,0	3,35	E	92,0	3,62	3,82	8,41
	M VEP30P 1-1/2 SAE	Male 807204017						D	150,0	5,91	B	65,0	2,56	T	89,8	3,54	3,16	6,96			
2"	F VEP45P 2 SAE	807204018	2-1/2-12UNF	M130x6	G	383,5	15,10	F	224,8	8,85	C	90,0	3,54	Q	-	-	E	200,0	7,87	14,60	32,19
	M VEP45P 2 SAE	807204019						D	218,4	8,60	B	90,0	3,54	T	145,0	5,71	12,18	25,85			

* Available upon request.

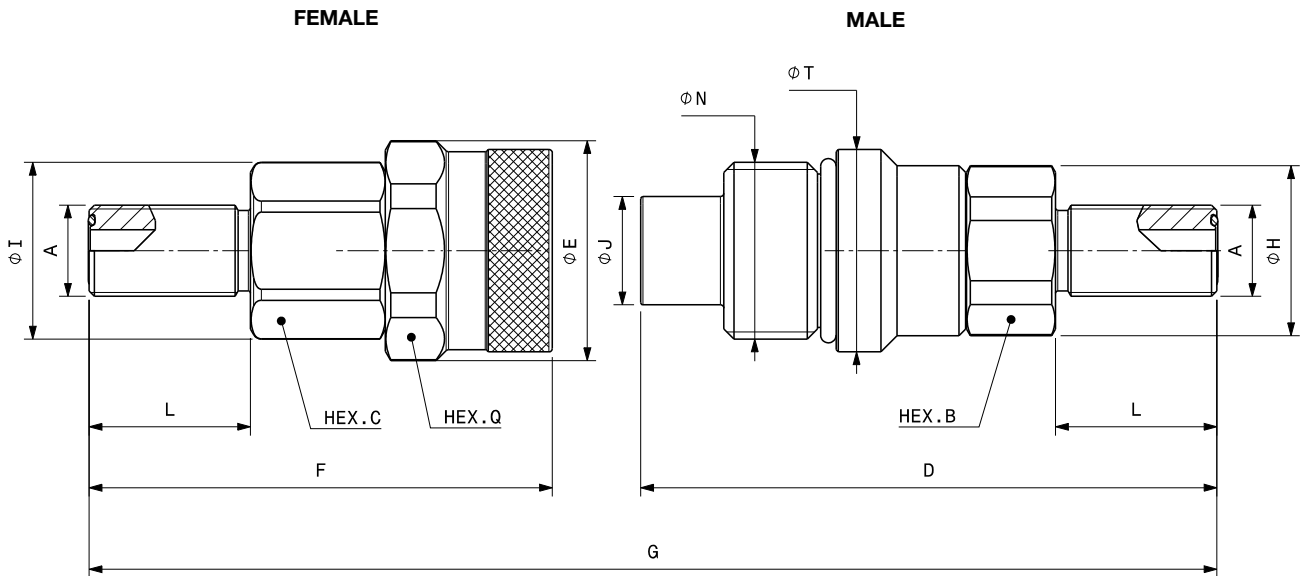

Port description: MALE THREAD ORFS/ORFS BULKHEAD (SAE J1453 or ISO 8434-3)

BODY SIZE	Descriptive Code	Item Code	PORT (A)	N	Overall Length	Length		L Port length		Hex		Hex		Diameter		Weight								
						mm	inch	mm	inch	mm	inch	mm	inch	mm	inch	Kg	Lbs							
3/8"	F VEP9P 3/8 ORFS	Female	807213002	11/16-16UN	M33x2	G	149,8	5,90	F	73,1	2,88	11	0,433	C	30,0	1,18	Q	38,0	1,50	E	41,8	1,65	0,35	0,77
	M VEP9P 3/8 ORFS	Male	807213003						D	93,7	3,69			B	27,0	1,06			T	37,8	1,49	0,36	0,79	
3/8"	F VEP9P 3/8 ORFS BH	Female	807213016	11/16-16UN	M33x2	G	195,8	7,71	F	96,1	3,78	34	1,339	C	30,0	1,18	Q	38,0	1,50	E	41,8	1,65	0,38	0,84
	M VEP9P 3/8 ORFS BH	Male	807213017						D	116,7	4,59			B	27,0	1,06			T	37,8	1,49	0,39	0,86	
1/2"	F VEP13P 1/2 ORFS	Female	807213004	13/16-16UN	M40x3	G	170,0	6,69	F	81,3	3,20	13	0,512	C	36,0	1,42	Q	46,0	1,81	E	49,8	1,96	0,64	1,41
	M VEP13P 1/2 ORFS	Male	807213005						D	106,9	4,21			B	36,0	1,42			T	45,8	1,80	0,65	1,43	
1/2"	F VEP13P 1/2 ORFS BH	Female	807213018	13/16-16UN	M40x3	G	217,0	8,54	F	104,8	4,13	36,5	1,437	C	36,0	1,42	Q	46,0	1,81	E	49,8	1,96	0,61	1,34
	M VEP13P 1/2 ORFS BH	Male	807213019						D	130,4	5,13			B	36,0	1,42			T	45,8	1,80	0,66	1,45	
5/8"	F VEP15P 3/4 ORFS	Female	807213006	1-3/16-12UN	M45x3	G	180,9	7,12	F	88,0	3,46	17	0,669	C	41,0	1,61	Q	50,0	1,97	E	53,8	2,12	0,73	1,61
	M VEP15P 3/4 ORFS	Male	807213007						D	111,4	4,39			B	36,0	1,42			T	49,8	1,96	0,74	1,63	
5/8"	F VEP15P 3/4 ORFS BH	Female	807213020	1-3/16-12UN	M45x3	G	229,9	9,05	F	112,5	4,43	41,5	1,634	C	41,0	1,61	Q	50,0	1,97	E	53,8	2,12	0,82	1,80
	M VEP15P 3/4 ORFS BH	Male	807213021						D	135,9	5,35			B	36,0	1,42			T	49,8	1,96	0,78	1,72	
3/4"	F VEP17P 1 ORFS	Female	807213008	1-7/16-12UN	M50x3	G	211,3	8,32	F	108,7	4,28	17,5	0,689	C	46,0	1,81	Q	55,0	2,17	E	58,8	2,31	1,19	2,62
	M VEP17P 1 ORFS	Male	807213009						D	125,4	4,94			B	46,0	1,81			T	54,8	2,16	1,11	2,44	
3/4"	F VEP17P 1 ORFS BH	Female	807213022	1-7/16-12UN	M50x3	G	260,5	10,26	F	133,4	5,25	42	1,654	C	46,0	1,81	Q	55,0	2,17	E	58,8	2,31	1,32	2,90
	M VEP17P 1 ORFS BH	Male	807213023						D	149,9	5,90			B	46,0	1,81			T	54,8	2,16	1,21	2,66	
1-1/2"	F VEP21P 1-1/4 ORFS	Female	807213010	1-11/16-12UN	M58x3	G	215,5	8,48	F	110,3	4,34	17,5	0,689	C	55,0	2,17	Q	65,0	2,56	E	69,8	2,75	1,73	3,81
	M VEP21P 1-1/4 ORFS	Male	807213011						D	129,2	5,09			B	55,0	2,17			T	64,5	2,54	1,51	3,32	
1-1/2"	F VEP21P 1-1/4 ORFS BH	Female	807213024	1-11/16-12UN	M58x3	G	264,5	10,41	F	134,8	5,31	42	1,654	C	55,0	2,17	Q	65,0	2,56	E	69,8	2,75	1,85	4,07
	M VEP21P 1-1/4 ORFS BH	Male	807213025						D	153,7	6,05			B	55,0	2,17			T	64,5	2,54	1,67	3,67	

Zinc Nickel version

VEP-P Series is available upon request also in Zinc Nickel version.

The Zinc Nickel plating ensures high resistance to corrosion and it is ideal for hydraulic equipment applications where an improved corrosion resistance is necessary.

For specific codes, configuration or any other information, please contact Stucchi Technical Support.





SPARE KIT SEAL FOR MALE

Repair kit / OR+BK+EXTERNAL OR		
Body Size	Description	Part Number
1/4"	M VEP7	815700735
3/8"	M VEP9P	815700736
1/2"	M VEP13P	815700737
5/8"	M VEP15P	815700738
3/4"	M VEP17P	815700739
1"	M VEP21P	815700740
1-1/2"	M VEP30P*	815700741
2"	M VEP45P	815700728

* OR + O-Ring holder

O-Ring in Nitrile
BackUp in Teflon®

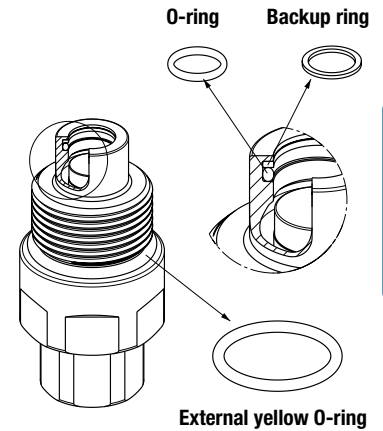

FLAT FACE SCREW

PROTECTIVE CAPS FOR VEP-P SERIES

Protective caps are always recommended to protect the couplings from damage, dirt inclusion, and will increase the product life. This is particularly important in mobile applications where exposure to weather and aggregate materials are common.

For VEP-P two solutions are available:

- threaded aluminum cap with lanyard (standard colors: natural aluminum, other colors available upon request)
- threaded plastic cap with lanyard (standard color black).

Caps and plugs are also available without lanyard, upon request.

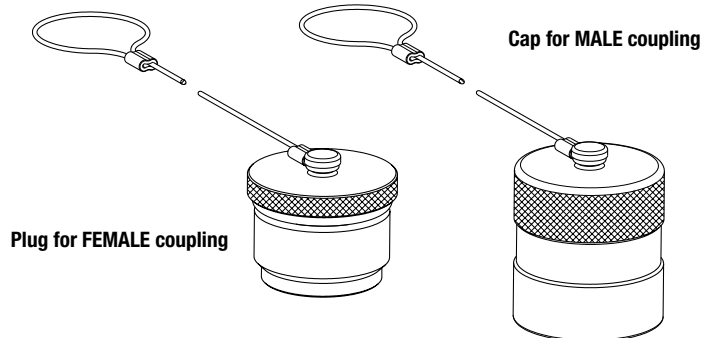

Body Size/Description	Protective Cap		Material/Color
	Part Number	Part Number	
	Plug for Female	Cap for Male	
1/4" VEP7	815305070	815305071	Aluminum/Natural
3/8" VEP9	815305072	815305073	Aluminum/Natural
1/2" VEP13	815305074	815305075	Aluminum/Natural
5/8" VEP15	815305076	815305077	Aluminum/Natural
3/4" VEP17	815305078	815305079	Aluminum/Natural
1" VEP21	815305080	815305081	Aluminum/Natural
1-1/2" VEP30	815305082	815305083	Aluminum/Natural
2" VEP45	815305042	815305043	Aluminum/Natural

Body Size/Description	Protective Cap		Material/Color
	Part Number	Part Number	
	Plug for Female	Cap for Male	
1/2" VEP13	815303128	815303129	Plastic/Black
5/8" VEP15	815303130	815303131	Plastic/Black
3/4" VEP17	815303132	815303133	Plastic/Black
1" VEP21	815303134	815303135	Plastic/Black
1-1/2" VEP30	815303136	815303137	Plastic/Black



VEP-HD SERIES

INTERCHANGE > Stucchi VEP profile



Easy CUP

BOP



TECHNICAL FEATURES AND OPTIONS

Interchange Stucchi VEP profile	Sealing description Nitrile NBR	Connection system Screw HDL version= lock system
Available sizes from 5/8" to 1-1/2"	Material/treatment Carbon steel /QPQ (Zn-Ni size 25)	Available threads BSP - NPT - SAE - FLANGE
Operating pressure Up to 550 bar	Locking mechanism Screw to connect	Flow rate Up to 750 l/min
Temperature (°C) -20° / +100°	Valving style Flat Face	Connection under pressure Connection: Both side (see Benefits). Disconnection: Allowed (see Benefits).

BENEFITS

- Easy connection/disconnection with both side under residual pressure thanks to the Stucchi design.
- Flat face is easy to clean, reducing the inclusion of contamination inside the hydraulic circuit.
- AVEP15HD, VEP17HD, VEP21HD and VEP30HD are certified with Lloyd Type Approval in accordance with API 16D at specific rating pressure of 345 bar/5000 psi. For complete technical information please contact Stucchi Technical Support.
- Minimal fluid spillage during disconnection, reducing fluid spillage to the environment.
- Minimal air inclusion during connection.
- Internal valve design creates minimal pressure drop, maintaining circuit efficiency in the system
- Internal pressure release valve system allows an easy connection with high internal residual pressure.
- The modular design allows flexibility with a wide range of configurations.
- High resistance to pressure impulses.
- Safe and simple to use.
- HDL version= lock system included.

HOW TO USE

- Before to connect, clean the mating surface of the couplings to avoid dirt inclusion in the circuit.
- To connect pull forward the connection sleeve of the female coupling.
- Align the female and male coupling holding forward the connection sleeve and thread together turning the sleeve.
- Keep couplers aligned during connection process. Do not push to connect couplings.
- The screwing of the threads should be done by hand without the use of the tools for the first part of the connection.
- The use of tools for the second part of connection can be necessary if there is high residual pressure in the circuit.
- Screw the connecting sleeve of the female until metal surface contact with the male coupling is complete.
- Tighten the sleeve to the base of the male using the tightening torque spec. as indicated in the table below.
- To disconnect turn sleeve from contact position using a wrench, then unscrew making sure the couplings stay aligned through the entire process.
- HDL version: in addition to the instructions here above remove external yellow O-ring on the male. To connect: 1st step connect by hand till metal to metal contact; 2nd step use tool to reach proper Tightening torque as indicated in the specific table; 3rd step insert cotter pin.
- Provide an adequate maintenance of the parts (washing with clear water, lubricating and greasing the QPQ surface) to extend the life in corrosive environment.

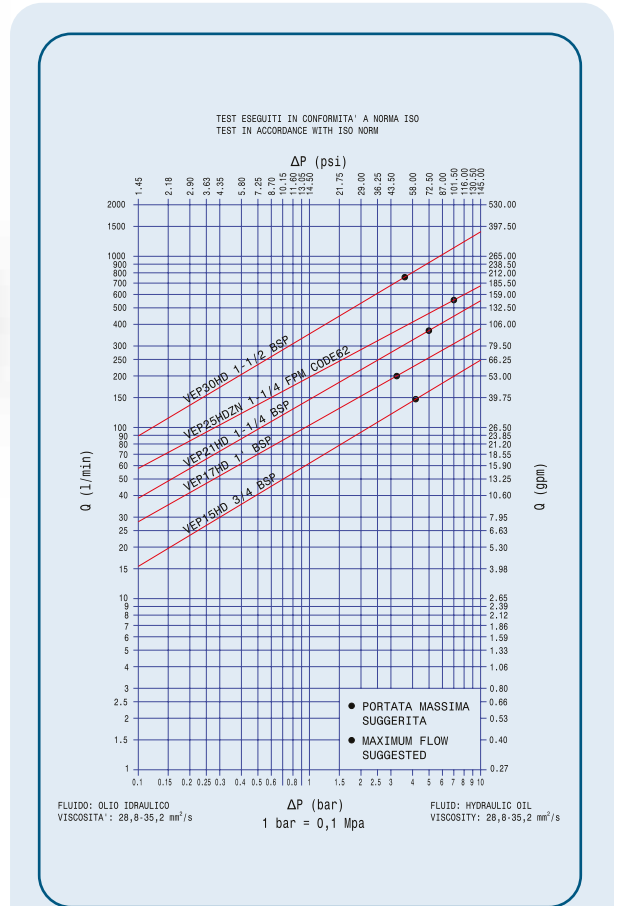

FLAT FACE SCREW

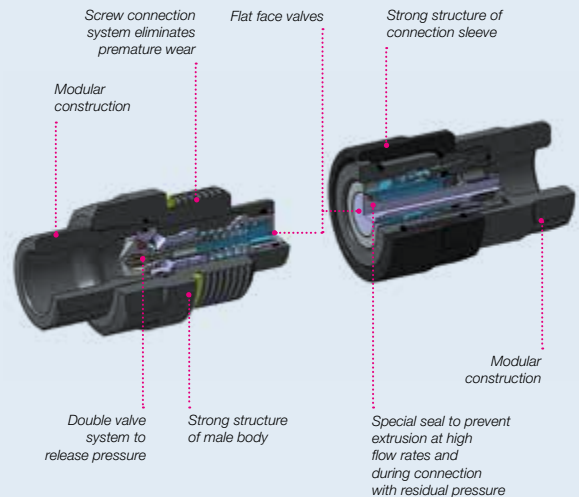

Size 25 has Zn-Ni as standard treatment

MAIN APPLICATIONS

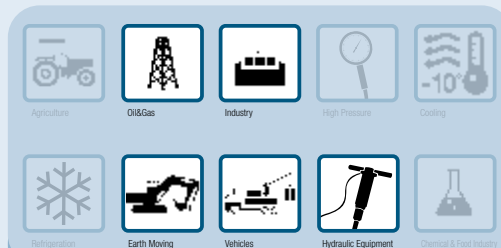

PERFORMANCES VEP-HD, VEP-HDL & VEP-HD FLANGE

Size	Series/Size	Max. flow suggested		Manual connect torque		Manual disconnect torque		Tightening torque		Spillage*
		l/min	gpm	Nm	lbf ft	Nm	lbf ft	Nm	lbf ft	
5/8	VEP15HD	148	39,22	3,0	2,21	1,8	1,33	70-80	52-59	0,03
3/4	VEP17HD	200	53,00	5,6	4,13	3,6	2,65	110-130	81-96	0,02
1	VEP21HD	378	100,17	8,2	6,04	5,8	4,27	125-145	92-107	0,06
1-1/4	VEP25HDZN	576	152,64	8,5	6,27	6,0	4,43	140-160	103-118	0,06
1-1/2	VEP30HD	750	198,75	26,0	19,16	12,5	9,21	155-175	114-129	0,20

PERFORMANCES VEP-HD & VEP-HDL

Size	Series/Size	Max. operating pressure						Burst pressure					
		Coupled		Male		Female		Coupled		Male		Female	
Inch		MPa	psi	MPa	psi	MPa	psi	MPa	psi	MPa	psi	MPa	psi
5/8	VEP15HD	55	7975	55	7975	33	4785	140	20300	140	20300	100	14500
3/4	VEP17HD	50	7250	50	7250	33	4785	125	18130	125	18130	100	14500
1	VEP21HD	47	6815	47	6815	30	4350	120	17400	120	17400	80	11600
1-1/4	VEP25HDZN	42	6090	42	6090	30	4350	120	17400	120	17400	80	11600
1-1/2	VEP30HD	40	5800	40	800	27	3915	110	15950	110	15950	80	11600

Size	Series/Size	Max. residual pressure during connection						Max. residual pressure during disconnection	
		Male, female to drain		Female, male to drain		Male and female		MPa	psi
Inch		MPa	psi	MPa	psi	MPa	psi	MPa	psi
5/8	VEP15HD	25	3625	25	3625	20	2900	20	2900
3/4	VEP17HD	25	3625	25	3625	15	2175	15	2175
1	VEP21HD	25	3625	25	3625	15	2175	15	2175
1-1/4	VEP25HDZN	25	3625	25	3625	5	725	5	2175
1-1/2	VEP30HD	25	3625	25	3625	5	725	5	725

PERFORMANCES VEP-HD & VEP-HDL FLANGE

Size	Series/Size	Max. operating pressure						Burst pressure					
		Coupled		Male		Female		Coupled		Male		Female	
Inch		MPa	psi	MPa	psi	MPa	psi	MPa	psi	MPa	psi	MPa	psi
3/4	VEP17HD FLANGE	42	6090	42	6090	33	4785	165	24000	165	24000	100	14500
1	VEP21HD FLANGE	42	6090	42	6090	30	4350	165	24000	165	24000	80	11600
1-1/4	VEP25HDZN FLANGE	42	6090	42	6090	30	4350	165	24000	165	24000	80	11600
1-1/2	VEP30HD FLANGE	42	6090	42	6090	27	3915	165	24000	165	24000	80	11600

Size	Series/Size	Tightening torque		Max. residual pressure during connection						Max. residual pressure during disconnection	
		Nm	lbf ft	Male, female to drain		Female, male to drain		Male and female		MPa	psi
Inch		Nm	lbf ft	MPa	psi	MPa	psi	MPa	psi	MPa	psi
3/4	VEP17HD FLANGE	110-130	81-96	25	3625	25	3625	15	2175	15	2175
1	VEP21HD FLANGE	125-145	92-107	25	3625	25	3625	15	2175	15	2175
1-1/4	VEP25HDZN FLANGE	125-145	92-107	25	3625	25	3625	15	2175	15	2175
1-1/2	VEP30HD FLANGE	155-175	114-129	25	3625	25	3625	5	725	5	725

* Spillage is an indicative value of the fluid loss during disconnection (according to ISO norm test method). Connect torque and disconnect torque without residual pressure. The torque will increase as internal residual pressure increases.

Port configurations include internal female threads:

- BSP, NPT and SAE.
- CODE62 flange ports (ISO 6162-2 and SAE J518 interchangeable).

Two ports options are available:

FP "Flange Port" (4 bolt mating configuration).

FH "Flange Head" (head configuration and sealing groove).

VEP15HD, VEP17HD, VEP21HD and VEP30HD are certified with Lloyd Type Approval in accordance with API 16D at specific rating pressure of 345 bar/5000 psi. For complete technical information please contact Stucchi Technical Support.

Different possible configurations:

Zn-Ni treatment is a standard for VEP25HD and available upon request for the others size.

Different threads available upon request.

Temperature range:

Standard seals NBR, PUR, POM from -20 °C to +100 °C (from -4 °F to +212 °F). Please read carefully Instructions and warnings for proper selection of the products.

Tests:

The couplings have been tested in according to ISO norm.

The couplings coupled have been tested at max. operating pressure for 1.000.000 impulses (VEP15HD and VEP25HDZN 500.000 impulses).

The couplings uncoupled have been tested at max. operating pressure for 100.000 impulses.

Connection and disconnection with residual pressure in both couplings is recommended for occasional operations only.

For ordinary operations it is suggested to release pressure in one side before to connect and disconnect in way that operator effort and wearing of the couplings are reduced.

OVERALL DIMENSIONS

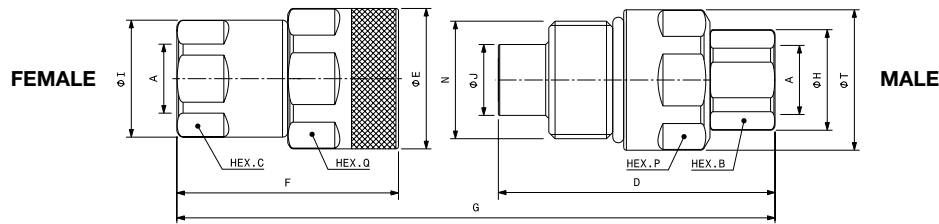

Port description: FEMALE THREAD BSPP (ISO 1179-1)

BODY SIZE	Descriptive Code	Item Code	PORT (A)	N	Overall Length	Length		Hex		Hex		Diameter		Weight							
						mm	inch	mm	inch	mm	inch	mm	inch	mm	inch	Kg	Lbs				
5/8"	F VEP15HD 3/4 BSP	Female 808100010	3/4"	M45x3	G	172,4	6,79	F	84,9	3,34	C	41,0	1,61	Q	50,0	1,97	E	53,8	2,12	0,92	2,03
	M VEP15HD 3/4 BSP	Male 808100011						D	106	4,17	B	36,0	1,42	P	50,0	1,97	T	53,8	2,12	0,94	2,07
3/4"	F VEP17HD 3/4 BSP	Female 808100018	3/4"	M50x3	G	200,9	7,91	F	99,7	3,93	C	46,0	1,81	Q	55,0	2,17	E	58,8	2,12	1,33	2,93
	M VEP17HD 3/4 BSP	Male 808100019						D	124,0	4,88	B	46,0	1,81	P	55,0	2,17	T	58,8	2,12	1,36	3,00
3/4"	F VEP17HD 1 BSP	Female 808100012	1"	M50x3	G	200,9	7,91	F	99,7	3,93	C	46,0	1,81	Q	55,0	2,17	E	58,8	2,31	1,28	2,82
	M VEP17HD 1 BSP	Male 808100013						D	124,0	4,88	B	46,0	1,81	P	55,0	2,17	T	58,8	2,31	1,30	2,87
1"	F VEP21HD 1 BSP	Female 808100020	1"	M58x3	G	216,2	8,51	F	106,8	4,20	C	55,0	2,17	Q	65,0	2,56	E	69,8	2,75	2,10	4,61
	M VEP21HD 1 BSP	Male 808100021						D	133,4	5,25	B	55,0	2,17	P	65,0	2,56	T	69,8	2,75	1,78	3,92
1"	F VEP21HD 1-1/4 BSP	Female 808100014	1-1/4"	M58x3	G	216,2	8,51	F	106,8	4,20	C	55,0	2,17	Q	65,0	2,56	E	69,8	2,75	2,02	4,45
	M VEP21HD 1-1/4 BSP	Male 808100015						D	133,4	5,25	B	55,0	2,17	P	65,0	2,56	T	69,8	2,75	1,79	3,95
1-1/4"	F VEP25HDZN 1-1/4 BSP	Female 812200010	1-1/4"	Rd68 x1/6	G	230,0	9,06	F	115,6	4,55	C	55,0	2,17	Q	75,0	2,95	E	80,0	3,15	2,68	5,91
	M VEP25HDZN 1-1/4 BSP	Male 812200011						D	141,8	5,58	B	65,0	2,56	P	70,0	2,76	T	80,0	3,15	2,44	5,38
1-1/2"	F VEP30HD 1-1/4 BSP	Female 808100022	1-1/4"	80x4 TpF	G	253,9	10,00	F	133,5	5,26	C	65,0	2,56	Q	85,0	3,35	E	95,0	3,74	4,40	9,69
	M VEP30HD 1-1/4 BSP	Male 808100023						D	150,0	5,91	B	65,0	2,56	P	75,0	2,95	T	82,5	3,25	3,36	7,39
1-1/2"	F VEP30HD 1-1/2 BSP	Female 808100016	1-1/2"	80x4 TpF	G	253,9	10,00	F	133,5	5,26	C	65,0	2,56	Q	85,0	3,35	E	95,0	3,74	4,36	9,61
	M VEP30HD 1-1/2 BSP	Male 808100017						D	150,0	5,91	B	65,0	2,56	P	75,0	2,95	T	94,4	3,72	3,30	7,28

Port description: FEMALE THREAD NPT (ANSI B.1.20.1)

BODY SIZE	Descriptive Code	Item Code	PORT (A)	N	Overall Length	Length		Hex		Hex		Diameter		Weight							
						mm	inch	mm	inch	mm	inch	mm	inch	mm	inch	Kg	Lbs				
5/8"	F VEP15HD 3/4 NPT	Female 808101010	3/4"	M45x3	G	172,4	6,79	F	84,9	3,34	C	41,0	1,61	Q	50,0	1,97	E	53,8	2,12	0,93	2,05
	M VEP15HD 3/4 NPT	Male 808101011						D	106	4,17	B	36,0	1,42	P	50,0	1,97	T	53,8	2,12	0,95	2,09
3/4"	F VEP17HD 3/4 NPT	Female 808101018	3/4"	M50x3	G	201,0	7,91	F	99,7	3,93	C	46,0	1,81	Q	55,0	2,17	E	58,8	2,31	1,34	2,95
	M VEP17HD 3/4 NPT	Male 808101019						D	124,1	4,89	B	46,0	1,81	P	55,0	2,17	T	58,8	2,31	1,42	3,13
3/4"	F VEP17HD 1 NPT	Female 808101012	1"	M50x3	G	200,9	7,91	F	99,7	3,93	C	46,0	1,81	Q	55,0	2,17	E	58,8	2,31	1,28	2,82
	M VEP17HD 1 NP	Male 808101013						D	124,0	4,88	B	46,0	1,81	P	55,0	2,17	T	58,8	2,31	1,30	2,87
1"	F VEP21HD 1 NPT	Female 808101020	1"	M58x3	G	216,2	8,51	F	106,8	4,20	C	55,0	2,17	Q	65,0	2,56	E	69,8	2,75	2,11	4,65
	M VEP21HD 1 NPT	Male 808101021						D	133,4	5,25	B	55,0	2,17	P	65,0	2,56	T	69,8	2,75	1,89	4,15
1"	F VEP21HD 1-1/4 NPT	Female 808101014	1-1/4"	M58x3	G	216,2	8,51	F	106,8	4,20	C	55,0	2,17	Q	65,0	2,56	E	69,8	2,75	2,02	4,45
	M VEP21HD 1-1/4 NPT	Male 808101015						D	133,4	5,25	B	55,0	2,17	P	65,0	2,56	T	69,8	2,75	1,79	3,95
1-1/4"	F VEP25HDZN 1-1/4 NPT	Female 812201058	1-1/4"	Rd68 x1/6	G	227,7	8,77	F	110,6	4,35	C	55,0	2,17	Q	75,0	2,95	E	80,0	3,15	2,68	5,91
	M VEP25HDZN 1-1/4 NPT	Male 812201059						D	139,5	5,49	B	65,0	2,56	P	70,0	2,76	T	80,0	3,15	2,44	5,38
1-1/2"	F VEP30HD 1-1/2 NPT	Female 808101016	1-1/2"	80x4 TpF	G	253,9	10,00	F	133,5	5,26	C	65,0	2,56	Q	85,0	3,35	E	95,0	3,74	4,36	9,61
	M VEP30HD 1-1/2 NPT	Male 808101017						D	150,0	5,91	B	65,0	2,56	P	75,0	2,95	T	94,4	3,72	3,30	7,28

Port description: FEMALE THREAD SAE (ISO 11926-1 & SAE J1926-1)

BODY SIZE	Descriptive Code	Item Code	PORT (A)	N	Overall Length	Length		Hex		Hex		Diameter		Weight							
						mm	inch	mm	inch	mm	inch	mm	inch	mm	inch	Kg	Lbs				
5/8"	F VEP15HD 3/4 SAE	Female 808104010	1-1/16-12UN	M45x3	G	172,4	6,79	F	84,9	3,34	C	41,0	1,61	Q	50,0	1,97	E	53,8	2,12	0,91	2,01
	M VEP15HD 3/4 SAE	Male 808104011						D	106	4,17	B	41,0	1,61	P	50,0	1,97	T	53,8	2,12	1,0	2,20
3/4"	F VEP17HD 1 SAE	Female 808104012	1-5/16-12UN	M50x3	G	201,9	7,95	F	100,7	3,96	C	46,0	1,81	Q	55,0	2,17	E	58,8	2,31	1,27	2,80
	M VEP17HD 1 SAE	Male 808104013						D	124,0	4,88	B	46,0	1,81	P	55,0	2,17	T	58,8	2,31	1,29	2,84
1"	F VEP21HD 1 SAE	Female 808104020	1-5/16-12UN	M58x3	G	216,2	8,51	F	106,8	4,20	C	55,0	2,17	Q	65,0	2,56	E	69,8	2,75	2,11	4,65
	M VEP21HD 1 SAE	Male 808104021						D	133,4	5,25	B	55,0	2,17	P	65,0	2,56	T	69,8	2,75	1,89	4,15
1"	F VEP21HD 1-1/4 SAE	Female 808104014	1-5/8-12UN	M58x3	G	216,2	8,51	F	106,8	4,20	C	55,0	2,17	Q	65,0	2,56	E	69,8	2,75	2,01	4,43
	M VEP21HD 1-1/4 SAE	Male 808104015						D	133,4	5,25	B	55,0	2,17	P	65,0	2,56	T	69,8	2,75	1,78	3,92
1-1/4"	F VEP25HDZN 1-1/4 SAE	Female 812204058	1-5/8-12UN-2B	Rd68 x1/6	G	227,7	8,77	F	110,6	4,35	C	55,0	2,17	Q	75,0	2,95	E	80,0	3,15	2,68	5,91
	M VEP25HDZN 1-1/4 SAE	Male 812204059						D	139,5	5,49	B	65,0	2,56	P	70,0	2,76	T	80,0	3,15	2,44	5,38
1-1/2"	F VEP30HD 1-1/4 SAE	Female 808104022	1-5/8-12UN-2B	80x4 TpF	G	253,9	10,00	F	133,5	5,26	C	65,0	2,56	Q	85,0	3,35	E	95,0	3,74	4,42	9,73
	M VEP30HD 1-1/4 SAE	Male 808104023						D	150,0	5,91	B	65,0	2,56	P	75,0	2,95	T	94,4	3,72	3,38	7,43
1-1/2"	F VEP30HD 1-1/2 SAE	Female 808104016	1-7/8-12UN	80x4 TpF	G	253,9	10,00	F	133,5	5,26	C	65,0	2,56	Q	85,0	3,35	E	95,0	3,74	4,34	9,56
	M VEP30HD 1-1/2 SAE	Male 808104017						D	150,0	5,91	B	65,0	2,56	P	75,0	2,95	T	94,4	3,72	3,28	7,23

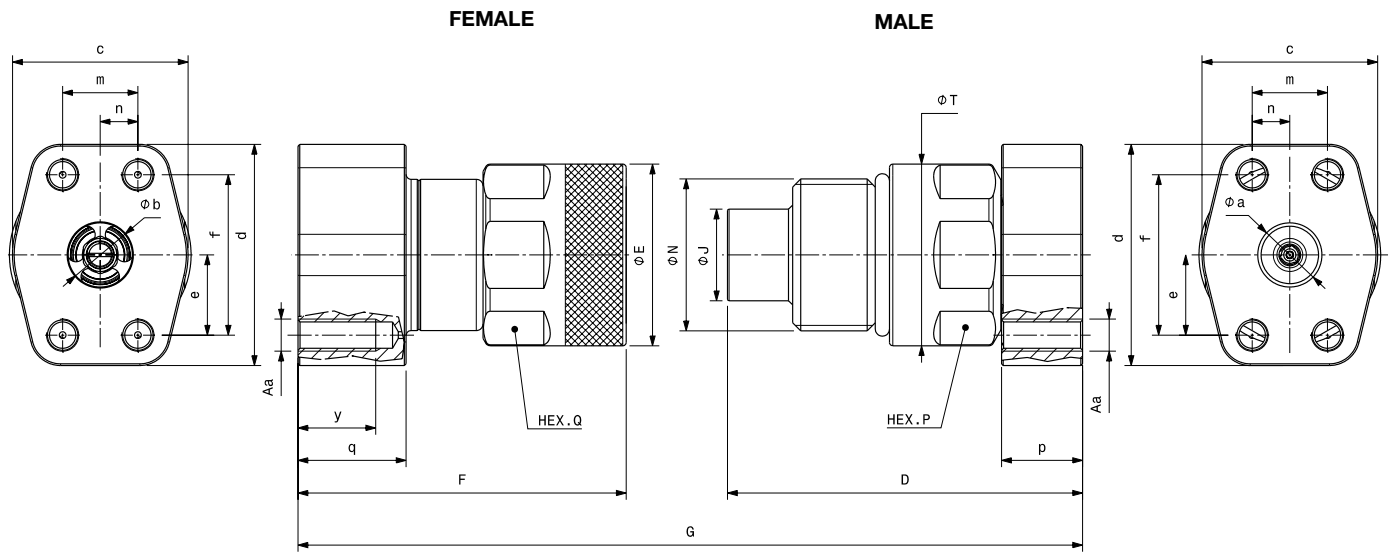

Port description: FLANGE PORT – 4 THREADED HOLES (ISO 6162-2 6000 psi & SAE J518)

BODY SIZE	Descriptive Code	Item Code		Diameter		N		Overall Length		Length		Hex		Diameter		Weight				
				mm	inch			mm	inch	mm	inch	mm	inch	mm	inch	mm	inch			
3/4"	F VEP17HD 1 FPU CODE 62	Female 808124020	b	22,5	0,89	M50x3	G	217,9	8,58	F	115,7	6,13	Q	55,0	2,16	E	58,8	2,31	1,68	3,70
	M VEP17HD 1 FPU CODE 62	Male 808124021	a	22,0	0,87					D	125,0	6,90	P	55,0	2,16	T	58,8	2,31	1,65	3,64
1"	F VEP21HD 1 FPM CODE62	Female 808124018	b	22,5	0,89	M58x3	G	228	8,98	F	116,8	4,6	Q	65,0	2,56	E	69,8	2,75	3,00	6,61
	M VEP21HD 1 FPM CODE62	Male 808124019	a	22,5	0,89					D	135,2	5,32	P	65,0	2,56	T	69,8	2,75	2,97	6,55
1"	F VEP21HD 1-1/4 FPM CODE62	Female 808124026	b	25,6	1,01	M58x3	G	228	8,98	F	116,8	4,6	Q	65,0	2,56	E	69,8	2,75	3,39	7,47
	M VEP21HD 1-1/4 FPM CODE62	Male 808124027	a	25,0	0,98					D	135,2	5,32	P	65,0	2,56	T	69,8	2,75	2,97	6,55
1"	F VEP21HD 1-1/4 FPU CODE62	Female 808124022	b	25,6	1,01	M58x3	G	215	8,46	F	115,8	6,72	Q	65,0	2,56	E	69,8	2,75	2,60	5,73
	M VEP21HD 1-1/4 FPU CODE62	Male 808124023	a	25,6	1,01					D	123,2	7,25	P	65,0	2,56	T	69,8	2,75	2,16	4,76
1-1/4"	F VEP25HDZN 1-1/4 FPM CODE62	Female 812224058	b	31,8	1,25	Rd68 x1/6	G	234,5	9,23	F	122,5	4,82	Q	37	1,46	E	80	3,15	3,72	8,20
	M VEP25HDZN 1-1/4 FPM CODE62	Male 812224059	a	31,8	1,25					D	139,4	5,49	P	35	1,38	T	80	3,15	3,28	7,23
1-1/4"	F VEP25HDZN 1-1/4 FPU CODE62	Female 812224060	b	31,8	1,25	Rd68 x1/6	G	234,5	9,23	F	122,5	4,82	Q	37	1,46	E	80	3,15	3,72	8,20
	M VEP25HDZN 1-1/4 FPU CODE62	Male 812224061	a	31,8	1,25					D	139,4	5,49	P	35	1,38	T	80	3,15	3,28	7,23
1-1/2"	F VEP30HD 1-1/4 FPM CODE62	Female 808124034	b	32,0	1,26	80x4 Tr	G	266,5	10,49	F	148,5	8,25	Q	85,0	3,35	E	95,0	3,74	5,23	11,53
	M VEP30HD 1-1/4 FPM CODE62	Male 808124035	a	32,0	1,26					D	147,6	8,33	P	75,0	2,95	T	94,4	3,72	3,85	8,49
1-1/2"	F VEP30HD 1-1/2 FPU CODE62	Female 808124024	b	35,0	1,38	80x4 Tr	G	276,6	10,89	F	156,6	6,17	Q	85,0	3,35	E	95,0	3,74	6,91	15,23
	M VEP30HD 1-1/2 FPU CODE62	Male 808124025	a	32,0	1,26					D	149,6	5,89	P	75,0	2,95	T	94,4	3,72	4,81	10,60
1-1/2"	F VEP30HD 1-1/2 FPM CODE62	Female 808124028	b	35,0	1,38	80x4 Tr	G	262,6	10,34	F	150,6	5,93	Q	85,0	3,35	E	95,0	3,74	6,91	15,23
	M VEP30HD 1-1/2 FPM CODE62	Male 808124029	a	32,0	1,26					D	141,6	5,57	P	75,0	2,95	T	94,4	3,72	4,81	10,60
1-1/2"	F VEP30HD 1-1/4 FPU CODE62	Female 808124036	b	32,0	1,26	TpF80x4	G	266,5	10,49	F	148,5	5,85	Q	85,0	3,35	E	95,0	3,74	5,91	13,02
	M VEP30HD 1-1/4 FPU CODE62	Male 808124037	a	32,0	1,26					D	147,6	5,81	P	75,0	2,95	T	94,4	3,72	4,17	9,19
1-1/2"	F VEP30HD 1-1/4 FPM CODE62 M12	Female 808124040	b	32,0	1,26	TpF80x4	G	266,5	10,49	F	148,5	5,85	Q	85,0	3,35	E	95,0	3,74	5,92	13,05
	M VEP30HD 1-1/4 FPM CODE62 M12	Male 808124041	a	32,0	1,26					D	147,6	5,81	P	75,0	2,95	T	94,4	3,72	4,18	9,22

Designation example VEP17HD1" FPU/M:

- VEP-HD (coupling series)
- 17 (size coupling Stucchi)
- 1" (size of flange)
- FP (Flange Port)
- U (flange threaded holes type UNC;
- M in case of metric threaded holes)
- CODE 62 (flanged coupling solution)

For complete technical information contact Stucchi via stucchigroup.com Contacts Form.

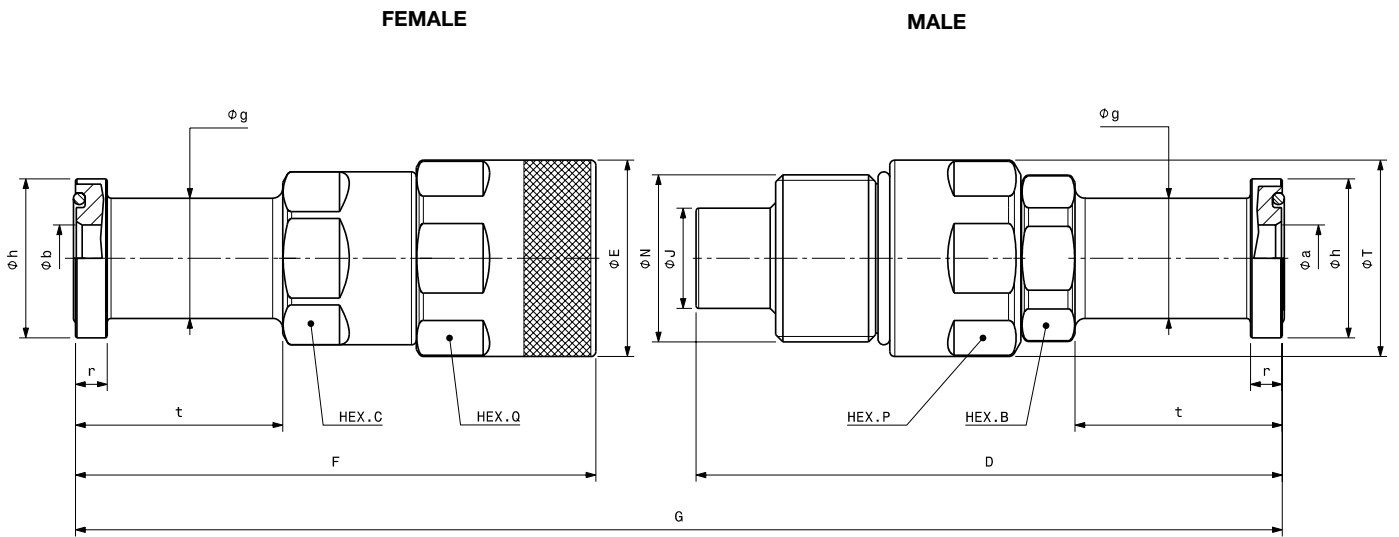
FLAT FACE SCREW
Port description: FLANGE HEAD – WITH O-RING (ISO 6162-2 6000 psi & SAE J518)

BODY SIZE	Descriptive Code	Item Code		Diameter		N	Overall Length		Length		Hex		Hex		Diameter		Weight						
				mm	inch		mm	inch	mm	inch	mm	inch	mm	inch	mm	inch	Kg	Lbs					
3/4"	F VEP17HD 1 FH CODE62	Female 808124012	b	20,0	0,79	M50x3	G	308,3	12,14	F	155,7	6,13	C	46,0	1,81	Q	55,0	2,16	E	58,8	2,31	1,68	3,70
	M VEP17HD 1 FH CODE62	Male 808124013	a	20,0	0,79					D	175,4	6,90	B	46,0	1,81	P	55,0	2,16	T	58,8	2,31	1,65	3,63
1"	F VEP21HD 1-1/4 FH CODE 62	Female 808124014	b	25,6	1,01	M58x3	G	331,0	13,03	F	170,8	6,72	C	55,0	2,16	Q	65,0	2,56	E	69,8	2,75	2,60	5,72
	M VEP21HD 1-1/4 FH CODE 62	Male 808124015	a	25,6	1,01					D	184,2	7,25	B	55,0	2,16	P	65,0	2,56	T	69,8	2,75	2,16	4,75
1-1/4"	F VEP25HDZN 1-1/4 CODE 62 FH	Female 812224062	b	31,6	1,24	Rd68 x1/6	G	385,1	15,16	F	219,1	8,63	C	55,0	2,16	Q	75,0	2,95	E	80,0	3,15	2,68	5,91
	M VEP25HDZN 1-1/4 CODE 62 FH	Male 812224063	a	31,6	1,24					D	193,4	7,61	B	65,0	2,56	P	70,0	2,76	T	80,0	3,15	2,82	6,22
1-1/2"	F VEP30HD 1-1/2 FH CODE 62	Female 808124016	b	32,0	1,26	TpF80x4	G	391,5	15,41	F	209,5	8,25	C	65,0	2,56	Q	85,0	3,35	E	95,0	3,74	5,23	11,51
	M VEP30HD 1-1/2 FH CODE 62	Male 808124017	a	32,0	1,26					D	211,6	8,33	B	65,0	2,56	P	75,0	2,95	T	94,4	3,72	3,85	8,47
1-1/2"	F VEP30HD 1-1/4 FH CODE62	Female 808124038	b	28,0	1,1	TpF80x4	G	171,5	6,75	F	199,5	7,85	-	-	-	Q	85,0	3,35	E	95,0	3,74	5,04	11,11
	M VEP30HD 1-1/4 FH CODE62	Male 808124039	a	28,0	1,1					D	201,6	7,94	-	-	-	P	75,0	2,95	T	94,4	3,72	3,66	8,07

Designation example VEP17HD1"FH:

- VEP-HD (coupling series)
- 17 (size coupling Stucchi)
- 1" (size of flange)
- FH (Flange Head)
- CODE 62 (flanged coupling solution)

 For complete technical information contact Stucchi via stucchigroup.com Contacts Form.

VEP-HDL version

VEP-HDL option is a female quick coupling interchangeable with standard VEP-HD series (flat face design, screw connection, connectable with residual pressure system), but equipped with special anti-unscrewing sleeve.

This series is suggested for specific heavy duty applications where the most severe pressure impulses are present, or else where you want to ensure that the operator successfully connect the male in the female coupling.

Female VEP-HDL version is interchangeable with male VEP-HD after removing yellow male external O-ring (upon request male without external O-ring).

Available size 5/8", 3/4", 1".

Tested at 420 bar for 500.000 impulses connected simulating a hoses rotation angle of 5 degrees.

For specific codes and configuration or any other information, please contact Stucchi Technical Support.



90° version

VEP-HD is available upon request also in special configuration with 90° fitting.

This version is ideal for applications with less space that requires a compact design and it guarantees the correct bending of the hose.

For specific codes, configuration or any other information, please contact Stucchi Technical Support.



WARNING

A defect, a wrong choice or an improper use of products, can cause injury to persons, animals and objects. Connect under pressure products are suitable to be connected under residual (static) pressure. Never connect or disconnect with dynamic pressure (e.g. pump on). Do not use the female coupling disconnected with high impulse pressure.

Do not couple-uncouple with flow in the circuit.

Do not couple-uncouple when the temperature inside of the circuit is higher than 80 °C (176 °F).

Check the maximum allowable working pressure of the port in use.

It is important to limit contamination in the circuit to avoid compromising the function of the internal valves.

Make sure that the medium used is compatible with seal and material as indicated for each series.

In case of doubt please contact Stucchi Technical Support.

The interchangeability is mentioned under the assumption that the manufacturer of the considered products has not changed any dimension.

It is mandatory to carefully read and closely follow the instructions before selecting or using any Stucchi products.

Always refer to the version uploaded in the Instructions and warning section of stucchigroup.com website for the latest release.

For specific, product-related, instructions, please contact Stucchi technical service.



SPARE KIT SEAL & KIT COTTER

Repair kit / OR+BK+EXTERNAL OR		
Body Size	Description	Part Number
5/8"	M VEP15HD	815700738
3/4"	M VEP17HD	815700739
1"	M VEP21HD	815700740
1-1/4"	M VEP25HD	815701275
1-1/2"	M VEP30HD*	815700741

*OR + O-Ring holder

O-Ring in Nitrile
BackUp in Teflon®

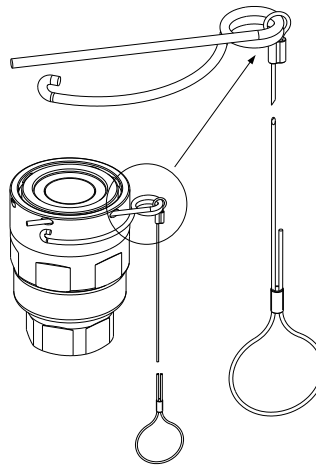

O-ring Backup ring

External yellow O-ring

Kit Cotter VEP-HDL version		
Body Size	Description	Part Number

Ask to sales department

PROTECTIVE CAPS FOR VEP-HD SERIES

Protective caps are always recommended to protect the couplings from damage, dirt inclusion, and will increase the product life. This is particularly important in mobile applications where exposure to weather and aggregate materials are common.

Two solutions are available.

- threaded aluminum caps with lanyard (standard colors: natural aluminum, other colors available upon request)
- threaded plastic caps with lanyard (standard color black).

Caps and plugs are also available without lanyard, upon request.

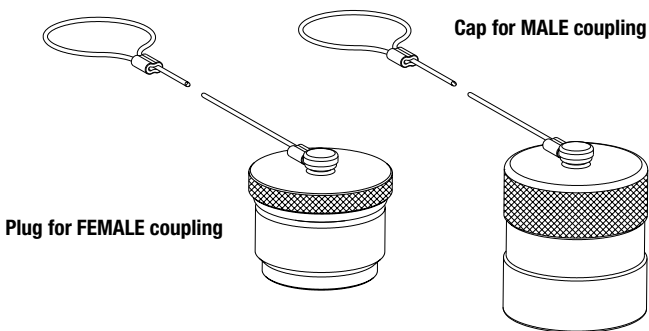

Protective Cap				
Body Size/Description :		Part Number		Material/Color
		Plug for Female	Cap for Male	
5/8"	VEP15	815305076	815305077	Aluminum/Natural
3/4"	VEP17	815305078	815305079	Aluminum/Natural
1"	VEP21	815305080	815305081	Aluminum/Natural
1-1/4"	VEP25	815305148	815305149	Aluminium/Natural
1-1/2"	VEP30	815305082	815305083	Aluminum/Natural

Protective Cap				
Body Size/Description :		Part Number		Material/Color
		Plug for Female	Cap for Male	
5/8"	VEP15	815303130	815303131	Plastic/Black
3/4"	VEP17	815303132	815303133	Plastic/Black
1"	VEP21	815303134	815303135	Plastic/Black
1-1/4"	VEP25	815303150	815303151	Plastic/Black
1-1/2"	VEP30	815303136	815303137	Plastic/Black



VP-P SERIES

INTERCHANGE > Stucchi profile



Easy CUP

BOP



TECHNICAL FEATURES AND OPTIONS

Interchange Stucchi profile	Sealing description Nitrile NBR	Connection system Screw
Available sizes from 1/4" to 1-1/2"	Material/treatment Carbon steel /Cr3+QPQ	Available threads BSP - NPT - SAE
Operating pressure Up to 600 bar	Locking mechanism Screw to connect + Safety sleeve	Flow rate Up to 750 l/min
Temperature (°C) -20° / +100°	Valving style Flat face	Connection under pressure Connection: Both side (see Benefits). Disconnection: Allowed (see Benefits).

BENEFITS

- Easy connection/disconnection with both side under residual pressure thanks to the Stucchi design.
- Flat face is easy to clean, reducing the inclusion of contamination inside the hydraulic circuit.
- Specific dimensions of Stucchi VP-P series are certified with Lloyd Type Approval in accordance with API 16D at specific rating pressure of 345 bar/5000 PSI.
- Minimal fluid spillage during disconnection, reducing fluid spillage to the environment.
- Minimal air inclusion during connection.
- Internal valve design creates minimal pressure drop, maintaining circuit efficiency in the system
- Internal pressure release valve system allows an easy connection with high internal residual pressure.
- The safety sleeve integrated in the connection system prevents the accidental disconnection.
- The modular design allows flexibility with a wide range of configurations.
- High resistance to pressure impulses.
- Safe and simple to use.

HOW TO USE

- Before to connect, clean the mating surface of the couplings to avoid dirt inclusion in the circuit.
- To connect align the female coupling to the male coupling, push the male and twist in one motion to catch the first thread on the female half and continue to thread together (do not push together couplers, screw only).
- The screwing of the threads should be done by hand without the use of the tools for the first part of the connection.
- Always connect male and female with the male adaptor fixed on the hose (male adaptor should not rotate during connection)
- The use of tools for the second part of connection can be necessary if there is high residual pressure in the circuit.
- Thread the mating halves until the sleeve lock clicks into position. This activates the safety lock and eliminates accidental disconnection of the coupling.
- To disconnect push the safety locking sleeve towards the male coupling and unthread the connection.
- The lock is disengaged after one complete rotation of the coupler, continue to unthread until both halves disconnect.
- If safety lock sleeve will not push back rotate the male coupling to couple direction until the sleeve will pull back.

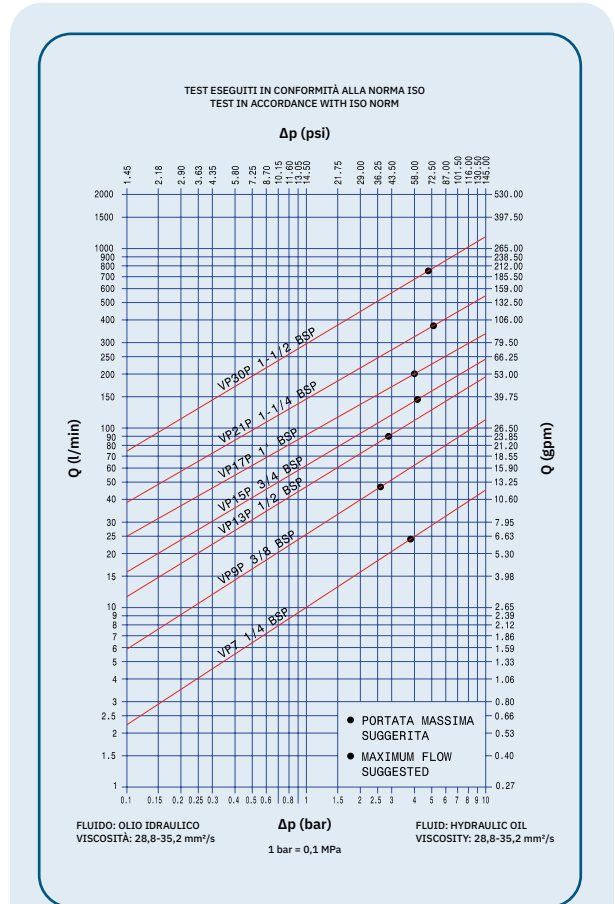

FLAT FACE SCREW

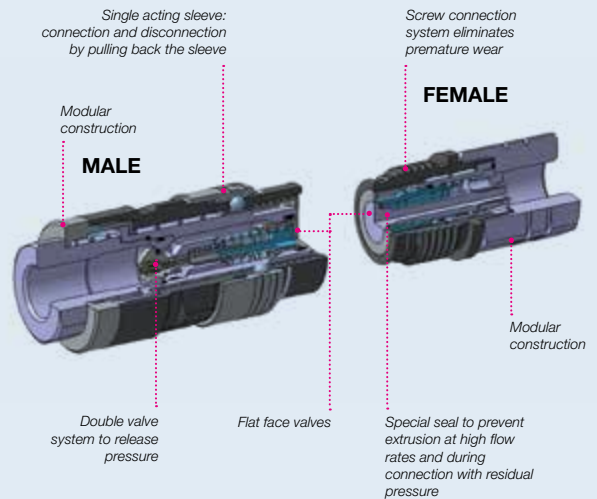

MAIN APPLICATIONS

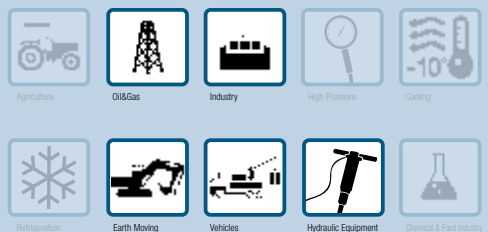

PERFORMANCES

Size	Series/Size	Max. flow suggested		Manual connect torque		Manual disconnect torque		Spillage*
		l/min	gpm	Nm	lbf ft	Nm	lbf ft	
1/4	VP7	24	6,36	0,6	0,44	0,4	0,29	0,01
3/8	VP9P	46	12,19	0,8	0,59	0,5	0,37	0,04
1/2	VP13P	90	23,85	1,1	0,81	1,0	0,74	0,02
5/8	VP15P**	148	39,22	1,1	0,81	1,0	0,74	0,03
3/4	VP17P**	200	53,00	2,0	1,47	1,4	1,03	0,01
1	VP21P**	378	100,17	2,2	1,62	1,8	1,33	0,06
1-1/2	VP30P**	750	198,75	6,5	4,79	3,2	2,36	0,20

Size	Series/Size	Max. operating pressure						Burst pressure					
		Coupled		Male		Female		Coupled		Male		Female	
Inch		MPa	psi	MPa	psi	MPa	psi	MPa	psi	MPa	psi	MPa	psi
1/4	VP7	60	8700	60	8700	42	6090	150	21750	150	21750	126	18270
3/8	VP9P	55	7975	55	7975	33	4785	140	20300	140	20300	100	14500
1/2	VP13P	55	7975	55	7975	33	4785	140	20300	140	20300	100	14500
5/8	VP15P**	55	7975	55	7975	33	4785	140	20300	140	20300	100	14500
3/4	VP17P**	50	7250	50	7250	33	4785	125	18125	125	18125	100	14500
1	VP21P**	47	6815	47	6815	30	4350	120	17400	120	17400	80	11600
1-1/2	VP30P**	40	5800	40	5800	27	3915	110	15950	110	15950	80	11600

Size	Series/Size	Max. residual pressure during connection						Max. residual pressure during disconnection	
		Male, female to drain		Female, male to drain		Male and female		MPa	psi
Inch		MPa	psi	MPa	psi	MPa	psi	MPa	psi
1/4	VP7	30	4350	25	3625	25	3625	25	3625
3/8	VP9P	25	3625	25	3625	25	3625	25	3625
1/2	VP13P	25	3625	25	3625	20	2900	20	2900
5/8	VP15P**	25	3625	25	3625	20	2900	20	2900
3/4	VP17P**	25	3625	25	3625	15	2175	15	2175
1	VP21P**	25	3625	25	3625	15	2175	15	2175
1-1/2	VP30P**	25	3625	25	3625	5	725	5	725

* Spillage is an indicative value of the fluid loss during disconnection (according to ISO norm test method)
Connect torque and disconnect torque without residual pressure.
The torque increase to increasing of internal residual pressure.

** Specific dimensions of Stucchi VP-P series are certified with Lloyd Type Approval in accordance with API 16D at specific rating pressure of 345 bar/5000 PSI. For complete technical information please contact Stucchi Technical Support.

Note:

VP7 has metal to metal sealing system in the internal valve of male and in the valve of female coupling.

Different possible configurations:

Different threads available upon request.

Temperature range:

Standard seals NBR, PUR, POM from -20 °C to +100 °C (from -4 °F to +212 °F).
Please read carefully Instructions and warnings for proper selection of the products.

Tests performed:

The couplings have been tested at max. operating pressure for 100.000 impulses according to ISO norm.

Connection and disconnection with residual pressure in both couplings is recommended for occasional operations only.

For ordinary operations it is suggested to release pressure in one side before to connect and disconnect in way that operator effort and wearing of the couplings are reduced.

⚠ WARNING

A defect, a wrong choice or an improper use of products, can cause injury to persons, animals and objects.
Connect under pressure products are suitable to be connected under residual (static) pressure.
Never connect or disconnect with dynamic pressure (e.g. pump on).
Do not use the female coupling disconnected with high impulse pressure.
Do not couple-uncouple with flow in the circuit.
Do not couple-uncouple when the temperature inside of the circuit is higher than 80 °C (176 °F).
Check the maximum allowable working pressure of the port in use.
It is important to limit contamination in the circuit to avoid compromising the function of the internal valves.
Make sure that the medium used is compatible with seal and material as indicated for each series.
In case of doubt please contact Stucchi Technical Support.
The interchangeability is mentioned under the assumption that the manufacturer of the considered products has not changed any dimension.
It is mandatory to carefully read and closely follow the instructions before selecting or using any Stucchi products.
Always refer to the version uploaded in the Instructions and warning section of stuchigroup.com website for the latest release.
For specific, product-related, instructions, please contact Stucchi technical service.

OVERALL DIMENSIONS

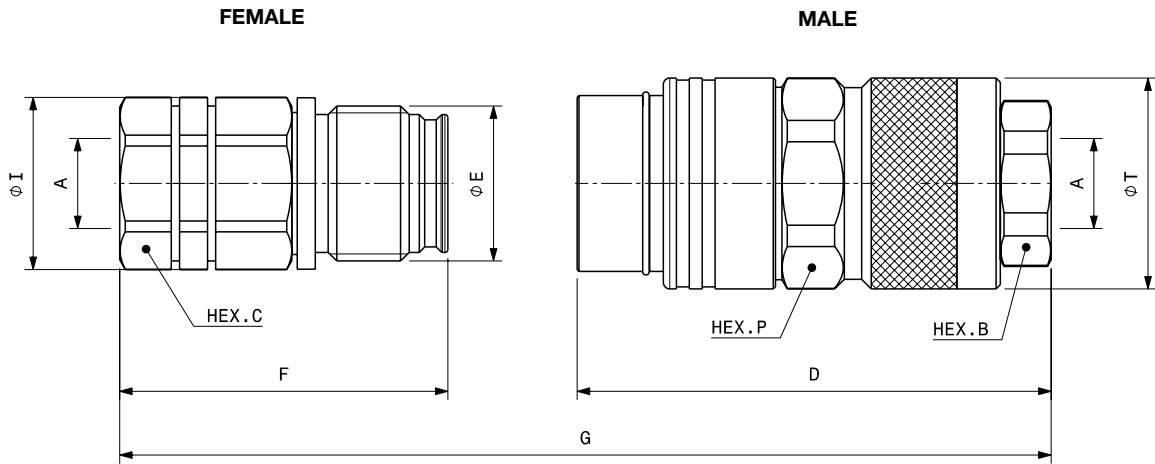

FLAT FACE SCREW

Port description: FEMALE THREAD BSPP (ISO 1179-1)

BODY SIZE	Descriptive Code	Item Code	PORT (A)	E	Overall Length		Length		Hex		Hex		Diameter		Weight			
					mm	inch	mm	inch	mm	inch	mm	inch	mm	inch	Kg	Lbs		
1/4"	F VP7 1/4 BSP	Female 801900000	1/4"	M24x2	G	125,2	4,93	F	52,8	2,08	C	27,0	1,06	I	29,0	1,14	0,16	0,35
	M VP7 1/4 BSP	Male 801900001						D	83,9	3,30	B	22,0	0,87	P	32,0	1,26	T	35,0
3/8"	F VP9P 3/8 BSP	Female 807300002	3/8"	M28x2	G	142,3	5,60	F	64,3	2,53	C	30,0	1,18	I	32,0	1,26	0,24	0,53
	M VP9P 3/8 BSP	Male 807300003						D	94,5	3,72	B	27,0	1,06	P	38,0	1,50	T	42,0
3/8"	F VP9P 1/2 BSP	Female 807300004	1/2"	M28x2	G	147,3	5,80	F	69,3	2,73	C	30,0	1,18	I	32,0	1,26	0,25	0,54
	M VP9P 1/2 BSP	Male 807300005						D	94,5	3,72	B	27,0	1,06	P	38,0	1,50	T	42,0
1/2"	F VP13P 1/2 BSP	Female 807300006	1/2"	M36x3	G	167,9	6,61	F	76,2	3,00	C	36,0	1,42	I	40,0	1,57	0,42	0,93
	M VP13P 1/2 BSP	Male 807300007						D	110,0	4,33	B	36,0	1,42	P	45,0	1,77	T	49,0
1/2"	F VP13P 3/4 BSP	Female 807300008	3/4"	M36x3	G	174,9	6,89	F	83,2	3,28	C	36,0	1,42	I	40,0	1,57	0,44	0,97
	M VP13P 3/4 BSP	Male 807300009						D	110,0	4,33	B	36,0	1,42	P	45,0	1,77	T	49,0
5/8"	F VP15P 3/4 BSP	Female 807300010	3/4"	M39x3	G	174,9	6,89	F	83,4	3,28	C	41,0	1,61	I	44,8	1,76	0,58	1,28
	M VP15P 3/4 BSP	Male 807300011						D	110,0	4,33	B	36,0	1,42	P	48,0	1,89	T	52,0
3/4"	F VP17P 3/4 BSP	Female 807300018	3/4"	M45x3	G	200,5	7,89	F	96,0	3,78	C	46,0	1,81	I	49,8	1,96	0,93	2,05
	M VP17P 3/4 BSP	Male 807300019						D	127,1	5,00	B	46,0	1,81	P	55,0	2,17	T	60,0
3/4"	F VP17P 1 BSP	Female 807300012	1"	M45x3	G	202,5	7,97	F	98,0	3,86	C	46,0	1,81	I	49,8	1,96	0,91	2,00
	M VP17P 1 BSP	Male 807300013						D	127,1	5,00	B	46,0	1,81	P	55,0	2,17	T	60,0
1"	F VP21P 1 BSP	Female 807300022	1"	M55x3	G	213,8	8,42	F	104,0	4,09	C	55,0	2,17	I	59,8	2,35	1,49	3,28
	M VP21P 1 BSP	Male 807300023						D	137,0	5,39	B	55,0	2,17	P	70,0	2,76	T	76,0
1"	F VP21P 1-1/4 BSP	Female 807300014	1-1/4"	M55x3	G	214,8	8,46	F	105,0	4,13	C	55,0	2,17	I	59,8	2,35	1,40	3,08
	M VP21P 1-1/4 BSP	Male 807300015						D	137,0	5,39	B	55,0	2,17	P	70,0	2,76	T	76,0
1-1/2"	F VP30P 1-1/4 BSP	Female 807300024	1-1/4"	M72x4	G	271,3	10,68	F	132,2	5,20	C	65,0	2,56	I	85,0	3,35	-	-
	M VP30P 1-1/4 BSP	Male 807300025						D	174,7	6,88	B	65,0	2,56	P	85,0	3,35	T	94,0
1-1/2"	F VP30P 1-1/2 BSP	Female 807300016	1-1/2"	M72x4	G	271,3	10,68	F	132,2	5,20	C	65,0	2,56	I	85,0	3,35	2,93	6,46
	M VP30P 1-1/2 BSP	Male 807300017						D	174,7	6,88	B	65,0	2,56	P	85,0	3,35	T	94,0

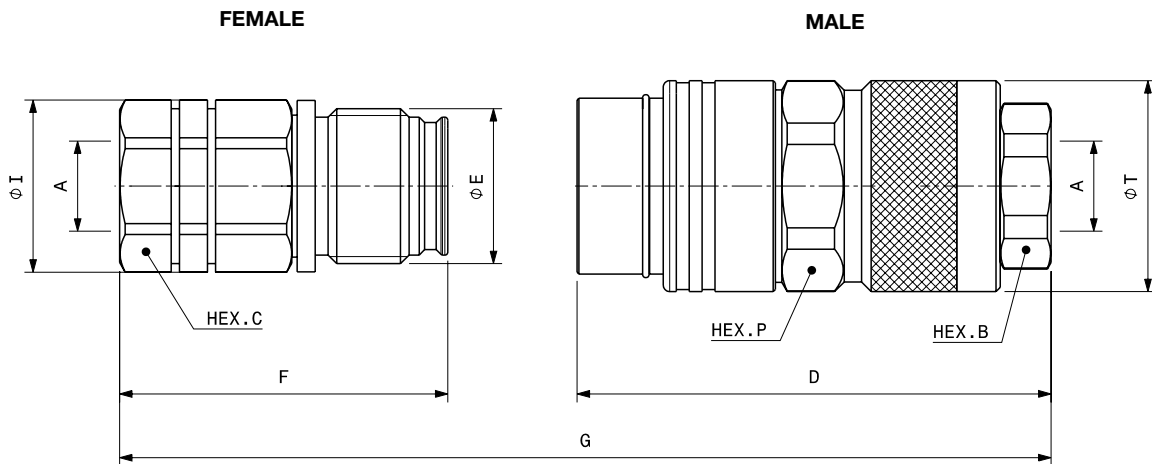

Port description: FEMALE THREAD NPT (ANSI B.1.20.1)

BODY SIZE	Descriptive Code	Item Code	PORT (A)	E	Overall Length		Length		Hex		Hex		Diameter		Weight			
					mm	inch	mm	inch	mm	inch	mm	inch	mm	inch	Kg	Lbs		
1/4"	F VP7 1/4 NPT	Female 801901004	1/4"	M24x2	G	126,6	4,98	F	52,8	2,08	C	27,0	1,06	I	29,0	1,14	0,17	0,36
	M VP7 1/4 NPT	Male 801901005						D	85,3	3,36	B	22,0	0,87	P	32,00	1,26	T	35,0
3/8"	F VP9P 3/8 NPT	Female 807301002	3/8"	M28x2	G	142,3	5,60	F	64,3	2,53	C	30,0	1,18	I	32,0	1,26	0,24	0,53
	M VP9P 3/8 NPT	Male 807301003						D	94,5	3,72	B	27,0	1,06	P	38,00	1,50	T	42,0
3/8"	F VP9P 1/2 NPT	Female 807301004	1/2"	M28x2	G	147,3	5,80	F	69,3	2,73	C	30,0	1,18	I	32,0	1,26	0,24	0,53
	M VP9P 1/2 NPT	Male 807301005						D	94,5	3,72	B	27,0	1,06	P	38,00	1,50	T	42,0
1/2"	F VP13P 1/2 NPT	Female 807301006	1/2"	M36x3	G	167,9	6,61	F	76,2	3,00	C	36,0	1,42	I	40,0	1,57	0,43	0,94
	M VP13P 1/2 NPT	Male 807301007						D	110,0	4,33	B	36,0	1,42	P	45,00	1,77	T	49,0
1/2"	F VP13P 3/4 NPT	Female 807301008	3/4"	M36x3	G	174,9	6,89	F	83,2	3,28	C	36,0	1,42	I	40,0	1,57	0,44	0,97
	M VP13P 3/4 NPT	Male 807301009						D	110,0	4,33	B	36,0	1,42	P	45,00	1,77	T	49,0
5/8"	F VP15P 3/4 NPT	Female 807301010	3/4"	M39x3	G	174,9	6,89	F	83,4	3,28	C	41,0	1,61	I	44,8	1,76	0,60	1,31
	M VP15P 3/4 NPT	Male 807301011						D	110,0	4,33	B	36,0	1,42	P	48,00	1,89	T	52,0
3/4"	F VP17P 1 NPT	Female 807301012	1	M45x3	G	202,5	7,97	F	98,0	3,86	C	46,0	1,81	I	49,8	1,96	0,92	2,02
	M VP17P 1 NPT	Male 807301013						D	127,1	5,00	B	46,0	1,81	P	55,00	2,17	T	60,0
1"	F VP21P 1-1/4 NPT	Female 807301014	1-1/4"	M55x3	G	218,1	8,59	F	108,3	4,26	C	55,0	2,17	I	59,8	2,35	1,43	3,15
	M VP21P 1-1/4 NPT	Male 807301015						D	137,0	5,39	B	55,0	2,17	P	70,00	2,76	T	76,0
1-1/2"	F VP30P 1-1/2 NPT	Female 807301016	1-1/2"	M72x4	G	271,3	10,68	F	132,2	5,20	C	65,0	2,56	I	85,0	3,35	2,93	6,46
	M VP30P 1-1/2 NPT	Male 807301017						D	174,7	6,88	B	65,0	2,56	P	85,00	3,35	T	94,0

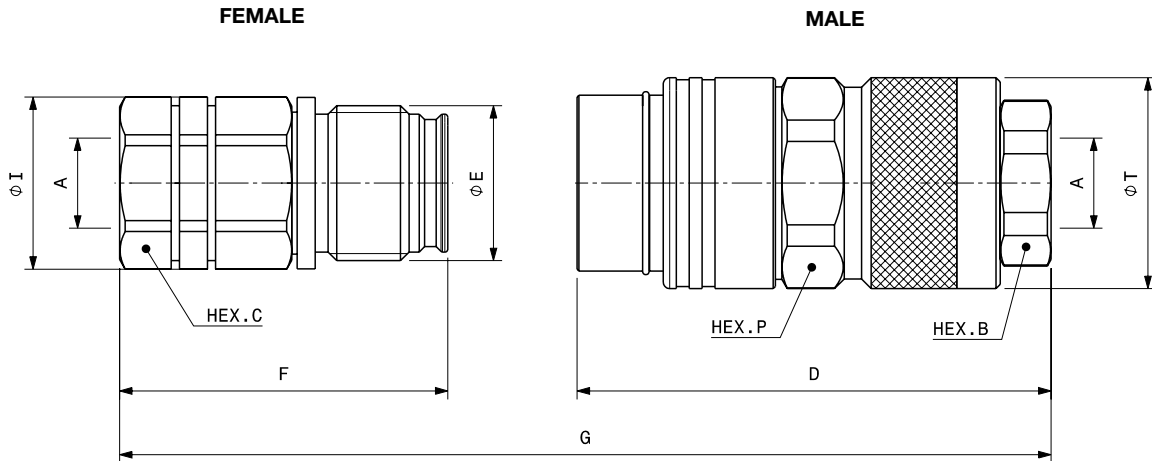

FLAT FACE SCREW

Port description: FEMALE THREAD SAE (ISO 11926-1 & SAE J1926-1)

BODY SIZE	Descriptive Code	Item Code	PORT (A)	E	Overall Length	Length		Hex		Hex		Diameter		Weight					
						mm	inch	mm	inch	mm	inch	mm	inch	Kg	Lbs				
3/8"	FVP9P 3/8 SAE	Female	807304020	9/16-18UNF	M28x2	G	142,3	5,60	F	64,3	2,53	C	30,0	1,18	I	32,0	1,26	0,25	0,54
	MVP9P 3/8 SAE	Male	807304021			D	94,5	3,72	B	27,0	1,06	P	38,00	1,50	T	42,0	1,65	0,60	1,32
1/2"	FVP13P 1/2 SAE	Female	807304022	3/4-16UNF	M36x3	G	169,9	6,69	F	76,2	3,00	C	36,00	1,42	I	40,0	1,57	0,43	0,95
	MVP13P 1/2 SAE	Male	807304023			D	110,0	4,33	B	36,00	1,42	P	45,00	1,77	T	49,0	1,93	0,93	2,05
1/2"	FVP13P 3/4 SAE	Female	807304008	1-1/16-12UN	M36x3	G	174,9	6,89	F	83,2	3,28	C	36,0	1,42	I	40,0	1,57	0,43	0,95
	MVP13P 3/4 SAE	Male	807304009			D	110,0	4,33	B	36,0	1,42	P	45,00	1,77	T	49,0	1,93	0,93	2,05
5/8"	FVP15P 3/4 SAE	Female	807304010	1-1/16-12UN	M39x3	G	174,9	6,89	F	83,4	3,28	C	41,0	1,61	I	44,8	1,76	0,58	1,27
	MVP15P 3/4 SAE	Male	807304011			D	110,0	4,33	B	36,0	1,42	P	48,00	1,89	T	52,0	2,05	1,05	2,30
3/4"	FVP17P 1 SAE	Female	807304012	1-5/16-12UN	M45x3	G	202,5	7,97	F	98,0	3,86	C	46,0	1,81	I	49,8	1,96	0,90	1,97
	MVP17P 1 SAE	Male	807304013			D	127,1	5,00	B	46,0	1,81	P	55,00	2,17	T	60,0	2,36	1,58	3,48
1"	FVP21P 1-1/4 SAE	Female	807304014	1-5/8-12UN	M55x3	G	214,8	8,46	F	105,0	4,13	C	55,0	2,17	I	59,8	2,35	1,40	3,09
	MVP21P 1-1/4 SAE	Male	807304015			D	137,0	5,39	B	55,0	2,17	P	70,00	2,76	T	76,0	2,99	2,50	5,51
1-1/2"	FVP30P 1-1/2 SAE	Female	807304016	1-7/8-12UN	M72x4	G	271,3	10,68	F	132,2	5,20	C	65,0	2,56	I	85,0	3,35	2,92	6,44
	MVP30P 1-1/2 SAE	Male	807304017			D	174,7	6,88	B	65,0	2,56	P	85,00	3,35	T	94,0	3,70	5,10	11,24



SPARE KIT SEAL FOR MALE

Repair kit / OR+BK		
Body Size	Description	Part Number
1/4"	M VP7	815700519
3/8"	M VP9P	815701096
1/2"	M VP13P	815700339
5/8"	M VP15P	815700341
3/4"	M VP17P	815700655
1"	M VP21P	815700345
1-1/2"	M VP30P*	815700697

* Kit replacement O-Ring Holder + O-Ring

O-Ring in NBR
BackUp in Teflon®

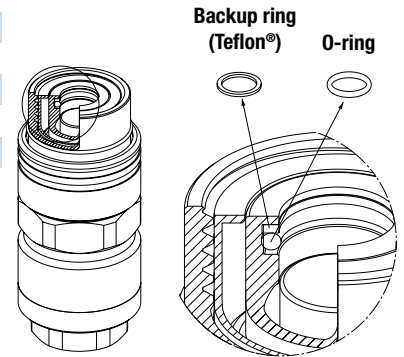

PROTECTIVE CAPS FOR VP-P SERIES

Protective caps are always recommended to protect the couplings from damage, dirt inclusion, and will increase the product life. This is particularly important in mobile applications where exposure to weather and aggregate materials are common.

For the VP-P series aluminum screw caps complete with lanyard are available (standard colors: natural aluminum, other colors available upon request).

Caps and plugs are also available without lanyard, upon request.

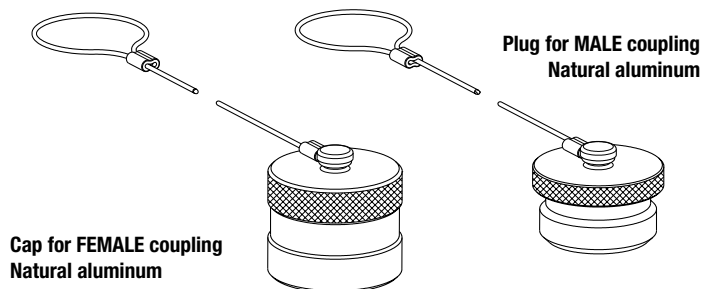

Body Size/Description	Protective Cap		Material/Color
	Cap for Female	Plug for Male	
1/4" VP7	815305050	815305051	Aluminum/Natural
3/8" VP9P	815305052	815305053	Aluminum/Natural
1/2" VP13P	815305054	815305055	Aluminum/Natural
5/8" VP15P	815305056	815305057	Aluminum/Natural
3/4" VP17P	815305058	815305059	Aluminum/Natural
1" VP21P	815305060	815305061	Aluminum/Natural
1-1/2" VP30P	815305062	815305063	Aluminum/Natural



Easy
CUP



SATURN

p. 99

Valving style: Flat face
Interchange: ISO 16028
Sealing description: Nitrile NBR
Available sizes: From 1/2" to 3/4"
Operating pressure: Up to 350 bar
Flow rate: Up to 200 l/min
Material / Treatment:
Carbon steel / Cr3
Connection under pressure:
One side only

Easy
CUP



SATURN HF p. 105

Valving style: Flat face
Interchange: ISO 16028
Sealing description: Nitrile NBR
Available sizes: From 1/2" to 3/4"
Operating pressure: Up to 350 bar
Flow rate: Up to 200 l/min
Material / Treatment:
Carbon steel / Cr3
Connection under pressure:
One side only



SATURN SERIES

INTERCHANGE > ISO 16028 (for the couplings)



Easy CUP



TECHNICAL FEATURES AND OPTIONS

Interchange ISO 16028 (for the couplings)	Sealing description Nitrile NBR	Connection system Push
Available sizes from 1/2" to 3/4"	Material/treatment Carbon steel /Cr3	Available threads SAE - JIC
Operating pressure Up to 350 bar	Locking mechanism Locking ball + Safety Lock	Flow rate Up to 200 l/min
Temperature (°C) -20° / +100°	Valving style Flat face	Connection under pressure Connection: One side - Both side if use with APM/AHD (see Benefits). Disconnection: Allowed (see Benefits).

BENEFITS

- Stucchi design pressure relief system completely independent of the connections prevents accidental release of pressure during the operation.
- User friendly pressure relief system (knob) allows for easy connection and disconnection with residual pressure.
- Please use in conjunction with APM series or AHD series to be able to connect with the matching side (attachment) under residual pressure.
- Low cost field replacement spare kits for couplers and valve.
- Flat face is easy to clean, reducing the inclusion of contamination to the hydraulic circuit.
- Minimal fluid spillage during disconnection, reducing fluid spillage to the environment.
- Minimal air inclusion during connection.
- Internal valve design creates minimal pressure drop, maintaining circuit efficiency in the system
- Good resistance to pressure impulses.
- Compact slim and flexible design (possible to use different sizes of couplings).
- Safe and simple to use.
- Bracket for electrical connector (kit plate + screw included in the box).

HOW TO USE

- Before to connect, clean the mating surface of the couplings to avoid dirt inclusion in the circuit.
- Drain the residual pressure pulling the knob out and up to drain the residual pressure of upper coupling, down to drain the residual pressure of lower coupling.
- To connect push the male half towards the female half or viceversa.
- After connection turn the external sleeve to engage safety lock function, to prevent accidental disconnection.
- To disconnect pull back the sleeve of the female
- In case of residual pressure, before uncoupling drain the residual pressure pulling the knob out and up to drain the residual pressure of upper coupling, down to drain the residual pressure of lower coupling.

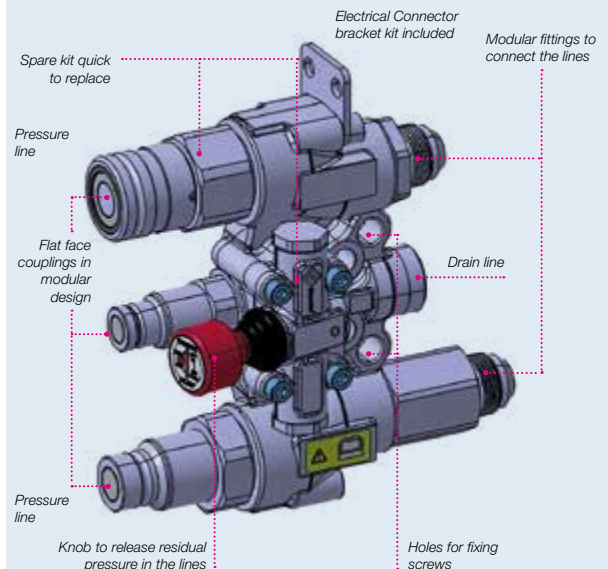
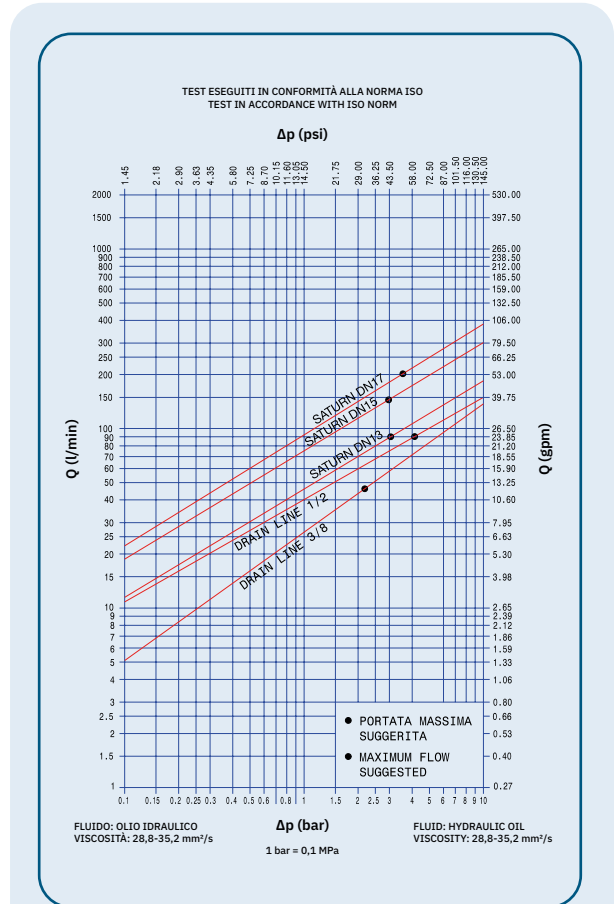

MAIN APPLICATIONS



CASTING

PERFORMANCES

Size		Series/Size	Max. flow suggested		Spillage*
Inch	mm (ISO)		l/min	gpm	ml
1/2	12,5	SATURN DN13	90	23,85	0,02
5/8	16	SATURN DN15	148	39,22	0,03
3/4	19	SATURN DN17	200	53	0,03

Size	Series/Size	Max. operating pressure						Max. residual pressure			
		Coupled		Male		Female		Male		Female	
Inch		MPa	psi	MPa	psi	MPa	psi	MPa	psi	MPa	psi
1/2	SATURN DN13	35	5075	33	4785	33	4785	25	3625	25	3625
5/8	SATURN DN15	35	5075	33	4785	33	4785	25	3625	25	3625
3/4	SATURN DN17	35	5075	33	4785	33	4785	25	3625	25	3625

* Spillage is an indicative value of the fluid loss during disconnection (according to ISO norm test method).

Different possible configurations:

See specific table.

Temperature range:

Seals in NBR (Nitrile): from -20 °C to +100 °C (from -4 °F to +212 °F).
Please read carefully Instructions and warnings for proper selection of the products.

Tests:

The Saturn Block have been tested at impulse with max. operating pressure for 1.000.000 impulses according to ISO norm in connected position.

WARNING

A defect, a wrong choice or an improper use of products, can cause injury to persons, animals and objects.

Connect under pressure products are suitable to be connected under residual (static) pressure.

Never connect or disconnect with dynamic pressure (e.g. pump on).

Do not relieve pressure:

- When the attachment is not in the rest position
- During operation of the attachment (due to danger of unexpected movement of the attachment)

Connection with residual pressure (pressure trapped in the circuit) allowed with one side to drain.

Do not use the female coupling disconnected with high impulse pressure.

Do not couple-uncouple with flow in the circuit.

Do not couple-uncouple when the temperature inside of the circuit is higher than 80 °C (176 °F).

Check the maximum allowable working pressure of the port in use.

It is important to limit contamination in the circuit to avoid compromising the function of the internal valves.

Make sure that the medium used is compatible with seal and material as indicated for each series.

In case of doubt please contact Stucchi Technical Support.

The interchangeability is mentioned under the assumption that the manufacturer of the considered products has not changed any dimension.

It is mandatory to carefully read and closely follow the instructions before selecting or using any Stucchi products.

Always refer to the version uploaded in the Instructions and warning section of stucchigroup.com website for the latest release.

For specific, product-related, instructions, please contact Stucchi technical service.

HOW IT WORKS

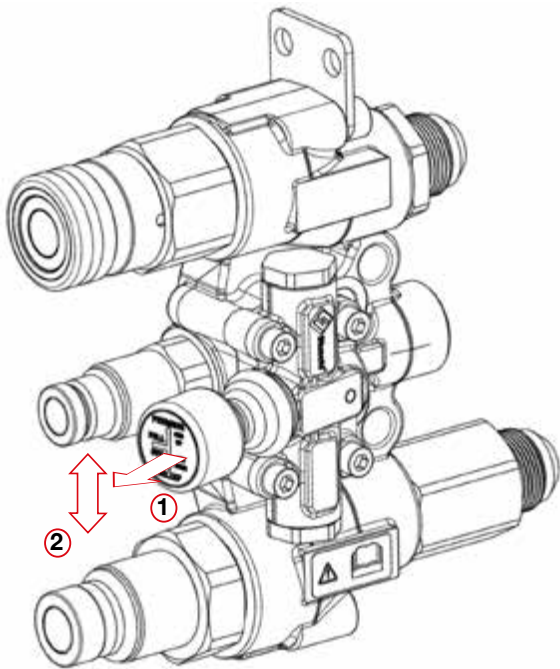

To release the pressure:

- ① Pull the lever
- +
- ② Push up to release the pressure on the upper line
- Push down to release the pressure on the lower line

HYDRAULIC CIRCUIT

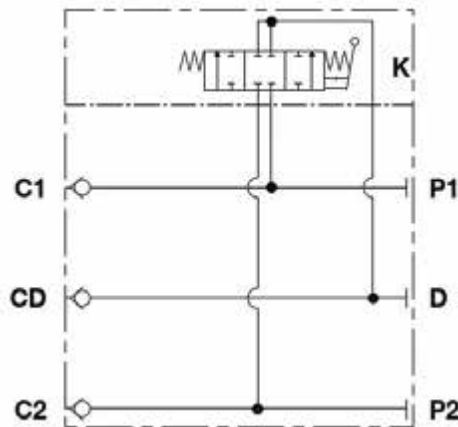

HOW TO ORDER, PRODUCT DEFINITION

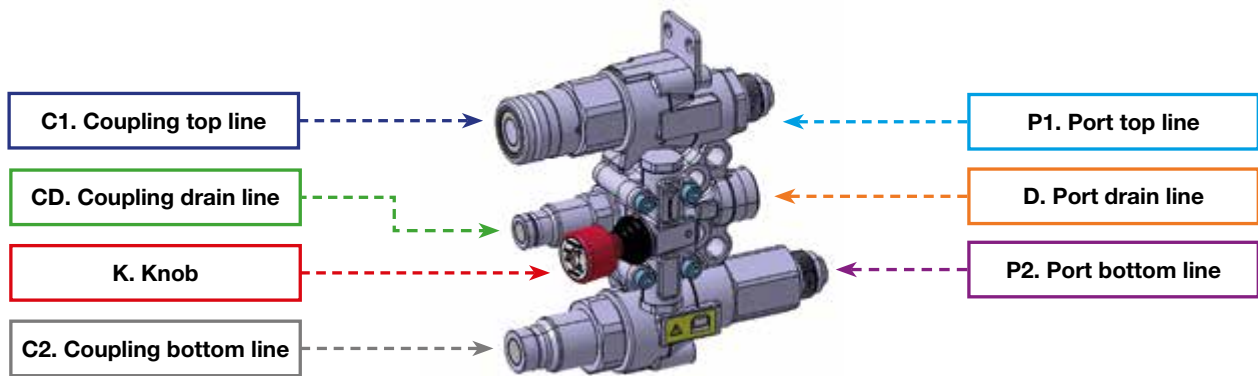

Descriptive Code	Item Code	Lever Side	C1. Coupling top line	CD. Coupling drain line	C2. Coupling bottom line	P1. Port top line	P2. Port bottom line
SATURN WITH M+F A13 + M A9	808800102	LEFT	MALE DN13 1/2"	MALE DN9 3/8"	FEMALE DN13 1/2"	3/4" JIC (long adaptor)	3/4" JIC (short adaptor)
SATURN WITH M+F A15 + M A9	808800103	LEFT	MALE DN15 5/8"	MALE DN9 3/8"	FEMALE DN15 5/8"	3/4" JIC (long adaptor)	3/4" JIC (short adaptor)
SATURN WITH M+F A17 + M A13	808800104	LEFT	FEMALE DN17 3/4"	MALE DN13 1/2"	MALE DN17 3/4"	3/4" JIC (long adaptor)	3/4" JIC (short adaptor)
SATURN WITH M+F A17 + M A9	808800105	LEFT	FEMALE DN17 3/4"	MALE DN9 3/8"	MALE DN17 3/4"	3/4" JIC (long adaptor)	3/4" JIC (short adaptor)
SATURN LEFT WITH M+F A17 + M A9	808800106	RIGHT	MALE DN17 3/4"	MALE DN9 3/8"	FEMALE DN17 3/4"	3/4" SAE	3/4" SAE
SATURN LEFT WITH M+F A13 + CAP A13	808800107	RIGHT	MALE DN13 1/2"	PLUGGED	FEMALE DN13 1/2"	3/4" SAE	3/4" SAE
SATURN LEFT WITH M+F A13 + M A9	808800108	RIGHT	MALE DN13 1/2"	MALE DN9 3/8"	FEMALE DN13 1/2"	3/4" JIC (short adaptor)	3/4" JIC (short adaptor)
SATURN LEFT WITH M+F13 + M A9	808800121	LEFT	MALE DN13 1/2"	MALE DN9 3/8"	FEMALE DN13 1/2"	3/4" JIC (long adaptor)	3/4" JIC (short adaptor)

OVERALL DIMENSIONS

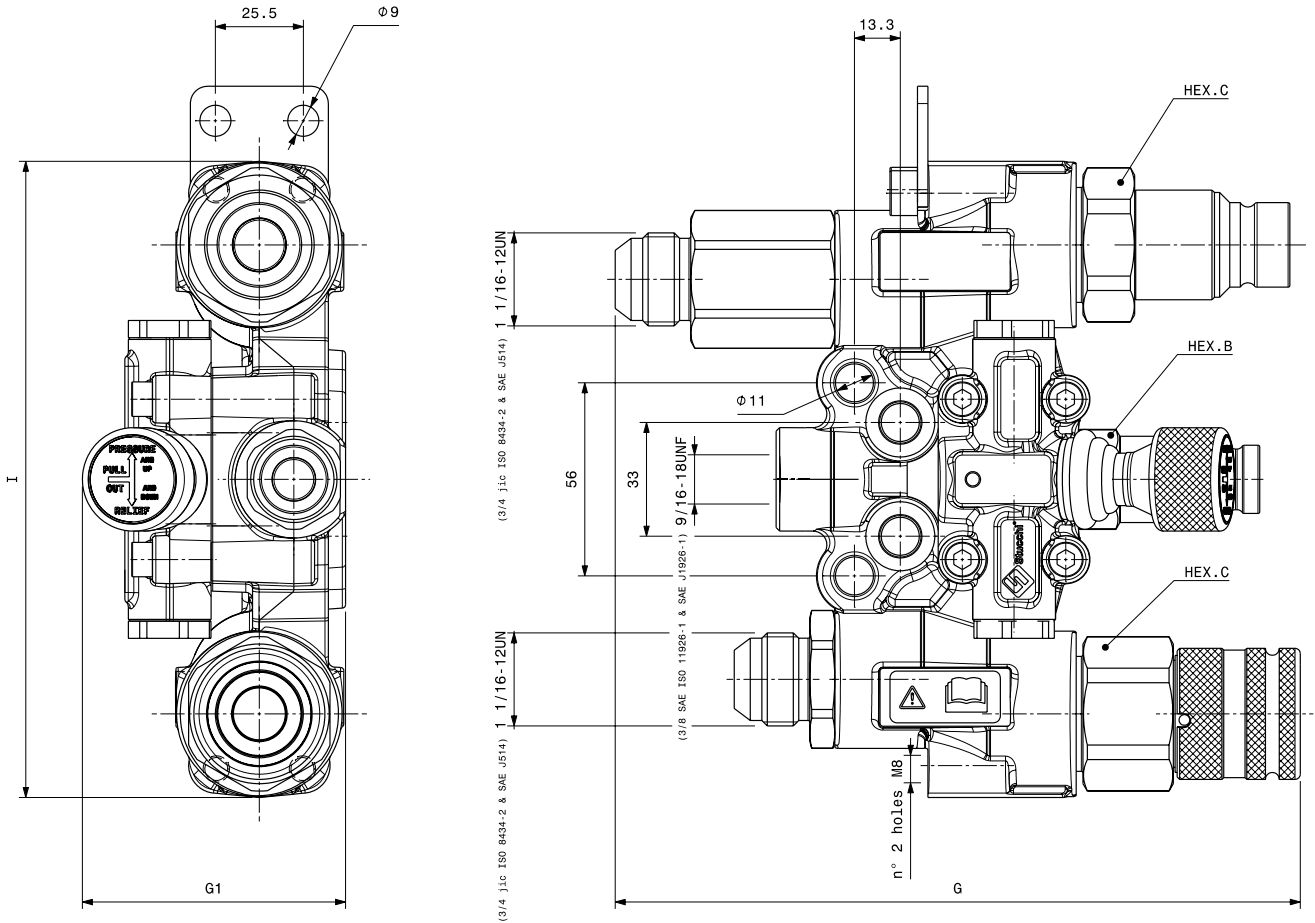

Descriptive Code	Length		G1	Length		I	Length		Hex		Hex		Weight				
	mm	inch		mm	inch		mm	inch	mm	inch	mm	inch	Kg	Lbs			
SATURN DN13	G	196,8	7,75	G1	76,0	2,99	I	184,0	7,24	C	41,0	1,61	B	27,0	1,06	4,31	9,51
SATURN DN15	G	203,7	7,75	G1	76,0	2,99	I	184,0	7,24	C	41,0	1,61	B	27,0	1,06	4,44	9,78
SATURN DN17	G	224,0	7,75	G1	76,0	2,99	I	184,0	7,24	C	46,0	1,81	B	32,0	1,26	5,05	11,14



SPARE KIT SEAL FOR MALE

Repair kit / OR+BK		
Body Size	Description	Part Number
3/8"	M A9 (drain line)	815700337
1/2"	MALE DIN13	815700339
5/8"	MALE DIN15	815700341
3/4"	MALE DIN17	815700343

Backup ring
(Teflon®)

O-ring

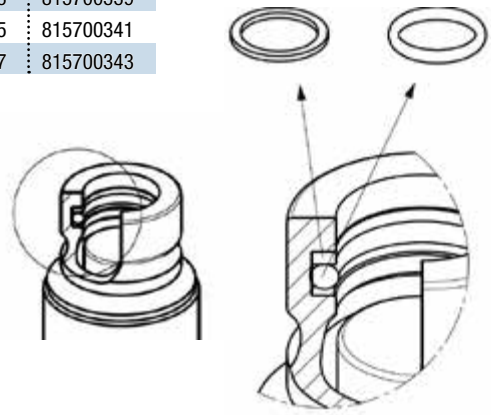

O-Ring in NBR
BackUp in Teflon®

REPAIR KIT FOR SATURN SERIES

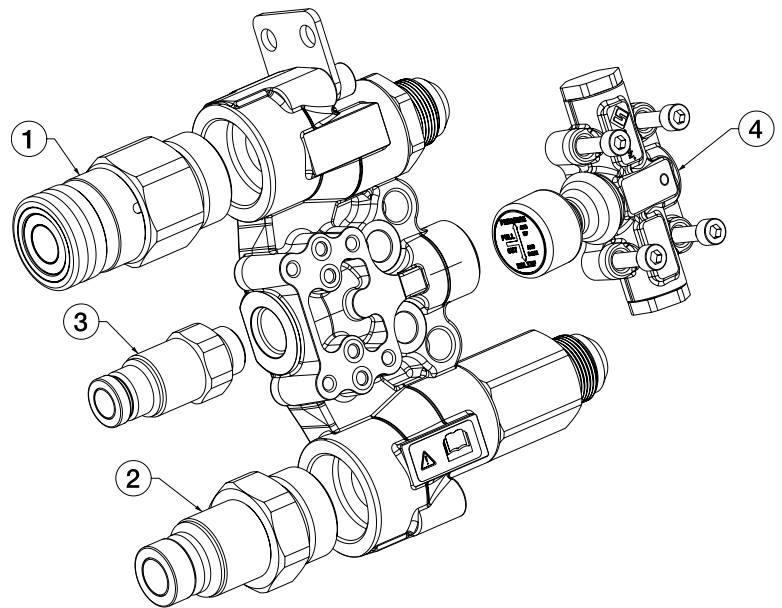

Repair kit			
Body Size	Descriptive Code	Part Number	Legend
1/2"	CARTRIDGE F A13HDSP 1 ORFS (DIN13)	808313038	1
1/2"	CARTRIDGE M A13HD 1 ORFS (DIN13)	808313001	2
5/8"	CARTRIDGE F A15HDS 1 ORFS (DIN15)	808313032	1
5/8"	CARTRIDGE M A15HD 1 ORFS (DIN15)	808313003	2
3/4"	CARTRIDGE F A17 1 ORFS (DIN17)	801313010	1
3/4"	CARTRIDGE M A17 1 ORFS (DIN17)	801313011	2
3/8"	CARTRIDGE M A9 1/2 SAE EXT	801304033	3
1/2"	CARTRIDGE M A13RN 1/2 SAE EST	801304049	3
-	CARTRIDGE REPAIR KIT VALVE GROUP	815700866	4

Male or Female coupling can be mounted indifferently either on the top or bottom port



SATURN HF SERIES

INTERCHANGE > ISO 16028 (for the couplings)



Easy CUP



TECHNICAL FEATURES AND OPTIONS

Interchange ISO 16028 (for the couplings)	Sealing description Nitrile NBR	Connection system Push
Available sizes from 1/2" to 3/4"	Material/treatment Carbon steel /Cr3	Available threads SAE - JIC
Operating pressure Up to 350 bar	Locking mechanism Locking ball + Safety Lock	Flow rate Up to 200 l/min
Temperature (°C) -20° / +100°	Valving style Flat face	Connection under pressure Connection: One side - Both side if use with APM/AHD (see Benefits). Disconnection: Allowed (see Benefits).

BENEFITS

- Stucchi design pressure relief system completely independent of the connections prevents accidental release of pressure during the operation.
- The two supplementary lines integrated in the casting make the Saturn HF a simple product to be assembled on the machines, thus reducing installation costs.
- User friendly pressure relief system (knob) allows the release of residual pressure in all the coupling just by two movements (pull and up) for easy and safe connection and disconnection.
- Please use in conjunction with APM series or A-HD series to be able to connect with the matching side (attachment) under residual pressure.
- Low cost field replacement spare kits for couplers and valve.
- Flat face is easy to clean, reducing the inclusion of contamination to the hydraulic circuit.
- Minimal fluid spillage during disconnection, reducing fluid loss to the environment.
- Minimal air inclusion during connection.
- Internal valve design creates minimal pressure drop, maintaining circuit efficiency in the system.
- Good resistance to pressure impulses.
- Compact slim and flexible design (possible to use different sizes of couplings).
- Safe and simple to use.

HOW TO USE

- Before to connect, clean the mating surface of the couplings to avoid dirt inclusion in the circuit.
- Drain the residual pressure pulling the knob out and up to drain the residual pressure of all the couplings.
- To connect push the male half towards the female half or viceversa.
- After connection turn the external sleeve to engage safety lock function, to prevent accidental disconnection.
- To disconnect pull back the sleeve of the female.
- In case of residual pressure, before uncoupling pull the knob out and up to drain the residual pressure of the couplings.

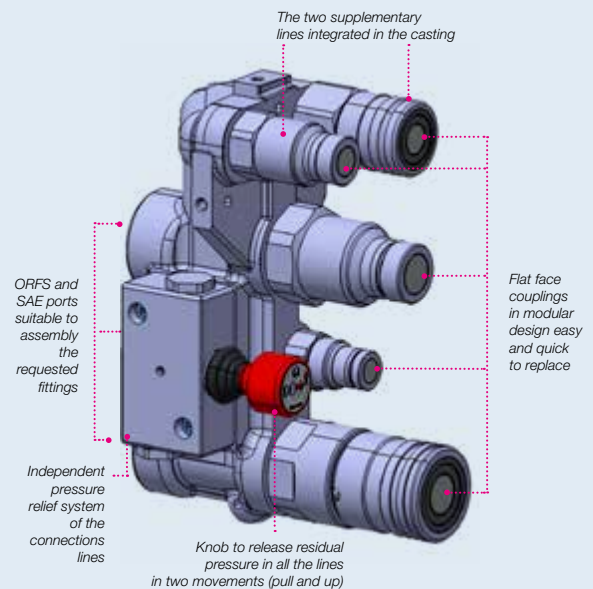
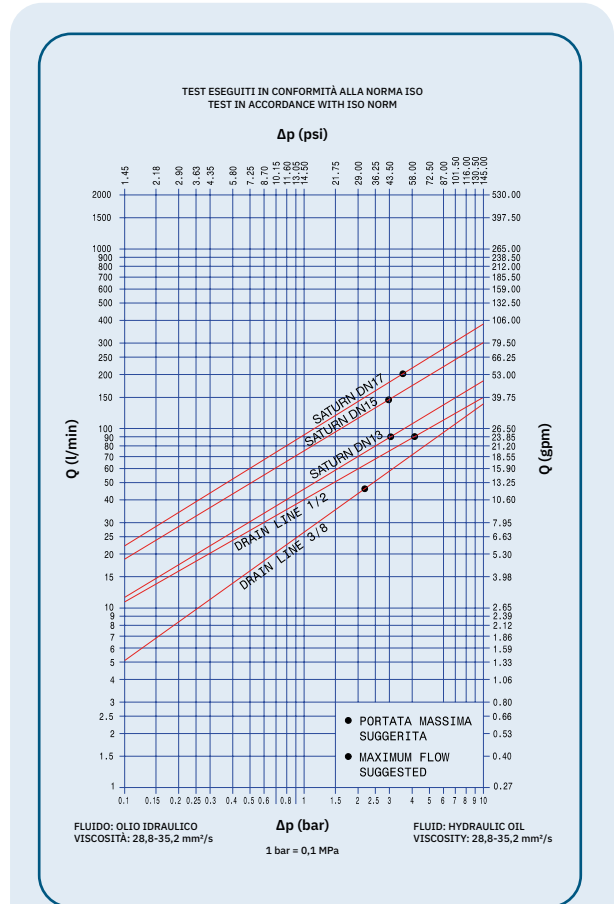

MAIN APPLICATIONS



CASTING

PERFORMANCES

Size		Series/Size	Max. flow suggested		Spillage*
Inch	mm (ISO)		l/min	gpm	ml
1/2	12,5	SATURN DN13	90	23,85	0,02
3/4	19	SATURN DN17	200	53	0,03

Size	Series/Size	Max. operating pressure						Max. residual pressure			
		Coupled		Male		Female		Male		Female	
Inch		MPa	psi	MPa	psi	MPa	psi	MPa	psi	MPa	psi
1/2	SATURN DN13	35	5075	33	4785	33	4785	25	3625	25	3625
3/4	SATURN DN17	35	5075	33	4785	33	4785	25	3625	25	3625

* Spillage is an indicative value of the fluid loss during disconnection (according to ISO norm test method).

Different possible configurations:

See specific table.

Temperature range:

Seals in NBR (Nitrile): from -20 °C to +100 °C (from -4 °F to +212 °F).

Please read carefully Instructions and warnings for proper selection of the products.

Tests:

The Saturn Block have been tested at impulse with max. operating pressure for 1.000.000 impulses according to ISO norm in connected position.

WARNING

A defect, a wrong choice or an improper use of products, can cause injury to persons, animals and objects.

Connect under pressure products are suitable to be connected under residual (static) pressure.

Never connect or disconnect with dynamic pressure (e.g. pump on).

Do not relieve pressure:

- When the attachment is not in the rest position

- During operation of the attachment (due to danger of unexpected movement of the attachment)

Connection with residual pressure (pressure trapped in the circuit) allowed with one side to drain.

Do not use the female coupling disconnected with high impulse pressure.

Do not couple-uncouple with flow in the circuit.

Do not couple-uncouple when the temperature inside of the circuit is higher than 80 °C (176 °F).

Check the maximum allowable working pressure of the port in use.

It is important to limit contamination in the circuit to avoid compromising the function of the internal valves.

Make sure that the medium used is compatible with seal and material as indicated for each series.

In case of doubt please contact Stucchi Technical Support.

The interchangeability is mentioned under the assumption that the manufacturer of the considered products has not changed any dimension.

It is mandatory to carefully read and closely follow the instructions before selecting or using any Stucchi products.

Always refer to the version uploaded in the Instructions and warning section of stucchigroup.com website for the latest release.

For specific, product-related, instructions, please contact Stucchi technical service.

HOW IT WORKS

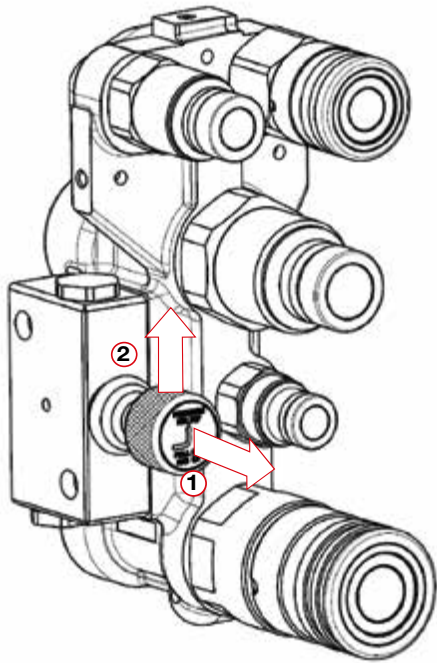

To release the pressure:

- ① Pull the lever
- +
- ② Push up to release the pressure in all the lines

HYDRAULIC CIRCUIT

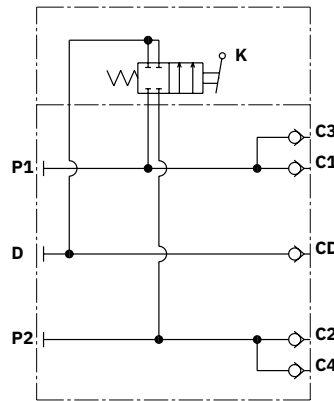

HOW TO ORDER, PRODUCT DEFINITION

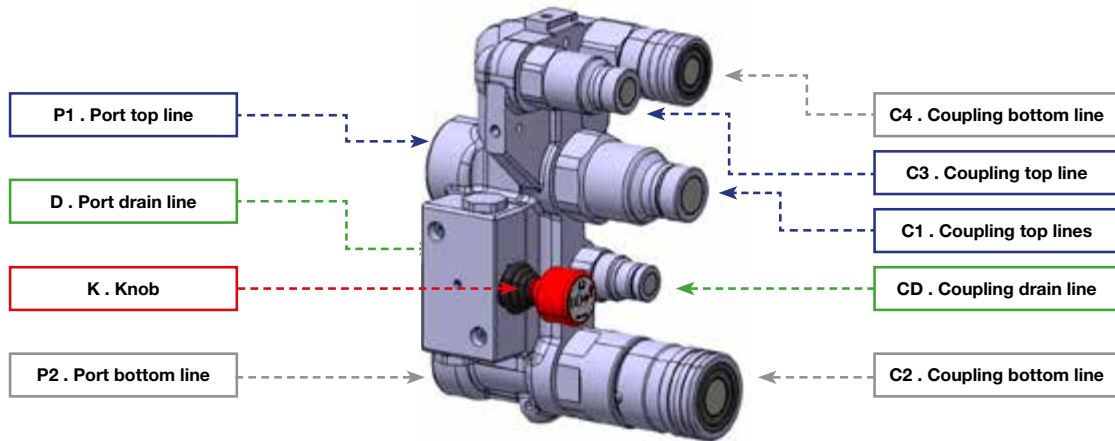

Descriptive Code	Item Code	C1. Coupling top line	C2. Coupling bottom line	C3. Coupling top line	C4. Coupling bottom line	CD. Coupling drain line
SATURN HF M+FA17 + M+FA13 + MA9	808800120	Male 3/4	Female 3/4	Male 1/2	Female 1/2	Male 3/8

OVERALL DIMENSIONS

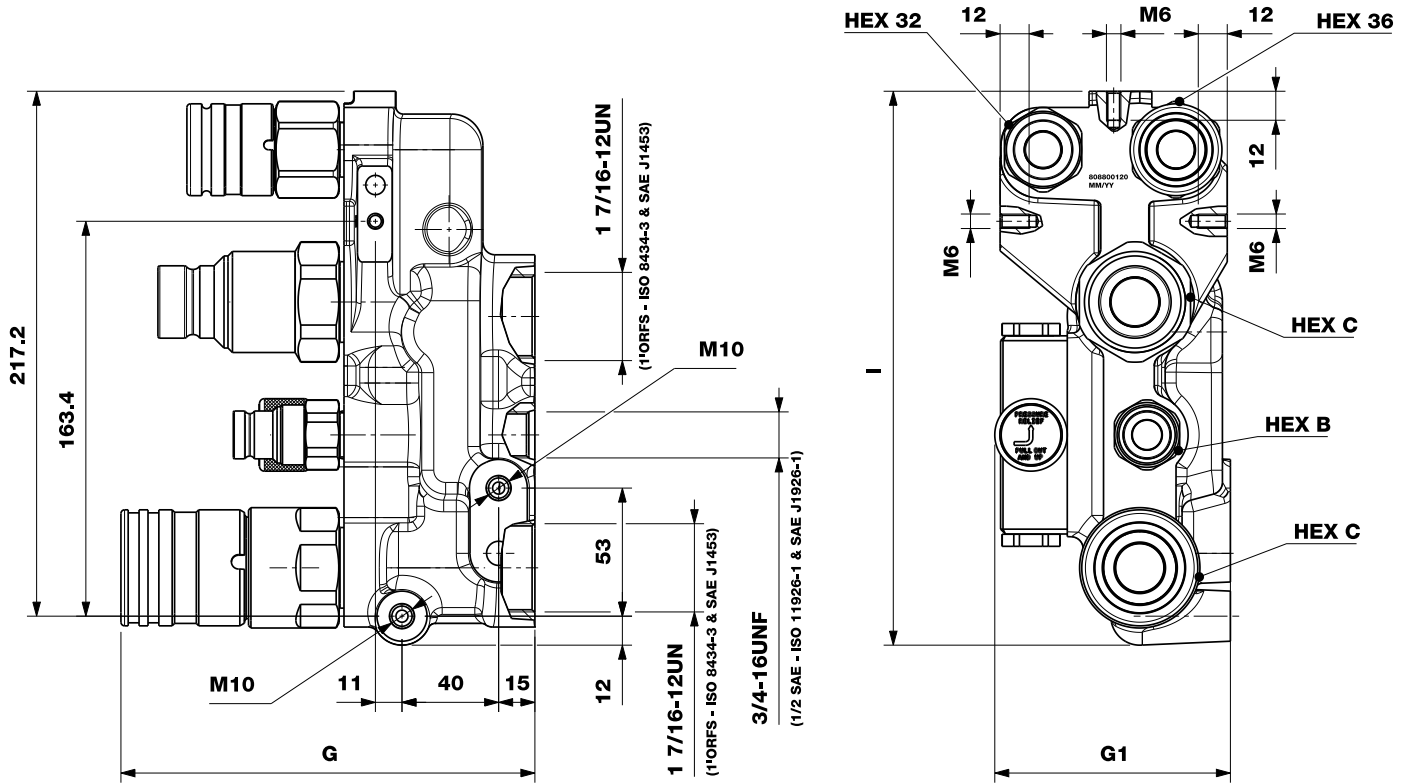

Descriptive Code	Length		Length		Length		Hex		Hex		Weight						
	mm	inch	mm	inch	mm	inch	mm	inch	mm	inch	Kg	Lbs					
SATURN HF M+F A17 + M+F A13 + M A9	G	171,3	6,74	G1	97,5	3,84	I	229,2	9,02	C	46	1,81	B	27,0	1,06	7,84	17,28



SPARE KIT SEAL FOR MALE

Repair kit / OR+BK		
Body Size	Description	Part Number
3/8"	M A9 (drain line)	815700337
1/2"	MALE DIN13	815700339
3/4"	MALE DIN17	815700343

Backup ring
(Teflon®)

O-ring

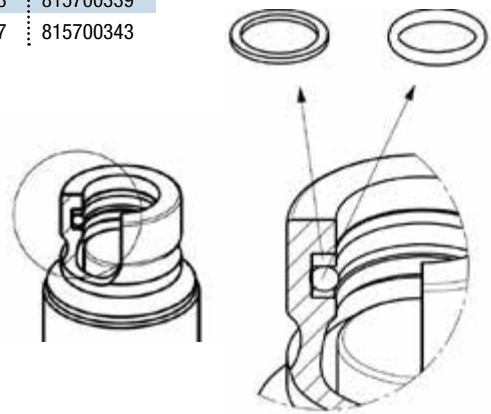

O-Ring in NBR
BackUp in Teflon®

REPAIR KIT FOR SATURN HF SERIES

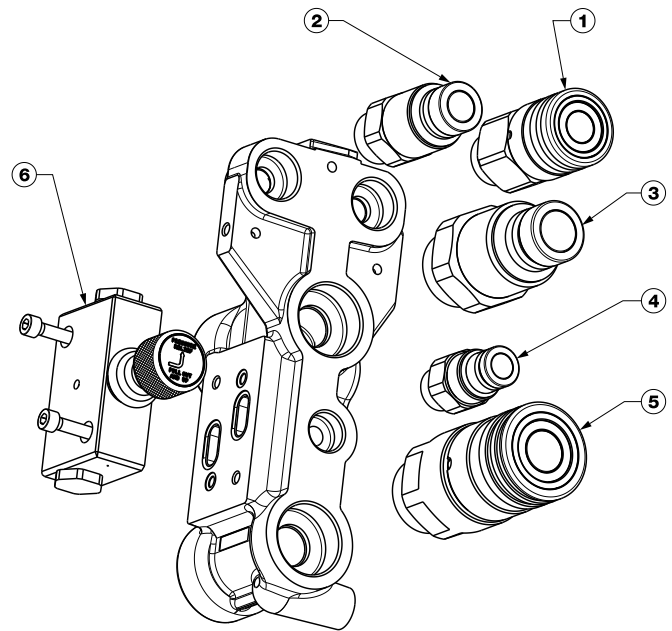

Repair kit			
Coupling Size	Descriptive Code	Part Number	Legend
1/2"	F A13HDS 5/8 ORFS	808313042	1
1/2"	M A13HD 5/8 ORFS	808313037	2
3/4"	M A17 1 ORFS	801313011	3
3/8"	M AS9 1/2 ORFS (drain line)	806613001	4
3/4"	F A17 1 ORFS	801313010	5
na	REPAIR KIT VALVE GROUP SATURN HF	815701278	6





VD p. 113

Valving style: Poppet
 Interchange: ISO 14541
 Sealing description: Nitrile NBR
 Available sizes: From 1/4" to 1-1/4"
 Operating pressure: Up to 450 bar
 Flow rate: Up to 378 l/min
 Material / Treatment:
 Carbon steel / Cr3
 Connection under pressure:
 One side only



VLS p. 123

Valving style: Poppet
 Interchange: With similar couplings
 Sealing description: Nitrile NBR
 Available sizes: From 1/2" to 1"
 Operating pressure: Up to 465 bar
 Flow rate: Up to 200 l/min
 Material / Treatment:
 Carbon steel / Cr3
 Connection under pressure:
 One side only

BOP



VOF p. 129

Valving style: Poppet
 Interchange: With similar couplings
 Sealing description: Nitrile NBR
 Available sizes: From 3/4" to 2"
 Operating pressure: Up to 345 bar
 Flow rate: Up to 1100 l/min
 Material / Treatment:
 Carbon steel / Cr3
 Connection under pressure:
 One side only

BOP



VOFX p. 135

Valving style: Poppet
 Interchange: With similar couplings
 Sealing description: Nitrile NBR
 Available sizes: From 3/4" to 2"
 Operating pressure: Up to 207 bar
 Flow rate: Up to 1100 l/min
 Material / Treatment:
 Stainless steel (AISI 316L)
 Connection under pressure:
 One side only



VR p. 141

Valving style: Flat face non-spill
 Interchange: With Rohrleitung couplings
 Sealing description: Nitrile NBR
 Available sizes: From 3/8" to 1-1/4"
 Operating pressure: Up to 420 bar
 Flow rate: Up to 576 l/min
 Material / Treatment:
 Carbon steel / Cr3
 Connection under pressure:
 One side only



VD SERIES

INTERCHANGE > ISO 14541



TECHNICAL FEATURES AND OPTIONS

Interchange ISO 14541	Sealing description Nitrile NBR	Connection system Screw
Available sizes from 1/4" to 1-1/4"	Material/treatment Carbon steel /Cr3	Available threads BSP - METRIC
Operating pressure Up to 450 bar	Locking mechanism Screw to connect	Flow rate Up to 378 l/min
Temperature (°C) -20° / +100°	Valving style Poppet	Connection under pressure Connection: one side Disconnection: not allowed

BENEFITS

- Connection is allowed with residual pressure in one side of the coupling (max 100 bar in one side)
- The poppet valve with elastomer seal provides maximum sealing of the couplings when disconnected.
- Shape of internal parts is designed to reduce turbulence and pressure drop.
- The modular design allows for broad range of port configurations.
- External o-ring indicates if the product is fully connected, prevent accidental disconnection and protect coupling against dirt.
- Male body sealing surface protected by the threaded sleeve.
- High resistance to pressure impulses.
- Compact design.
- Simple to use.

HOW TO USE

- Before to connect, clean the mating surface of the couplings to avoid dirt inclusion in the circuit.
- To connect insert the male coupling in the female coupling, screw the sleeve till its positive stop, do not push together the couplings, screw only.
- The use of tools for the second part of the connection can be necessary if there is high residual pressure in the circuit.
- Check that the external O-ring is fully covered.
- To disconnect unscrew totally the sleeve from the female coupling.

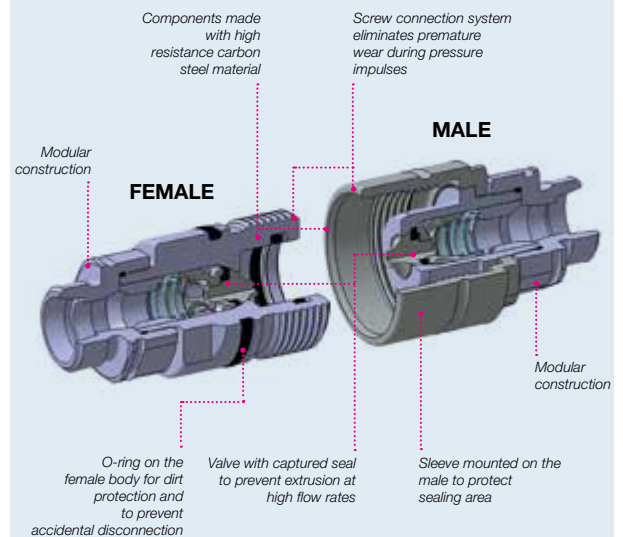
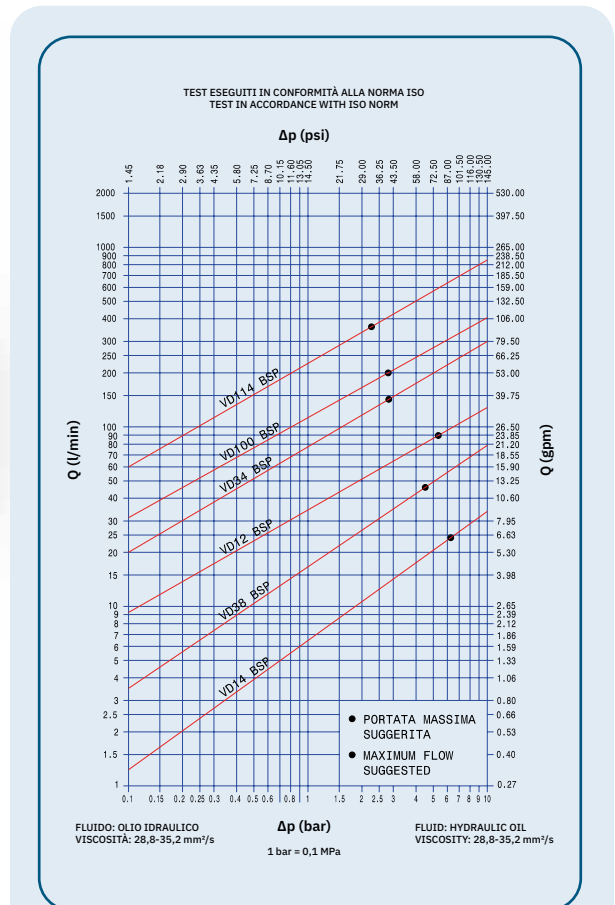

MAIN APPLICATIONS

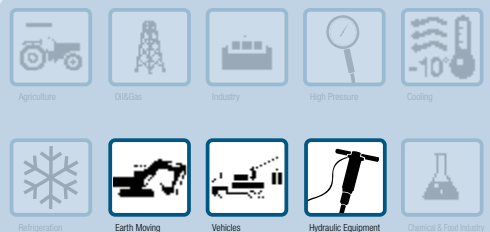

PERFORMANCES

Size		Series/Size	BG	Max. flow suggested		Manual connect torque*		Manual disconnect torque*		Spillage**
Inch	mm (ISO)			l/min	gpm	Nm	lbf ft	Nm	lbf ft	ml
1/4	6,3	VD14	1	24	6,36	0,8	0,59	0,5	0,37	0,7
3/8	10	VD38	2	46	12,19	1,0	0,74	0,5	0,37	1
1/2	12,5	VD12	3	90	23,85	1,5	1,11	1,2	0,88	3
3/4	20	VD34	4	148	39,22	2,5	1,84	2,2	1,62	5
1	-	VD100	6	200	53,00	2,7	1,99	2,2	1,62	14
1-1/4	-	VD114	8	378	100,17	5,0	3,69	5,0	3,69	51

Size	Series/Size	Max. operating pressure						Burst pressure					
		Coupled		Male		Female		Coupled		Male		Female	
Inch		MPa	psi	MPa	psi	MPa	psi	MPa	psi	MPa	psi	MPa	psi
1/4	VD14	45	6525	45	6525	45	6525	160	17400	140	20300	160	20300
3/8	VD38	45	6525	45	6525	45	6525	140	17400	120	17400	140	17400
1/2	VD12	40	5800	40	5800	40	5800	140	17400	120	17400	120	17400
3/4	VD34	40	5800	40	5800	40	5800	100	17400	100	14500	100	17400
1	VD100	30	4350	30	4350	30	4350	100	14500	100	14500	100	14500
1-1/4	VD114	30	4350	30	4350	30	4350	100	14500	100	14500	100	14500

* Connect torque and disconnect torque without residual pressure.
The torque will increase as internal residual pressure increases.

** Spillage is an indicative value of the fluid loss during disconnection (according to ISO norm test method).

Different possible configurations:

Different threads available upon request.

Temperature range:

Standard seals NBR (Nitrile): from -20 °C to +100 °C (from -4 °F to +212 °F).
Please read carefully Instructions and warnings for proper selection of the products.

Tests performed:

The couplings have been tested at maximum operating pressure for 500.000 impulses according to ISO norm test method.

⚠ WARNING

A defect, a wrong choice or an improper use of products, can cause injury to persons, animals and objects.

Never connect or disconnect with dynamic pressure (e.g. pump on).

Do not couple-uncouple with flow in the circuit.

Do not couple-uncouple when the temperature inside of the circuit is higher than 80 °C (176 °F).

Do not use the coupling disconnected with high impulse pressure.

Connect under pressure products are suitable to be connected under residual (static) pressure.

Connection with residual pressure (pressure trapped in the circuit) allowed with other side coupling to drain.

Check the maximum allowable working pressure of the port in use.

Make sure that the medium used is compatible with seal and material as indicated for each series.

In case of doubt please contact Stucchi Technical Support.

The interchangeability is mentioned under the assumption that the manufacturer of the considered products has not changed any dimension.

It is mandatory to carefully read and closely follow the instructions before selecting or using any Stucchi products.

Always refer to the version uploaded in the Instructions and warning section of stucchigroup.com website for the latest release.

For specific, product-related, instructions, please contact Stucchi technical service.

OVERALL DIMENSIONS

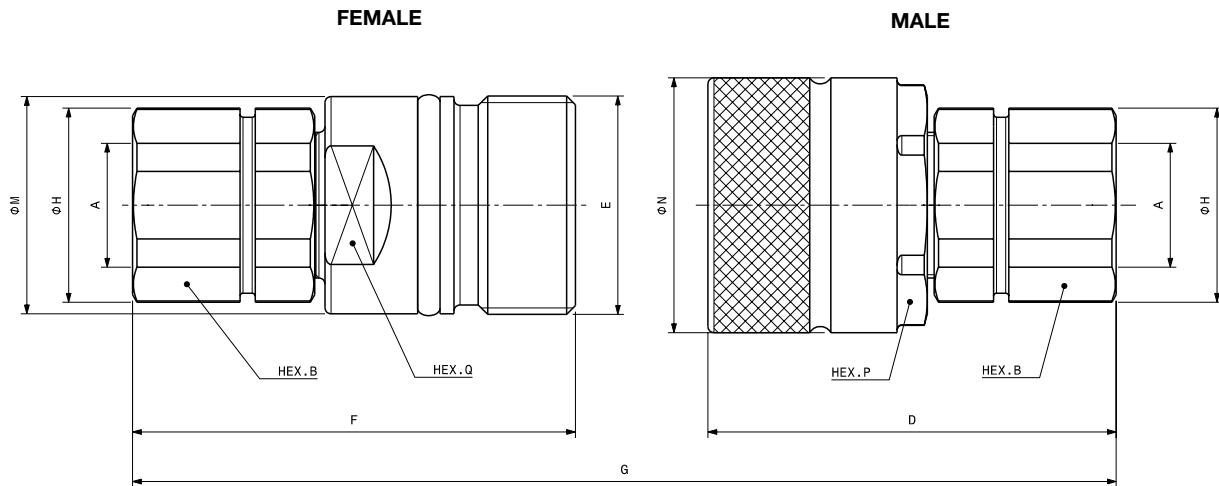

Port description: FEMALE THREAD BSPP (ISO 1179-1)

BODY SIZE	Descriptive Code	Item Code	ISO DN	BG	PORT (A)	E	Overall Length		Length		Hex		Diameter		Hex		Diameter		Weight							
							mm	inch	mm	inch	mm	inch	mm	inch	mm	inch	mm	inch	Kg	Lbs						
1/4"	F VD14 BSP	Female 809500006	6,3	1	1/4"	M24X2	G	94,5	3,72	F	61,7	2,44	B	19,0	0,75	M	23,8	0,94	Q	22,0	0,87	H	21,0	0,83	0,13	0,28
	M VD14 BSP	Male 809500007								D	58,5	2,31	N	30,0	1,18	P	27,0	1,06	N	30,0	1,18	H	21,0	0,83	0,14	0,31
3/8"	F VD38-14 BSP	Female 809500008	10	2	1/4"	M28X2	G	99,0	3,90	F	64,3	2,53	B	22,0	0,87	M	27,8	1,09	Q	24,0	0,94	H	24,0	0,94	0,19	0,41
	M VD38-14 BSP	Male 809500009								D	61,5	2,43	N	34,0	1,34	P	30,0	1,18	N	34,0	1,34	H	24,0	0,94	0,19	0,41
3/8"	F VD38 BSP	Female 809500010	10	2	3/8"	M28X2	G	105,0	4,13	F	67,3	2,65	B	22,0	0,87	M	27,8	1,09	Q	24,0	0,94	H	24,0	0,94	0,19	0,18
	M VD38 BSP	Male 809500011								D	64,5	2,55	N	34,0	1,34	P	30,0	1,18	N	34,0	1,34	H	24,0	0,94	0,19	0,41
1/2"	F VD12-38 BSP	Female 809500000	12,5	3	3/8"	M36X2	G	102,6	4,04	F	68,0	2,68	B	30,0	1,18	M	35,8	1,41	Q	30,0	1,18	H	32,0	1,26	0,35	0,77
	M VD12-38 BSP	Male 809500001								D	62,3	2,45	N	42,0	1,65	P	36,0	1,42	N	42,0	1,65	H	32,0	1,26	0,30	0,66
1/2"	F VD12 BSP	Female 809500002	12,5	3	1/2"	M36X2	G	112,6	4,43	F	73,0	2,87	B	30,0	1,18	M	35,8	1,41	Q	30,0	1,18	H	32,0	1,26	0,34	0,74
	M VD12 BSP	Male 809500003								D	67,3	2,65	N	42,0	1,65	P	36,0	1,42	N	42,0	1,65	H	32,0	1,26	0,29	0,63
3/4"	F VD34-12 BSP	Female 809500014	20	4	1/2"	M42X2	G	117,5	4,63	F	79,4	3,13	B	36,0	1,42	M	41,8	1,65	Q	36,0	1,42	H	40,0	1,57	0,54	1,19
	M VD34-12 BSP	Male 809500015								D	69,9	2,76	N	49,5	1,89	P	46,0	1,81	N	49,5	1,89	H	40,0	1,57	0,48	1,05
3/4"	F VD34 BSP	Female 809500016	20	4	3/4"	M42X2	G	129,3	5,09	F	85,3	3,36	B	36,0	1,42	M	41,8	1,65	Q	36,0	1,42	H	40,0	1,57	0,55	1,21
	M VD34 BSP	Male 809500017								D	75,8	2,99	N	49,5	1,89	P	46,0	1,81	N	49,5	1,89	H	40,0	1,57	0,43	0,95
1"	F VD100-34 BSP	Female 809500018	25	6	3/4"	48X3 SP*	G	139,7	5,50	F	95,5	3,76	B	41,0	1,61	M	47,8	1,88	Q	41,0	1,61	H	45,0	1,77	0,75	1,64
	M VD100-34 BSP	Male 809500019								D	79,0	3,11	N	60,0	2,17	P	55,0	1,97	N	60,0	2,17	H	45,0	1,77	0,65	1,43
1"	F VD100 BSP	Female 809500020	25	6	1"	48X3 SP*	G	150,7	5,93	F	101,0	3,98	B	41,0	1,61	M	47,8	1,88	Q	41,0	1,61	H	45,0	1,77	0,74	1,63
	M VD100 BSP	Male 809500021								D	84,5	3,33	N	60,0	2,17	P	55,0	1,97	N	60,0	2,17	H	45,0	1,77	0,64	1,41
1-1/4"	F VD114 BSP	Female 809500022	31,5	8	1 - 1/4"	70X3 SP*	G	189,0	7,44	F	117,2	4,61	B	55,0	2,17	M	68,5	2,70	Q	65,0	2,56	H	61,0	2,40	1,70	3,74
	M VD114 BSP	Male 809500023								D	121,0	4,76	N	85 CH80 **	3,35 - CH3,15 **	P	80,0	3,15	N	85 CH80 **	3,35 - CH3,15 **	H	61,0	2,40	2,48	5,46
1-1/4"	F VD114-112 BSP	Female 809500024	31,5	8	1 - 1/2"	70X3 SP*	G	201,0	7,91	F	123,2	4,85	B	55,0	2,17	M	68,5	2,70	Q	65,0	2,56	H	61,0	2,40	1,66	3,66
	M VD114-112 BSP	Male 809500025								D	127,0	5,00	N	85 CH80 **	3,35 - CH3,15 **	P	80,0	3,15	N	85 CH80 **	3,35 - CH3,15 **	H	61,0	2,40	2,44	5,38

*SP = SPECIAL THREAD
**HEXAGON SLEEVE

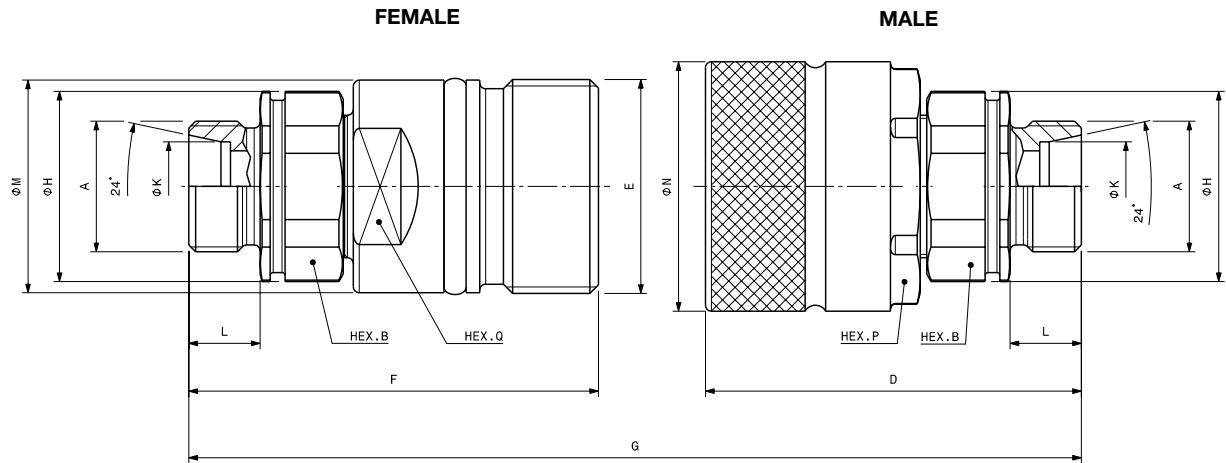

Port description: MALE THREAD METRIC L – 24° CONE (ISO 8434-1 & DIN 2353)

BODY SIZE	Descriptive Code	Item Code	ISO DN	BG	PORT (A)	E	Overall Length		Length		Length		Hex		Diameter		Hex		Diameter		Weight												
							mm	inch	mm	inch	mm	inch	mm	inch	mm	inch	mm	inch	mm	inch	mm	inch	Kg	Lbs									
1/4"	F VD14 L8	Female	809508012	6,3	1	M14X1	M24X2	G	90,5	3,56	F	59,7	2,36	L	10,0	0,39	B	19,0	0,75	K	8,0	0,31	M	23,8	0,94	Q	22,0	0,87	H	21,0	0,83	0,10	0,046
	M VD14 L8	Male	809508013								D	56,5	2,23										N	30,0	1,18	P	27,0	1,06			0,10	0,047	
3/8"	F VD38 L8	Female	809508014	10	2	M14X1.5	M28X2	G	93,0	3,66	F	61,3	2,41	L	10,0	0,39	B	22,0	0,87	K	8,0	0,31	M	27,8	1,09	Q	24,0	0,94	H	24,0	0,94	0,16	0,070
	M VD38 L8	Male	809508015								D	58,5	2,31										N	34,0	1,34	P	30,0	1,18			0,14	0,063	
3/8"	F VD38 L10	Female	809508016	10	2	M16X1.5	M28X2	G	95,0	3,74	F	62,3	2,45	L	11,0	0,43	B	22,0	0,87	K	10,0	0,39	M	27,8	1,09	Q	24,0	0,94	H	24,0	0,94	0,17	0,07
	M VD38 L10	Male	809508017								D	59,5	2,35										N	34,0	1,34	P	30,0	1,18			0,14	0,06	
3/8"	F VD38 L12	Female	809508018	10	2	M18X1.5	M28X2	G	95,0	3,74	F	62,3	2,45	L	11,0	0,43	B	22,0	0,87	K	12,0	0,47	M	27,8	1,09	Q	24,0	0,94	H	24,0	0,94	0,14	0,06
	M VD38 L12	Male	809508019								D	59,5	2,35										N	34,0	1,34	P	30,0	1,18			0,14	0,06	
1/2"	F VD12 L8	Female	809508002	12,5	3	M14X1.5	M36X2	G	100,6	3,96	F	67,0	2,64	L	10,0	0,39	B	30,0	1,18	K	8,0	0,31	M	35,8	1,41	Q	30,0	1,18	H	32,0	1,26	0,26	0,12
	M VD12 L8	Male	809508003								D	61,3	2,41										N	42,0	1,65	P	36,0	1,42			0,21	0,10	
1/2"	F VD12 L10	Female	809508006	12,5	3	M16X1.5	M36X2	G	102,6	4,04	F	68,0	2,68	L	11,0	0,43	B	30,0	1,18	K	10,0	0,39	M	35,8	1,41	Q	30,0	1,18	H	32,0	1,26	0,30	0,13
	M VD12 L10	Male	809508007								D	62,3	2,45										N	42,0	1,65	P	36,0	1,42			0,21	0,10	
1/2"	F VD12 L12	Female	809508000	12,5	3	M18X1.5	M36X2	G	102,6	4,04	F	68,0	2,68	L	11,0	0,43	B	30,0	1,18	K	12,0	0,47	M	35,8	1,41	Q	30,0	1,18	H	32,0	1,26	0,26	0,12
	M VD12 L12	Male	809508001								D	62,3	2,45										N	42,0	1,65	P	36,0	1,42			0,21	0,10	
1/2"	F VD12 L15	Female	809508004	12,5	3	M22X1.5	M36X2	G	104,6	4,12	F	69,0	2,72	L	12,0	0,47	B	30,0	1,18	K	15,0	0,59	M	35,8	1,41	Q	30,0	1,18	H	32,0	1,26	0,26	0,12
	M VD12 L15	Male	809508005								D	63,3	2,49										N	42,0	1,65	P	36,0	1,42			0,21	0,10	
1/2"	F VD12 L18	Female	809508008	12,5	3	M26X1.5	M36X2	G	104,6	4,12	F	69,0	2,72	L	12,0	0,47	B	30,0	1,18	K	18,0	0,71	M	35,8	1,41	Q	30,0	1,18	H	32,0	1,26	0,27	0,12
	M VD12 L18	Male	809508009								D	63,3	2,49										N	42,0	1,65	P	36,0	1,42			0,22	0,10	
3/4"	F VD34 L12	Female	809508022	20	4	M18X1.5	M42X2	G	116,5	4,59	F	78,9	3,11	L	11,0	0,43	B	36,0	1,42	K	12,0	0,47	M	41,8	1,65	Q	36,0	1,42	H	40,0	1,57	0,40	0,18
	M VD34 L12	Male	809508023								D	69,4	2,74										N	49,5	1,95	P	46,0	1,61			0,34	0,15	
3/4"	F VD34 L15	Female	809508024	20	4	M22X1.5	M42X2	G	118,5	4,67	F	79,9	3,15	L	12,0	0,47	B	36,0	1,42	K	15,2	0,60	M	41,8	1,65	Q	36,0	1,42	H	40,0	1,57	0,40	0,18
	M VD34 L15	Male	809508025								D	70,4	2,78										N	49,5	1,95	P	46,0	1,61			0,34	0,15	
3/4"	F VD34 L18	Female	809508026	20	4	M26X1.5	M42X2	G	120,5	4,74	F	80,9	3,19	L	12,0	0,47	B	36,0	1,42	K	18,2	0,72	M	41,8	1,65	Q	36,0	1,42	H	40,0	1,57	0,41	0,18
	M VD34 L18	Male	809508027								D	71,4	2,81										N	49,4	1,89	P	46,0	1,61			0,34	0,15	
3/4"	F VD34 L22	Female	809508028	20	4	M30X2	M42X2	G	122,5	4,82	F	81,9	3,23	L	14,0	0,55	B	36,0	1,42	K	22,0	0,87	M	41,8	1,65	Q	36,0	1,42	H	40,0	1,57	0,41	0,18
	M VD34 L22	Male	809508029								D	72,4	2,85										N	49,5	1,95	P	46,0	1,61			0,34	0,15	
1"	F VD100 L18	Female	809508030	25	6	M26X1.5	Rd 48X3 SP*	G	138,7	5,46	F	95,0	3,74	L	12,0	0,47	B	41,0	1,61	K	18,0	0,71	M	47,8	1,88	Q	41,0	1,61	H	45,0	1,77	0,70	0,32
	M VD100 L18	Male	809508031								D	78,5	3,09										N	60,0	2,36	P	55,0	2,16			0,59	0,27	
1"	F VD100 L22	Female	809508032	25	6	M30X2	Rd 48X3 SP*	G	142,7	5,62	F	97,0	3,82	L	14,0	0,55	B	41,0	1,61	K	22,2	0,87	M	47,8	1,88	Q	41,0	1,61	H	45,0	1,77	0,70	0,32
	M VD100 L22	Male	809508033								D	80,5	3,17										N	60,0	2,36	P	55,0	2,16			0,60	0,27	
1"	F VD100 L28	Female	809508034	25	6	M36X2	Rd 48X3 SP*	G	142,7	5,62	F	97,0	3,82	L	14,0	0,55	B	41,0	1,61	K	28,2	1,11	M	47,8	1,88	Q	41,0	1,61	H	45,0	1,77	0,70	0,32
	M VD100 L28	Male	809508035								D	80,5	3,17										N	60,0	2,36	P	55,0	2,16			0,60	0,27	
1"	F VD100 L35	Female	809508036	25	6	M45X2	Rd 48X3 SP*	G	146,7	5,78	F	99,0	3,90	L	16,0	0,63	B	46,0	1,81	K	35,3	1,39	M	47,8	1,88	Q	41,0	1,61	H	50,0	1,97	0,78	0,35
	M VD100 L35	Male	809508037								D	82,5	3,25										N	60,0	2,36	P	55,0	2,16			0,68	0,31	

* SP = SPECIAL THREAD

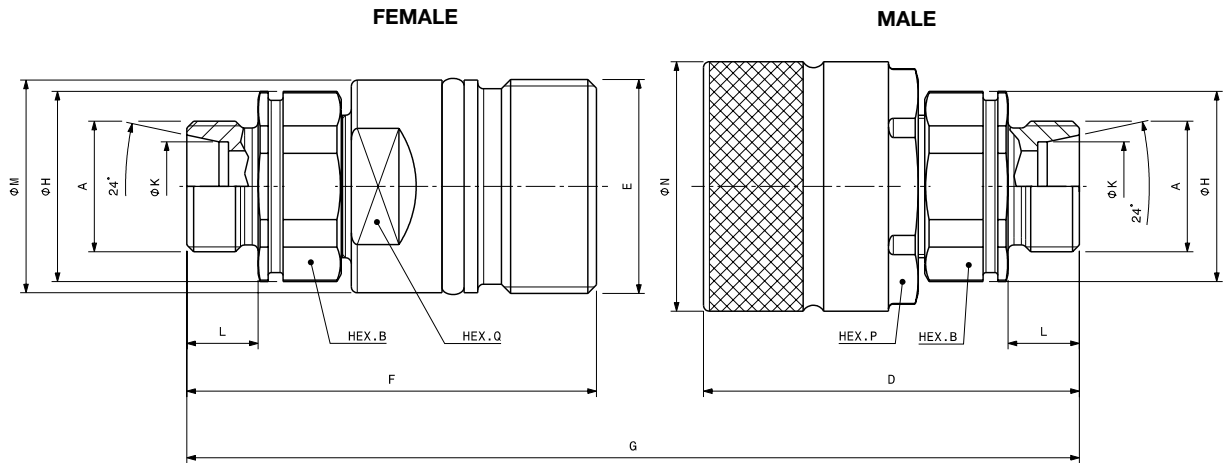

Port description: MALE THREAD METRIC S – 24° CONE (ISO 8434-1 & DIN 2353)

BODY SIZE	Descriptive Code	Item Code	ISO DN	BG	PORT (A)	E	Overall Length		Length		Length	Hex			Diameter		Hex		Diameter		Weight											
							mm	inch	mm	inch		mm	inch	mm	inch	mm	inch	mm	inch	mm	inch	mm	inch	Kg	Lbs							
3/8"	F VD38 S8	Female 809509012	10	2	M16X1.5	M28X2	G	97,0	3,82	F	63,3	2,49	L	12,0	0,47	B	22,0	0,87	K	8,0	0,31	M	27,8	1,09	Q	24,0	0,94	H	24,0	0,94	0,17	0,37
	M VD38 S8	Male 809509013								D	60,5	2,38				N	34,0	1,34	P	30,0	1,18	H	24,0	0,94	0,14	0,31						
3/8"	F VD38 S10	Female 809509008	10	3	M18X1.5	M28X2	G	97,0	3,82	F	63,3	2,49	L	12,0	0,47	B	22,0	0,87	K	10,0	0,39	M	27,8	1,09	Q	24,0	0,94	H	24,0	0,94	0,14	0,31
	M VD38 S10	Male 809509009								D	60,5	2,38				N	34,0	1,34	P	30,0	1,18	H	24,0	0,94	0,14	0,31						
1/2"	F VD12 S10	Female 809509000	12,5	3	M18X1.5	M36X2	G	104,6	4,12	F	69,0	2,72	L	12,0	0,47	B	30,0	1,18	K	10,0	0,39	M	35,8	1,41	Q	30,0	1,18	H	32,0	1,26	0,26	0,58
	M VD12 S10	Male 809509001								D	63,3	2,49				N	42,0	1,65	P	36,0	1,42	H	32,0	1,26	0,22	0,47						
1/2"	F VD12 S12	Female 809509002	12,5	3	M20X1.5	M36X2	G	103,6	4,08	F	69,0	2,72	L	12,0	0,47	B	30,0	1,18	K	12,0	0,47	M	35,8	1,41	Q	30,0	1,18	H	32,0	1,26	0,26	0,58
	M VD12 S12	Male 809509003								D	63,3	2,49				N	42,0	1,65	P	36,0	1,42	H	32,0	1,26	0,21	0,47						
1/2"	F VD12 S14	Female 809509004	12,5	3	M22X1.5	M36X2	G	-	-	F	71,0	2,80	L	14,0	0,55	B	30,0	1,18	K	14,0	0,55	M	35,8	1,41	Q	30,0	1,18	H	32,0	1,26	0,26	0,58
	M VD12 S14	Male 809509005								D	65,3	2,57				N	42,0	1,65	P	36,0	1,42	H	32,0	1,26	0,22	0,47						
1/2"	F VD12 S16	Female 809509006	12,5	3	M24X1.5	M36X2	G	108,6	4,28	F	71,0	2,80	L	14,0	0,55	B	30,0	1,18	K	16,0	0,63	M	35,8	1,41	Q	30,0	1,18	H	32,0	1,26	0,30	0,66
	M VD12 S16	Male 809509007								D	65,3	2,57				N	42,0	1,65	P	36,0	1,42	H	32,0	1,26	0,26	0,57						
3/4"	F VD34 S16	Female 809509014	20	4	M24X1,5	M42X2	G	122,5	4,82	F	81,9	3,22	L	14,0	0,55	B	36,0	1,42	K	16,0	0,63	M	41,8	1,65	Q	36,0	1,42	H	40,0	1,57	0,41	0,89
	M VD34 S16	Male 809509015								D	72,4	2,85				N	48,0	1,89	P	46,0	1,81	H	40,0	1,57	0,34	0,75						
3/4"	F VD34 S20	Female 809509016	20	4	M30X2	M42X2	G	126,5	4,98	F	83,9	3,30	L	16,0	0,63	B	36,0	1,42	K	20,0	0,79	M	41,8	1,65	Q	36,0	1,42	H	40,0	1,57	0,41	0,90
	M VD34 S20	Male 809509017								D	74,4	2,92				N	48,0	1,89	P	46,0	1,81	H	40,0	1,57	0,34	0,75						
1"	F VD100 S20	Female 809509018	25	6	M30X2	48X3 SP*	G	-	-	F	99,0	3,90	L	16,0	0,63	B	41,0	1,61	K	20,2	0,80	M	47,8	1,88	Q	41,0	1,61	H	45,0	1,77	0,72	1,58
	M VD100 S20	Male 809509019								D	82,5	3,25				N	60,0	2,36	P	55,0	2,16	H	45,0	1,77	0,61	1,34						
1"	F VD100 S25	Female 809509020	25	6	M36X2	48X3 SP*	G	150,7	5,93	F	101,0	3,98	L	18,0	0,71	B	41,0	1,61	K	25,2	0,99	M	47,8	1,88	Q	41,0	1,61	H	45,0	1,77	0,74	1,62
	M VD100 S25	Male 809509021								D	84,5	3,33				N	60,0	2,36	P	55,0	2,16	H	45,0	1,77	0,63	1,39						
1"	F VD100 S30	Female 809509022	25	6	M42X2	48X3 SP*	G	154,7	6,09	F	103,0	4,06	L	20,0	0,79	B	46,0	1,81	K	30,2	1,19	M	47,8	1,88	Q	41,0	1,61	H	50,0	1,97	0,81	1,79
	M VD100 S30	Male 809509023								D	86,5	3,41				N	60,0	2,17	P	55,0	2,16	H	50,0	1,97	0,71	1,57						
1-1/4"	F VD114 S30	Female 809509026	31,5	8	M42X2	70X3 SP*	G	183,0	7,20	F	114,2	4,50	L	20,0	0,79	B	55,0	2,17	K	30,2	1,19	M	68,5	2,70	Q	65,0	2,56	H	61,0	2,40	1,59	3,50
	M VD114 S30	Male 809509027								D	118,0	4,65				N	65 CH80**	3,15-3,15,15"	P	80,0	3,15	H	61,0	2,40	2,36	5,19						
1-1/4"	F VD114 S38	Female 809509028	31,5	8	M52X2	70X3 SP*	G	187,0	7,36	F	116,2	4,57	L	22,0	0,87	B	55,0	2,17	K	38,3	1,51	M	68,5	2,70	Q	65,0	2,56	H	61,0	2,40	1,63	3,59
	M VD114 S38	Male 809509029								D	120,0	4,72				N	65 CH80**	3,15-3,15,15"	P	80,0	3,15	H	61,0	2,40	2,41	5,31						

*SP = SPECIAL THREAD
**HEXAGON SLEEVE

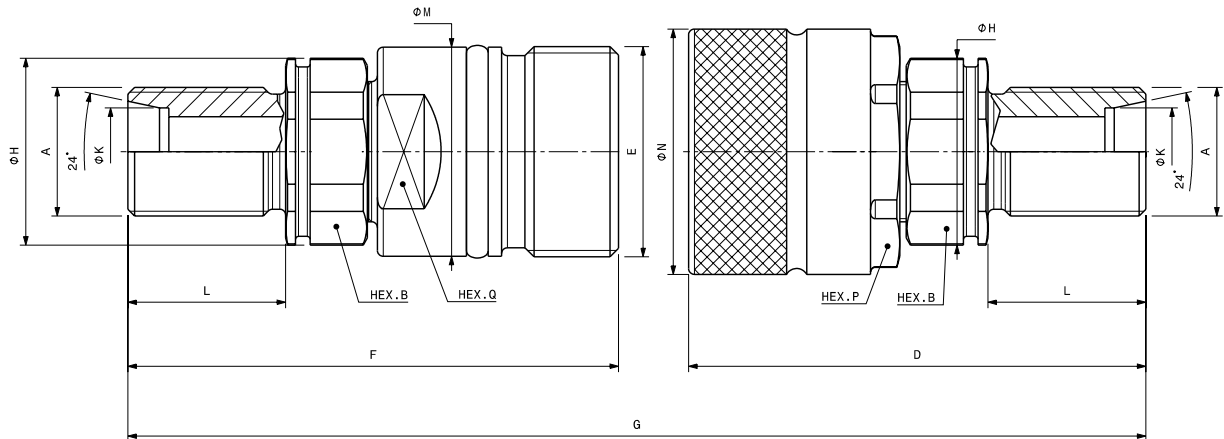
FEMALE
MALE

Port description: MALE THREAD METRIC L SCHOTT – 24° CONE BULKHEAD (ISO 8434-1 & DIN 2353)

BODY SIZE	Descriptive Code	Item Code	ISO DN	BG	PORT (A)	E	Overall Length		Length		Hex			Diameter		Hex		Diameter		Weight										
							mm	inch	mm	inch	mm	inch	mm	inch	mm	inch	mm	inch	mm	inch	Kg	Lbs								
1/4"	F VD14 L8 SCHOTT	Female 809510012 *	6,3	1	M14X1.5	M24X2	G	-	-	F	74,7	2,94	L	25,0	0,98	B	19,0	0,75	K	M	23,8	0,94	Q	22,0	0,87	H	21,0	0,83	-	-
	M	VD14 L8 SCHOTT								Male 809510013 *	D	-											-	N						
3/8"	F VD38 L8 SCHOTT	Female 809510014	10	2	M14X1.5	M28X2	G	-	-	F	76,3	3,00	L	25,0	0,98	B	22,0	0,87	K	M	27,8	1,09	Q	24,0	0,94	H	24,0	0,94	0,14	0,31
	M	VD38 L8 SCHOTT								Male 809510015	D	73,5											2,89	N						
3/8"	F VD38 L10 SCHOTT	Female 809510016	10	2	M16X1.5	M28X2	G	125,0	4,92	F	77,3	3,04	L	26,0	1,02	B	22,0	0,87	K	M	27,8	1,09	Q	24,0	0,94	H	24,0	0,94	0,17	0,37
	M	VD38 L10 SCHOTT						Male 809510017	D	74,5	2,93	N											34,0	1,34						
1/2"	F VD12 L10 SCHOTT	Female 809510006	12,5	3	M16X1.5	M36X2	G	132,6	5,22	F	83,0	3,27	L	26,0	1,02	B	30,0	1,18	K	M	35,8	1,41	Q	30,0	1,18	H	32,0	1,26	0,32	0,69
	M	VD12 L10 SCHOTT						Male 809510007	D	77,3	3,04	N											42,0	1,65						
1/2"	F VD12 L12 SCHOTT	Female 809510000	12,5	3	M18X1.5	M36X2	G	140,6	5,54	F	87,0	3,43	L	30,0	1,18	B	30,0	1,18	K	M	35,8	1,41	Q	30,0	1,18	H	32,0	1,26	0,27	0,58
	M	VD12 L12 SCHOTT						Male 809510001	D	81,3	3,20	N											42,0	1,65						
1/2"	F VD12 L15 SCHOTT	Female 809510004	12,5	3	M22X1.5	M36X2	G	134,6	5,30	F	84,0	3,31	L	27,0	1,06	B	30,0	1,18	K	M	35,8	1,41	Q	30,0	1,18	H	32,0	1,26	0,27	0,59
	M	VD12 L15 SCHOTT						Male 809510005	D	78,3	3,08	N											42,0	1,65						
1/2"	F VD12 L18 SCHOTT	Female 809510008	12,5	3	M26X1.5	M36X2	G	134,6	5,30	F	84,0	3,31	L	27,0	1,06	B	30,0	1,18	K	M	35,8	1,41	Q	30,0	1,18	H	32,0	1,26	0,27	0,60
	M	VD12 L18 SCHOTT						Male 809510009	D	78,3	3,08	N											42,0	1,65						
3/4"	F VD34 L15 SCHOTT	Female 809510024	20	4	M22X1.5	M42X2	G	148,5	5,85	F	94,9	3,74	L	27,0	1,06	B	36,0	1,42	K	M	41,8	1,65	Q	36,0	1,42	H	40,0	1,57	0,41	0,90
	M	VD34 L15 SCHOTT						Male 809510025	D	85,4	3,36	N											49,5	1,95						
3/4"	F VD34 L18 SCHOTT	Female 809510026	20	4	M26X1.5	M42X2	G	150,5	5,93	F	95,9	3,77	L	27,0	1,06	B	36,0	1,42	K	M	41,8	1,65	Q	36,0	1,42	H	40,0	1,57	0,41	0,91
	M	VD34 L18 SCHOTT						Male 809510027	D	86,4	3,40	N											49,5	1,95						
3/4"	F VD34 L22 SCHOTT 36	Female 809510028	20	4	M30X2	M42X2	G	-	-	F	103,9	4,09	L	36,0	1,42	B	36,0	1,42	K	M	41,8	1,65	Q	36,0	1,42	H	40,0	1,57	0,42	0,91
	M	VD34 L22 SCHOTT 36						Male 809510029 *	D	94,4	3,72	N											49,5	1,95						
1"	F VD100 L18 SCHOTT 32	Female 809510030	25	6	M26X1,5	48X3 SP*	G	178,7	7,04	F	115,0	4,53	L	32,0	1,26	B	41,0	1,61	K	M	47,8	1,88	Q	41,0	1,61	H	45,0	1,77	0,74	1,63
	M	VD100 L18 SCHOTT 32						Male 809510031	D	98,5	3,88	N											60,0	2,36						
1"	F VD100 L22 SCHOTT 32	Female 809510032	25	6	M30X2	48X3 SP*	G	182,7	7,19	F	117,0	4,61	L	34,0	1,34	B	41,0	1,61	K	M	47,8	1,88	Q	41,0	1,61	H	45,0	1,77	0,76	1,66
	M	VD100 L22 SCHOTT 32						Male 809510033	D	100,5	3,96	N											60,0	2,36						
1"	F VD100 L28 SCHOTT	Female 809510034	25	6	M36X2	48X3 SP*	G	182,7	7,19	F	117,0	4,61	L	34,0	1,34	B	41,0	1,61	K	M	47,8	1,88	Q	41,0	1,61	H	45,0	1,77	0,78	1,71
	M	VD100 L28 SCHOTT						Male 809510035	D	100,5	3,96	N											60,0	2,36						

* Available upon request.

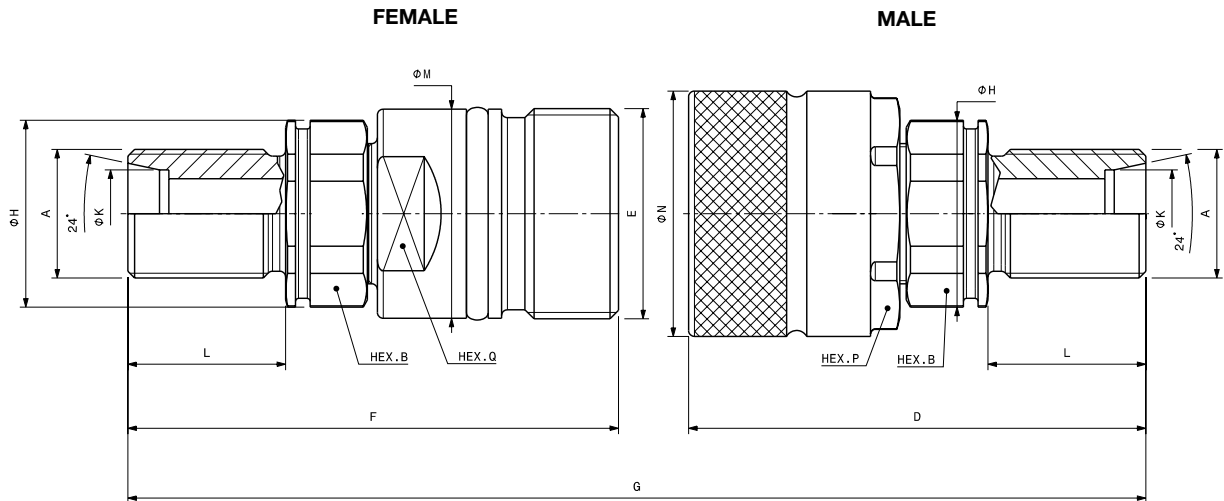
* SP = SPECIAL THREAD



Port description: MALE THREAD METRIC S SCHOTT – 24° CONE BULKHEAD (ISO 8434-1 & DIN 8353)

BODY SIZE	Descriptive Code	Item Code	ISO DN	BG	PORT (A)	E	Overall Length		Length		Diameter		Wrench Flat		Diameter		Diameter		Hex		Diameter		Weight										
							mm	inch	mm	inch	mm	inch	mm	inch	mm	inch	mm	inch	mm	inch	mm	inch	mm	inch	Kg	Lbs							
3/8"	F VD38 S12 SCHOTT	Female	809511010	10	2	M20X1.5	M28X2	G	-	-	F	78,3	3,08	L	27	1,06	B	22,0	0,87	K	12,0	0,47	M	-	-	Q	-	-	H	24,0	0,94	0,15	0,32
	M VD38 S12 SCHOTT	Male	809511011								D	75,5	2,97								N	34,0	1,34	P	30,0	1,18			H			0,32	0,71
1/2"	F VD12 S10 SCHOTT	Female	809511000	12,5	3	M18X1.5	M36X2	G	134,6	5,30	F	84,0	3,31	L	27	1,06	B	30,0	1,18	K	10,0	0,39	M	35,8	1,41	Q	30,0	1,18	H	32,0	1,26	0,27	0,59
	M VD12 S10 SCHOTT	Male	809511001								D	78,3	3,08								N	42,0	1,65	P	36,0	1,42			H			0,59	1,30
1/2"	F VD12 S12 SCHOTT	Female	809511002	12,5	3	M20X1.5	M36X2	G	134,6	5,30	F	84,0	3,31	L	27	1,06	B	30,0	1,18	K	12,0	0,47	M	35,8	1,41	Q	30,0	1,18	H	32,0	1,26	0,27	0,59
	M VD12 S12 SCHOTT	Male	809511003								D	78,3	3,08								N	42,0	1,65	P	36,0	1,42			H			0,59	1,30
1/2"	F VD12 S16 SCHOTT	Female	809511006	12,5	3	M24X1.5	M36X2	G	138,6	5,46	F	86,0	3,39	L	29	1,14	B	30,0	1,18	K	16,0	0,63	M	35,8	1,41	Q	30,0	1,18	H	32,0	1,26	0,27	0,60
	M VD12 S16 SCHOTT	Male	809511007								D	80,3	3,16								N	42,0	1,65	P	36,0	1,42			H			0,60	1,31
3/4"	F VD34 S16 SCHOTT	Female	809511014*	20	4	M24X1.5	M42X2	G	-	-	F	96,9	3,81	L	29	1,14	B	36,0	1,42	K	16,2	0,64	M	41,0	1,65	Q	36,0	1,42	H	40,0	1,57	0,41	0,90
	M VD34 S16 SCHOTT	Male	809511015*								D	-	-								N	-	-	P	-	-			H			0,90	1,99
3/4"	F VD34 S20 SCHOTT	Female	809511016	20	4	M30X2	M42X2	G	166,5	6,56	F	103,9	4,09	L	36	1,42	B	36,0	1,42	K	20,0	0,79	M	41,8	1,65	Q	36,0	1,42	H	40,0	1,57	0,42	0,92
	M VD34 S20 SCHOTT	Male	809511017								D	94,4	3,72								N	49,5	1,90	P	46,0	1,81			H			0,92	2,03
1"	F VD100 S20 SCHOTT	Female	809511018	25	6	M30X2	48X3 SP*	G	190,7	7,51	F	121,0	4,76	L	38	1,50	B	41,0	1,61	K	20,2	0,80	M	47,8	1,88	Q	41,0	1,61	H	45,0	1,77	0,69	1,51
	M VD100 S20 SCHOTT	Male	809511019								D	104,5	4,11								N	60,0	2,36	P	55,0	2,16			H			1,51	3,33
1"	F VD100 S25 SCHOTT	Female	809511020	25	6	M36X2	48X3 SP*	G	190,7	7,51	F	121,0	4,76	L	38	1,50	B	41,0	1,61	K	25,2	0,99	M	47,8	1,88	Q	41,0	1,61	H	45,0	1,77	0,83	1,83
	M VD100 S25 SCHOTT	Male	809511021								D	104,5	4,11								N	60,0	2,36	P	55,0	2,16			H			1,83	4,03
1"	F VD100 S30 SCHOTT	Female	809511022	25	6	M42X2	48X3 SP*	G	194,7	7,67	F	123,0	4,84	L	40	1,57	B	46,0	1,81	K	30,2	1,19	M	47,8	1,88	Q	41,0	1,61	H	50,0	1,97	0,94	2,06
	M VD100 S30 SCHOTT	Male	809511023								D	106,5	4,19								N	60,0	2,36	P	55,0	2,16			H			2,06	4,54
1"	F VD100 S38 SCHOTT	Female	809511024*	25	6	M52X2	48X3 SP*	G	-	-	F	123,0	4,84	L	40	1,57	B	55,0	2,17	K	38,3	1,51	M	47,8	1,88	Q	41,0	1,61	H	60,0	2,36	1,16	2,55
	M VD100 S38 SCHOTT	Male	809511025*								D	-	-								N	-	-	P	-	-			H			2,55	5,61

*SP = SPECIAL THREAD

*Available upon request.



SPARE KIT SEAL FOR FEMALE

Repair kit / OR+BK		
Body Size	Description	Part Number
1/4"	FVD14	815700900
3/8"	FVD38	815701151
1/2"	FVD12	815700904
3/4"	FVD34	815700906
1"	FVD100	815700908
1-1/4"	FVD114	815700910

O-Ring in NBR
BackUp in Teflon®

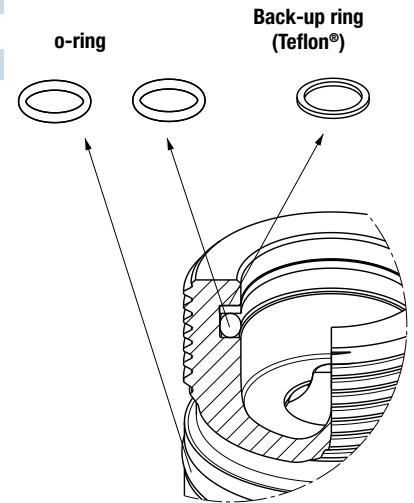

PROTECTIVE CAPS FOR VD SERIES

Protective caps are always recommended to protect the couplings from damage, dirt inclusion, and will increase the product life. This is particularly important in mobile applications where exposure to weather and aggregate materials are common. The protective caps for VD couplings are manufactured in plastic with connection lanyard (standard color red).

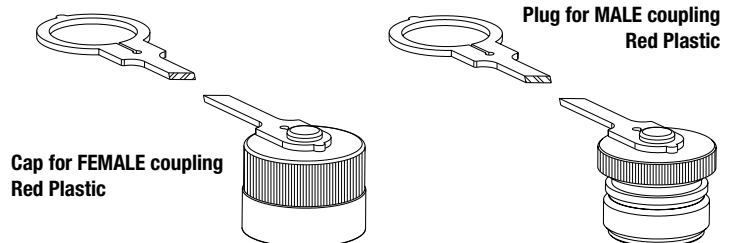

Body Size/Description	Protective Cap		Material/Color
	Cap for Female	Plug for Male	
1/4" VD14	814900000	814900001	Plastic/Red
3/8" VD38	814900002	814900003	Plastic/Red
1/2" VD12	814900004	814900005	Plastic/Red
3/4" VD34	814900006	814900007	Plastic/Red
1" VD100	814900016	814900017	Plastic/Red
1-1/4" VD114	814900018	814900019	Plastic/Red















VLSSERIES

INTERCHANGE > Similar Couplings



TECHNICAL FEATURES AND OPTIONS

 Interchange Similar Couplings	 Sealing description Nitrile NBR	 Connection system Screw
 Available sizes from 1/2" to 1"	 Material/treatment Carbon steel /Cr3	 Available threads BSP - METRIC
 Operating pressure Up to 465 bar	 Locking mechanism Screw to connect	 Flow rate Up to 200 l/min
 Temperature (°C) -20° / +100°	 Valving style Poppet	 Connection under pressure Connection: one side Disconnection: not allowed

BENEFITS

- Connection is allowed in one half of the coupling up to 10 MPa.
- Robustness and ease of construction.
- Shape of internal parts is designed to reduce turbulence and pressure drop.
- The robust construction makes them suitable for heavy duty applications.
- Good resistance to pressure impulses.
- Compact design.
- Simple to use.

HOW TO USE

- Before to connect, clean the mating surface of the couplings to avoid dirt inclusion in the circuit.
- To connect insert the male coupling in the female coupling, screw the sleeve till its stop, do not push together the couplings, screw only.
- The use of tools for the second part of the connection can be necessary if there is high residual pressure in the circuit.
- To disconnect unscrew totally the sleeve from the female coupling.

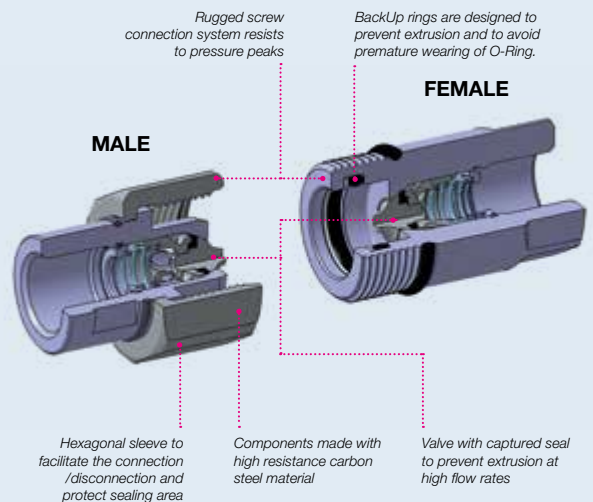
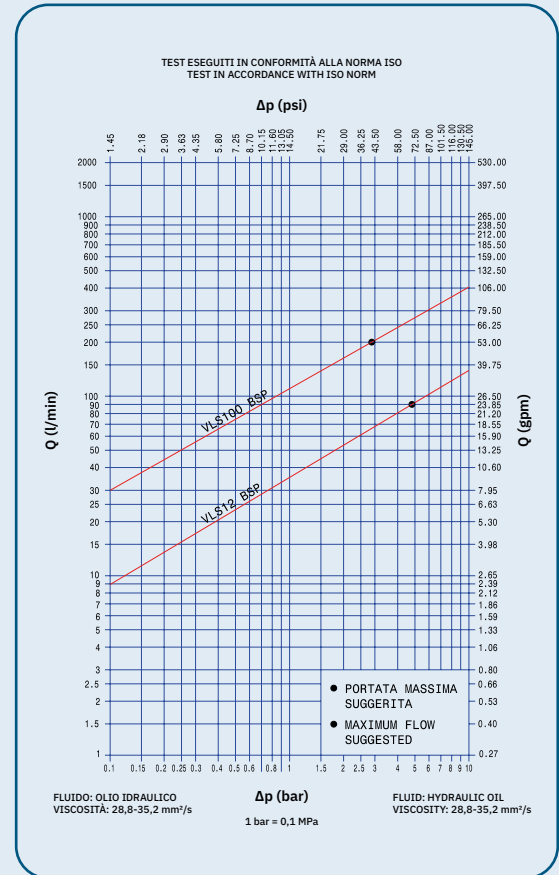

MAIN APPLICATIONS

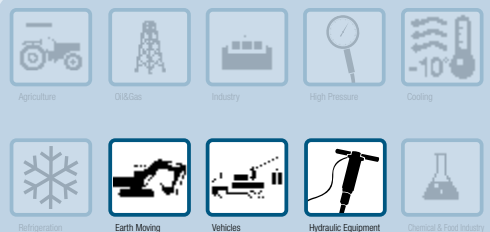

POPET SCREW



PERFORMANCES

Size		Series/Size	Max. flow suggested		Manual connect torque*		Manual disconnect torque*		Spillage**
Inch	mm		l/min	gpm	Nm	lbf ft	Nm	lbf ft	ml
1/2	12,5	VLS12	90	23,85	3,2	2,36	3,2	2,36	2,5
1	25,0	VLS100	200	53,00	1,3	0,96	0,6	0,44	15

Size	Series/Size	Max. operating pressure						Burst pressure					
		Coupled		Male		Female		Coupled		Male		Female	
Inch		MPa	psi	MPa	psi	MPa	psi	MPa	psi	MPa	psi	MPa	psi
1/2	VLS12	46,5	6743	46,5	6743	46,5	6743	200	29000	130	18850	170	24650
1	VLS100	46,5	6743	46,5	6743	46,5	6743	140	20300	140	20300	140	20300

* Connect torque and disconnect torque without residual pressure.

The torque will increase as internal residual pressure increases.

** Spillage is an indicative value of the fluid loss during disconnection (according to ISO norm test method).

Temperature range:

Standard seals NBR (Nitrile): from -20 °C to +100 °C (from -4 °F to +212 °F). Please read carefully Instructions and warnings for proper selection of the products.

Tests performed:

The couplings have been tested at maximum operating pressure for 1,000,000 impulses according to ISO norm test method.



WARNING

A defect, a wrong choice or an improper use of products, can cause injury to persons, animals and objects.

Never connect or disconnect with dynamic pressure (e.g. pump on).

Do not couple-uncouple with flow in the circuit.

Do not couple-uncouple when the temperature inside of the circuit is higher than 80 °C (176 °F).

Do not use the coupling disconnected with high impulse pressure.

Connect under pressure products are suitable to be connected under residual (static) pressure.

Connection with residual pressure (pressure trapped in the circuit) allowed with other side coupling to drain.

Check the maximum allowable working pressure of the port in use.

Make sure that the medium used is compatible with seal and material as indicated for each series.

In case of doubt please contact Stucchi Technical Support.

The interchangeability is mentioned under the assumption that the manufacturer of the considered products has not changed any dimension.

It is mandatory to carefully read and closely follow the instructions before selecting or using any Stucchi products.

Always refer to the version uploaded in the Instructions and warning section of stucchigroup.com website for the latest release.

For specific, product-related, instructions, please contact Stucchi technical service.

OVERALL DIMENSIONS

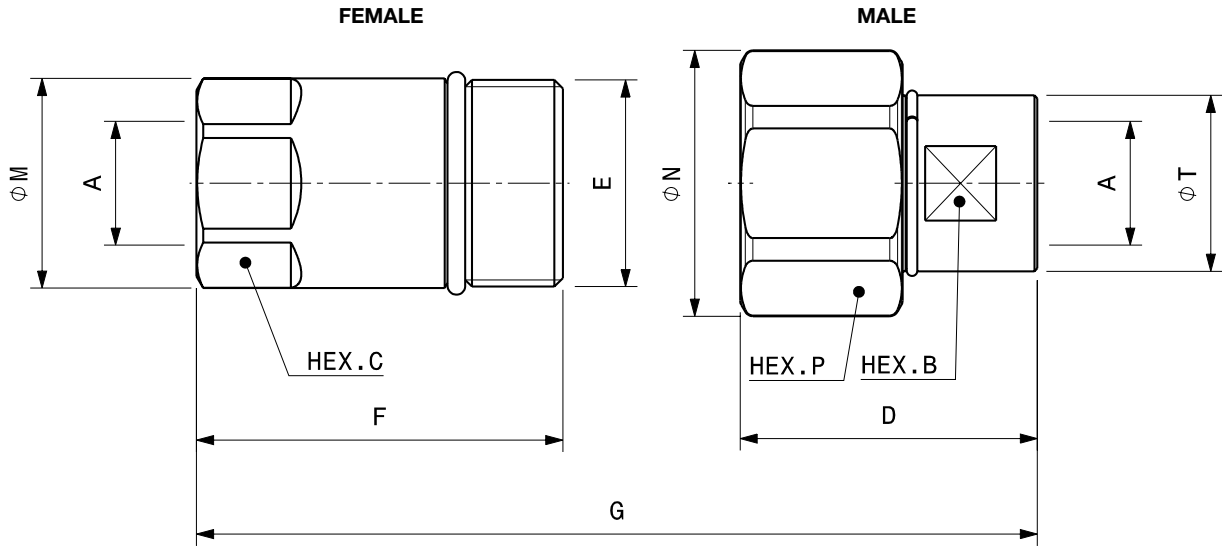

Port description: FEMALE THREAD BSPP (ISO 1179-1)

BODY SIZE	Descriptive Code	Item Code	DN	PORT (A)	E	Overall Length		Length		Hex		Diameter		Hex		Diameter		Weight							
						mm	inch	mm	inch	mm	inch	mm	inch	mm	inch	mm	inch	Kg	Lbs						
1/2"	F VLS12 BSP	Female 809900004	12,5	1/2"	35X2 SP*	G	92,6	3,65	F	62,0	2,44	B	35,5	1,40	M	35,5	1,40	C	32,0	1,26	T	29,8	1,17	0,32	0,69
	M VLS12 BSP	Male 809900005							D	50,3	1,98	N	45,0	1,77	P	41,0	1,61								
1"	F VLS100 BSP	Female 809900008	25	1"	54X3 SP*	G	143	5,63	F	101,5	4,00	B	44,0	1,73	M	50,0	1,97	C	46,0	1,81	T	54,0	2,13	0,88	1,94
	M VLS100 BSP	Male 809900009							D	66,9	2,63	N	72,0	2,83	P	65,0	2,56								

Port description: FEMALE THREAD METRIC

BODY SIZE	Descriptive Code	Item Code	ISO	PORT (A)	E	Overall Length		Length		Hex		Diameter		Hex		Diameter		Weight							
						mm	inch	mm	inch	mm	inch	mm	inch	mm	inch	mm	inch	Kg	Lbs						
1/2"	F VLS12 M22x1,5 ISO	Female 809912004	12,5	M22X1,5	35X2 SP*	G	92,6	3,65	F	62,0	2,44	B	27,0	1,06	M	35,5	1,40	C	32,0	1,26	T	29,8	1,17	0,31	0,67
	M VLS12 M22x1,5 ISO	Male 809912005							D	50,3	1,98	N	45,0	1,77	P	41,0	1,61								
1"	F VLS100 M30x1,5 ISO	Female 809912008	25	M30X1,5	54X3 SP*	G	143,0	5,63	F	101,5	4,00	B	41,0	1,61	M	50,0	1,97	C	46,0	1,81	T	54,0	2,13	0,90	1,98
	M VLS100 M30x1,5 ISO	Male 809912009							D	66,9	2,63	N	72,0	2,83	P	65,0	2,56								

*SP = SPECIAL THREAD



SPARE KIT SEAL FOR FEMALE

Repair kit / OR+BK		
Body Size	Description	Part Number
1/2"	FVLS12	815700920
1"	FVLS100	815700922

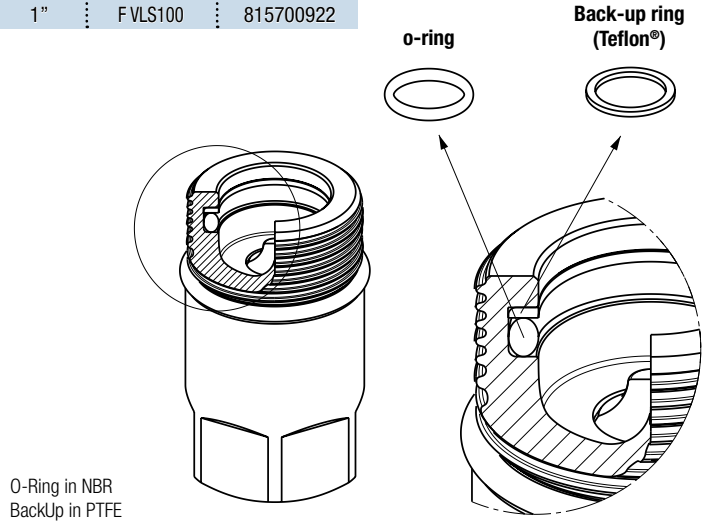

PROTECTIVE CAPS FOR VLS SERIES

Protective caps are always recommended to protect the couplings from damage, dirt inclusion, and will increase the product life. This is particularly important in mobile applications where exposure to weather and aggregate materials are common.

For the VLS series, aluminum screw caps complete with lanyard are available (colors: natural aluminum).

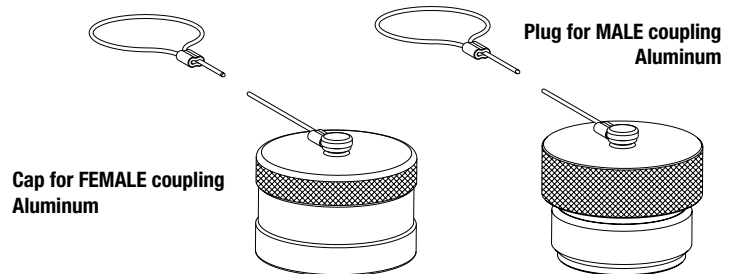

Body Size/Description		Protective Cap		Material/Color
		Part Number	Part Number	
1/2"	VLS12	Cap for Female	Plug for Male	Aluminum/Natural
		814906022	814906023	
1"	VLS100	814906024	814906025	Aluminum/Natural



VOF SERIES

INTERCHANGE > Similar Couplings (Oil & Gas)



BOP



TECHNICAL FEATURES AND OPTIONS

Interchange Similar Couplings (Oil & Gas)	Sealing description Nitrile NBR	Connection system Screw
Available sizes From 3/4" to 2"	Material/treatment Carbon steel /Cr3	Available threads BSP - NPT - SAE
Operating pressure Up to 345 bar	Locking mechanism Screw to connect	Flow rate Up to 1100 l/min
Temperature (°C) -20° / +100°	Valving style Poppet	Connection under pressure Connection: one side Disconnection: not allowed

BENEFITS

- Connection under residual pressure is allowed in one side.
- Inspection hole to control if the coupling is completely connected.
- All dimensions of Stucchi VOF series are certified with Lloyd Type Approval in accordance with API 16D at specific rating pressure of 345 bar/5000 psi for all sizes except size 2" that is 333 bar/4830 psi.
- Wrench flat on the bodies to facilitate the fitting assembly.
- The poppet valve with elastomer seal provides maximum sealing of the couplings when disconnected.
- Retainer in high resistance carbon steel.
- Shape of internal parts is designed to reduce turbulence and pressure drop.
- High resistance to pressure impulses (500.000 connected).
- Compact design.
- Simple to use.

HOW TO USE

- Before to connect, clean the mating surface of the couplings to avoid dirt inclusion in the circuit.
- To connect insert the nipple in the coupler, screw the sleeve until positive stop (surface contact of two moving parts), do not push together the couplings, screw only.
- The use of tools for the second part of the connection can be necessary if there is high residual pressure in the circuit.
- Check inspection holes to ensure that the coupling is fully connected (no free space allowed).
- To disconnect unscrew totally the sleeve from the nipple.

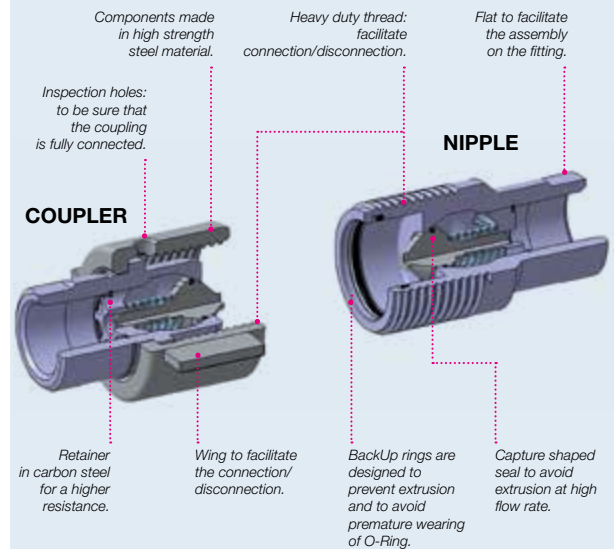
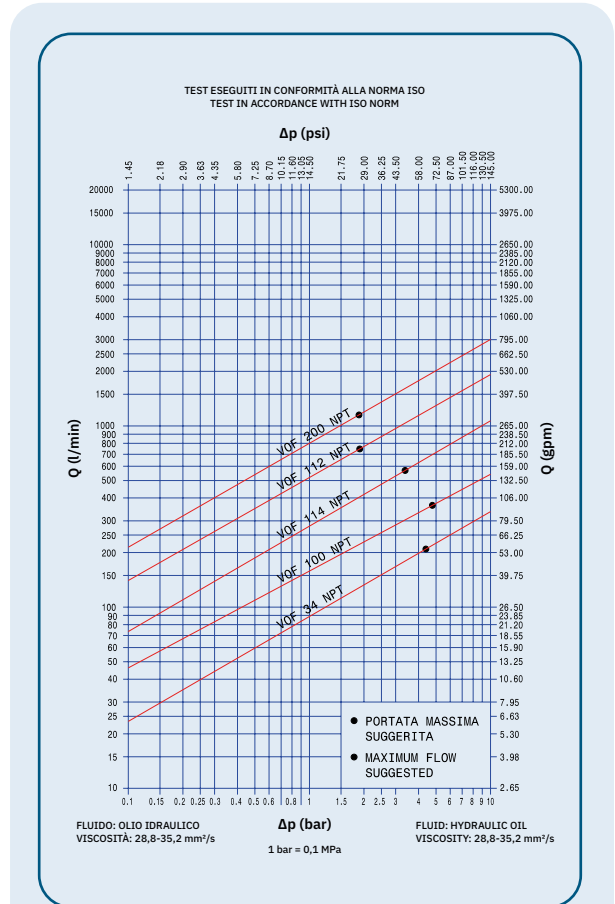

MAIN APPLICATIONS



POPET SCREW

PERFORMANCES

Size		Series/Size	Max. flow suggested		Manual connect torque*		Manual disconnect torque*		Spillage**
Inch	mm		l/min	gpm	Nm	lbf ft	Nm	lbf ft	ml
3/4"	20	VOF34	212	56,18	1,2	0,89	0,6	0,44	11,5
1"	25	VOF100	378	100,17	1,6	1,18	1,1	0,81	21,2
1-1/4"	31,5	VOF114	576	152,64	2,8	2,07	1,9	1,40	42,3
1-1/2"	40	VOF112	758	200,87	4	2,95	3,6	2,66	82,6
2"	50	VOF200	1100	291,50	7,5	5,53	5,1	3,76	192,0

Size	Series/Size	Max. operating pressure						Burst pressure					
		Coupled		Nipple		Coupler		Coupled		Nipple		Coupler	
Inch		MPa	psi	MPa	psi	MPa	psi	MPa	psi	MPa	psi	MPa	psi
3/4"	VOF34	34,5	5000	34,5	5000	34,5	5000	137,9	20000	137,9	20000	100,0	14500
1"	VOF100	34,5	5000	34,5	5000	34,5	5000	137,9	20000	137,9	20000	100,0	14500
1-1/4"	VOF114	34,5	5000	34,5	5000	34,5	5000	137,9	20000	137,9	20000	100,0	14500
1-1/2"	VOF112	34,5	5000	34,5	5000	34,5	5000	137,9	20000	137,9	20000	82,8	12000
2"	VOF200	34,5	5000	34,5	5000	34,5	5000	100,0	14500	90,0	13050	75,9	11000

* Connect torque and disconnect torque without residual pressure.

The torque will increase as internal residual pressure increases.

** Spillage is an indicative value of the fluid loss during disconnection (according to ISO norm test method).

All dimensions of Stucchi VOF series are certified with Lloyd Type. Approval in accordance with API 16D at specific rating pressure of 345 bar/5000 psi for all sizes except size 2" that is 333 bar/4830 psi. For complete technical information please contact Stucchi Technical Support.

Different possible configurations:

SAE thread available upon request.

Temperature range:

Standard seals NBR from -20 °C to +100 °C (from -4 °F to +212 °F).

Please read carefully Instructions and warnings for proper selection of the products.

Tests performed:

The connected couplings have been tested at maximum operating pressure for 500.000 impulses in according to ISO norm.

The couplings disconnected have been tested for 100.000 impulses.

⚠ WARNING

A defect, a wrong choice or an improper use of products, can cause injury to persons, animals and objects.

Never connect or disconnect with dynamic pressure (e.g. pump on).

Do not couple-uncouple with flow in the circuit.

Do not couple-uncouple when the temperature inside of the circuit is higher than 80 °C (176 °F).

Do not use the coupling disconnected with high impulse pressure.

Connect under pressure products are suitable to be connected under residual (static) pressure.

Connection with residual pressure (pressure trapped in the circuit) allowed with other side coupling to drain.

Check the maximum allowable working pressure of the port in use.

Make sure that the medium used is compatible with seal and material as indicated for each series.

In case of doubt please contact Stucchi Technical Support.

The interchangeability is mentioned under the assumption that the manufacturer of the considered products has not changed any dimension.

It is mandatory to carefully read and closely follow the instructions before selecting or using any Stucchi products.

Always refer to the version uploaded in the Instructions and warning section of stucchigroup.com website for the latest release.

For specific, product-related, instructions, please contact Stucchi technical service.

OVERALL DIMENSIONS

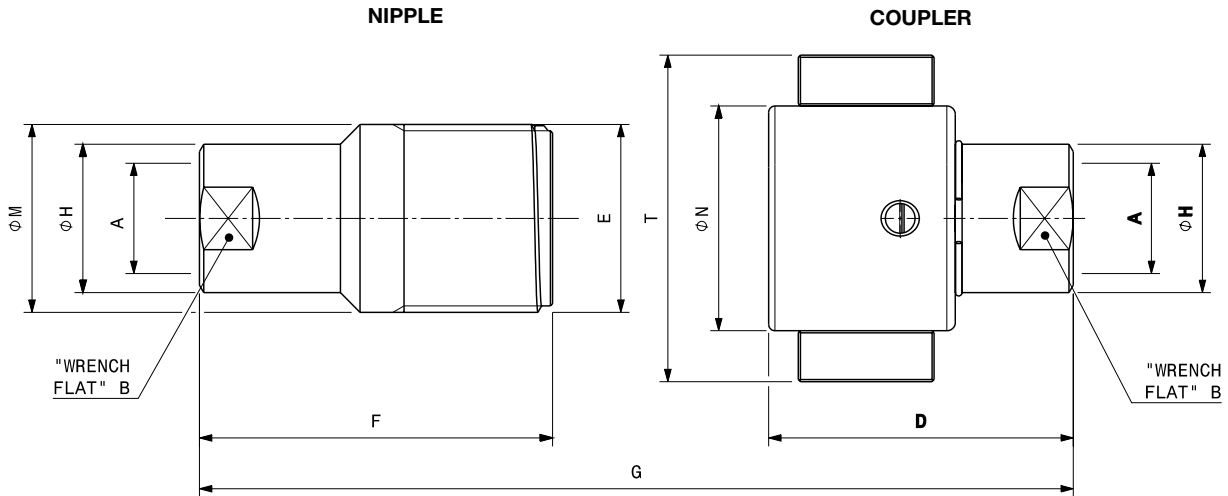

Port description: FEMALE THREAD NPT (ANSI B.1.20.1)

BODY SIZE	Descriptive Code	Item Code	PORT (A)	Thread	Overall Length		Length		Hex		Diameter						
					mm	inch	mm	inch	mm	inch	mm	inch					
3/4"	VOF34 NPT Nipple	811201002	3/4"	E	1 3/4-8 special	G	123,6	4,87	F	83,2	3,28	B	31,8	1,25	H	35,0	1,38
	VOF34 NPT Coupler	811201003							D	71,8	2,83						
1"	VOF100 NPT Nipple	811201000	1"	E	2 1/4-6 Stub ACME	G	152,9	6,02	F	105,8	4,17	B	41,3	1,63	H	45,0	1,77
	VOF100 NPT Coupler	811201001							D	87,3	3,44						
1-1/4"	VOF114 NPT Nipple	811201004	1-1/4"	E	2 5/8-6 Stub ACME	G	197,9	7,79	F	136,7	5,38	B	50,8	2,00	H	54,5	2,15
	VOF114 NPT Coupler	811201005							D	112,4	4,43						
1-1/2"	VOF112 NPT Nipple	811201006	1-1/2"	E	3 1/4-4 Stub ACME	G	220,3	8,67	F	151,2	5,95	B	57,2	2,25	H	63,5	2,50
	VOF112 NPT Coupler	811201007							D	126,9	5,00						
2"	VOF200 NPT Nipple	811201008	2"	E	4-4 Stub ACME	G	255,2	10,05	F	179,0	7,05	B	76,2	3,00	H	82,6	3,25
	VOF200 NPT Coupler	811201009							D	154,2	6,07						

BODY SIZE	Descriptive Code	Item Code	Diameter	Max overall dimension		Weight			
				mm	inch	mm	inch	Kg	Lbs
3/4"	VOF34 NPT Nipple	811201002	M	44,3	1,74			0,48	1,05
	VOF34 NPT Coupler	811201003	N	53,0	2,09	T	77,0	3,03	0,61
1"	VOF100 NPT Nipple	811201000	M	57,2	2,25			1,19	2,62
	VOF100 NPT Coupler	811201001	N	69,0	2,72	T	109,0	4,29	1,38
1-1/4"	VOF114 NPT Nipple	811201004	M	66,7	2,62			1,95	4,30
	VOF114 NPT Coupler	811201005	N	80,0	3,15	T	120,0	4,72	2,27
1-1/2"	VOF112 NPT Nipple	811201006	M	82,6	3,25			3,22	7,11
	VOF112 NPT Coupler	811201007	N	95,0	3,74	T	145,0	5,71	3,84
2"	VOF200 NPT Nipple	811201008	M	101,6	4,00			6,04	13,32
	VOF200 NPT Coupler	811201009	N	122,5	4,82	T	182,5	7,19	8,10

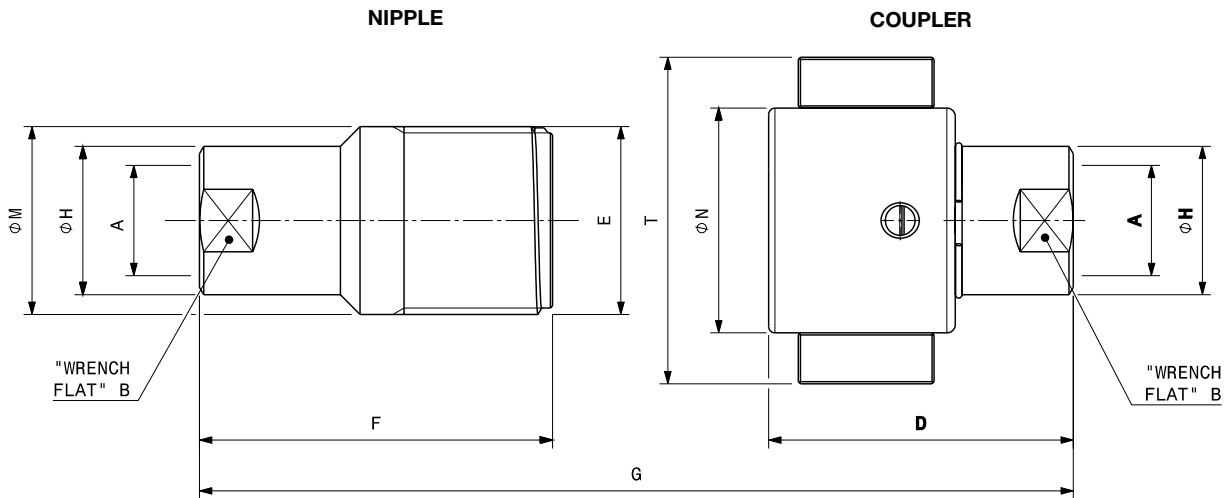

Port description: FEMALE THREAD BSPP (ISO 1179-1)

BODY SIZE	Descriptive Code	Item Code	PORT (A)	Thread	Overall Length	Length		Hex		Diameter							
						mm	inch	mm	inch	mm	inch						
3/4"	VOF34 BSP Nipple	811200002	3/4"	E	1 3/4-8 special	G	123,6	4,87	F	83,2	3,28	B	31,8	1,25	H	35,0	1,38
	VOF34 BSP Coupler	811200003							D	71,8	2,83						
1"	VOF100 BSP Nipple	811200000	1"	E	2 1/4-6 Stub ACME	G	152,9	6,02	F	105,8	4,17	B	41,3	1,63	H	45,0	1,77
	VOF100 BSP Coupler	811200001							D	87,3	3,44						
1-1/4"	VOF114 BSP Nipple	811200004	1-1/4"	E	2 5/8-6 Stub ACME	G	197,9	7,79	F	136,7	5,38	B	50,8	2,00	H	54,5	2,15
	VOF114 BSP Coupler	811200005							D	112,4	4,43						
1-1/2"	VOF112 BSP Nipple	811200006	1-1/2"	E	3 1/4-4 Stub ACME	G	220,3	8,67	F	151,2	5,95	B	57,2	2,25	H	63,5	2,50
	VOF112 BSP Coupler	811200007							D	126,9	5,00						
2"	VOF200 BSP Nipple	811200008	2"	E	4-4 Stub ACME	G	255,2	10,05	F	179,0	7,05	B	76,2	3,00	H	82,6	3,25
	VOF200 BSP Coupler	811200009							D	154,2	6,07						

BODY SIZE	Descriptive Code	Item Code	Diameter		Max overall dimension		Weight		
			mm	inch	mm	inch	Kg	Lbs	
3/4"	VOF34 BSP Nipple	811200002	M	44,30	1,74			0,50	1,10
	VOF34 BSP Coupler	811200003	N	53,00	2,09	T	77,0	3,03	0,63
1"	VOF100 BSP Nipple	811200000	M	57,15	2,25			1,17	2,58
	VOF100 BSP Coupler	811200001	N	69,00	2,72	T	109,0	4,29	1,35
1-1/4"	VOF114 BSP Nipple	811200004	M	66,67	2,62			1,92	4,23
	VOF114 BSP Coupler	811200005	N	80,00	3,15	T	120,0	4,72	2,24
1-1/2"	VOF112 BSP Nipple	811200006	M	82,55	3,25			3,16	6,97
	VOF112 BSP Coupler	811200007	N	95,00	3,74	T	145,0	5,71	3,82
2"	VOF200 BSP Nipple	811200008	M	101,60	4,00			6,03	13,29
	VOF200 BSP Coupler	811200009	N	122,50	4,82	T	182,5	7,19	8,09



SPARE KIT SEAL FOR NIPPLE

Repair kit / OR+BK		
Body Size	Description	Part Number
3/4"	VOF34	815700956
1"	VOF100	815700958
1-1/4"	VOF114	815700960
1-1/2"	VOF112	815701122
2"	VOF200	815700964

O-Ring in Nitrile
BackUp in Teflon®

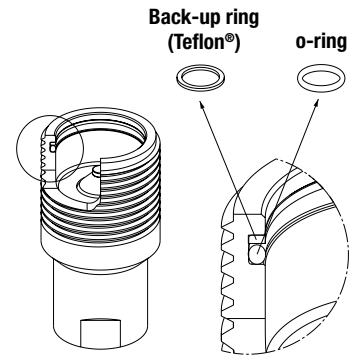

SPARE KIT INTERNAL PARTS

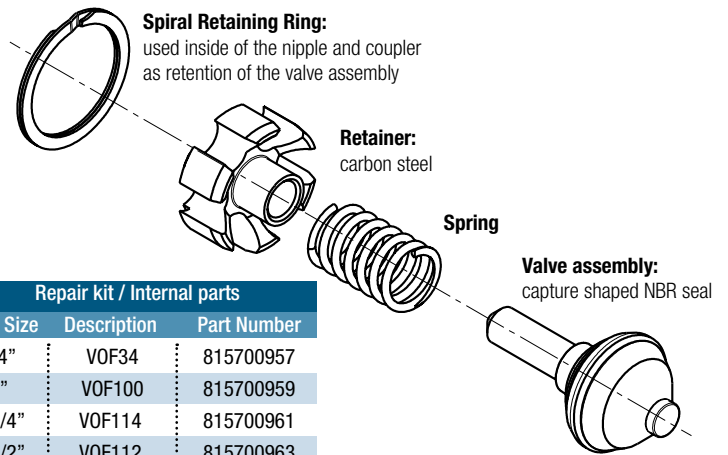

Repair kit / Internal parts		
Body Size	Description	Part Number
3/4"	VOF34	815700957
1"	VOF100	815700959
1-1/4"	VOF114	815700961
1-1/2"	VOF112	815700963
2"	VOF200	815700965

*same codes for coupler or nipple

PROTECTIVE CAPS FOR VOF SERIES

Protective caps are always recommended to protect the couplings from damage, dirt inclusion, and will increase the product life.

This is particularly important in Oil&Gas and mobile applications where exposure to weather and aggregate materials are common.

The protective caps for VOF couplings are manufactured in aluminum (natural color).

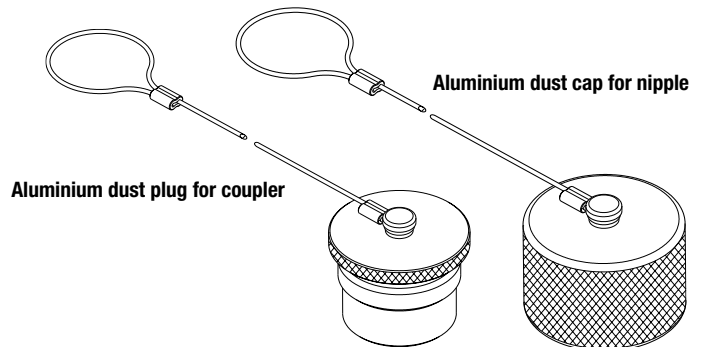

Body Size/Description	Protective Cap		Material/Color
	Plug for Coupler	Cap for Nipple	
3/4"	815405013	815405012	Aluminum/Natural
1"	815405011	815405010	Aluminum/Natural
1-1/4"	815405015	815405014	Aluminum/Natural
1-1/2"	815405017	815405016	Aluminum/Natural
2"	815405019	815405018	Aluminum/Natural

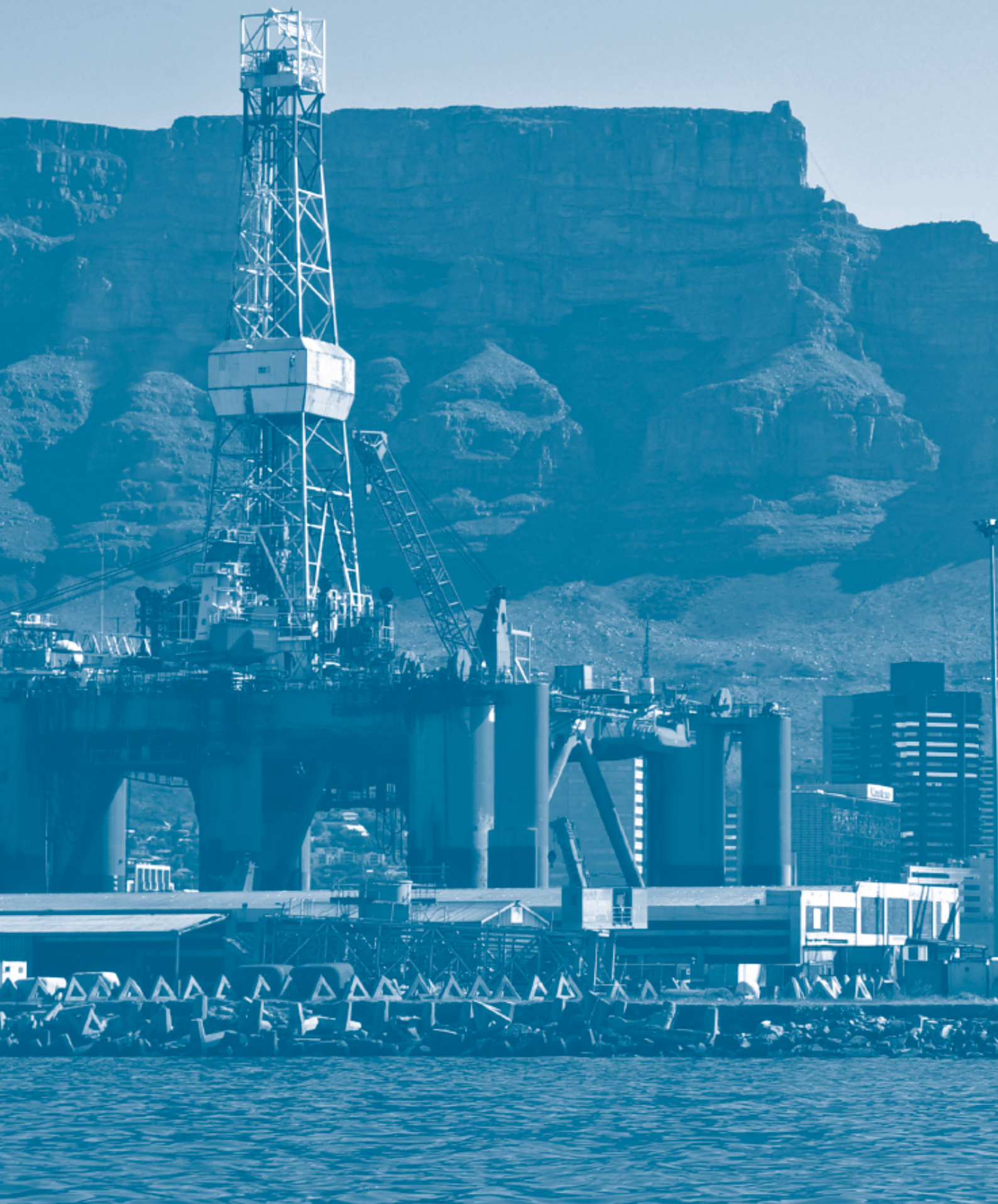

VOFX SERIES

INTERCHANGE > Similar Couplings (Oil & Gas)



BOP



TECHNICAL FEATURES AND OPTIONS

Interchange Similar Couplings (Oil & Gas)	Sealing description Nitrile NBR	Connection system Screw
Available sizes From 3/4" to 2"	Material Stainless steel (AISI 316L)	Available threads NPT - BSP
Operating pressure Up to 207 bar	Locking mechanism Screw to connect	Flow rate Up to 1100 l/min
Temperature (°C) -20° / +100°	Valving style Poppet	Connection under pressure Connection: one side Disconnection: not allowed

BENEFITS

- Connection under residual pressure is allowed in one side.
- Inspection hole to control if the coupling is completely connected.
- All dimensions of Stucchi VOFX series are certified with Lloyd Type Approval in accordance with API 16D at specific rating pressure of 207 bar/3000 PSI.
- New treatment on the threads to avoid premature wearing.
- Wrench flat on the bodies to facilitate the fitting assembly.
- The poppet valve with elastomer seal provides maximum sealing of the couplings when disconnected.
- Retainer in stainless steel material.
- Shape of internal parts is designed to reduce turbulence and pressure drop.
- High resistance to pressure impulses (500.000 connected).
- Compact design.
- Simple to use.

HOW TO USE

- Before to connect, clean the mating surface of the couplings and spread anti galling paste on the thread.
- To connect insert the nipple in the coupler, screw the sleeve until positive stop (surface contact of two moving parts), do not push together the couplings, screw only.
- The use of tools for the second part of the connection can be necessary if there is high residual pressure in the circuit.
- Check inspection holes to ensure that the coupling is fully connected (no free space allowed).
- To disconnect unscrew totally the sleeve from the nipple.

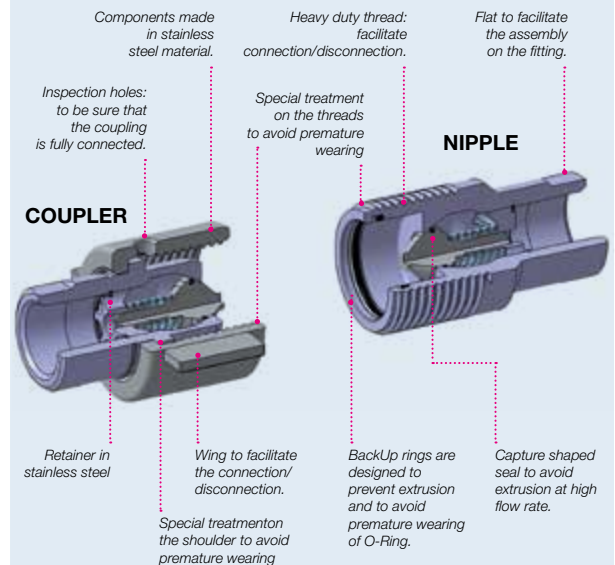
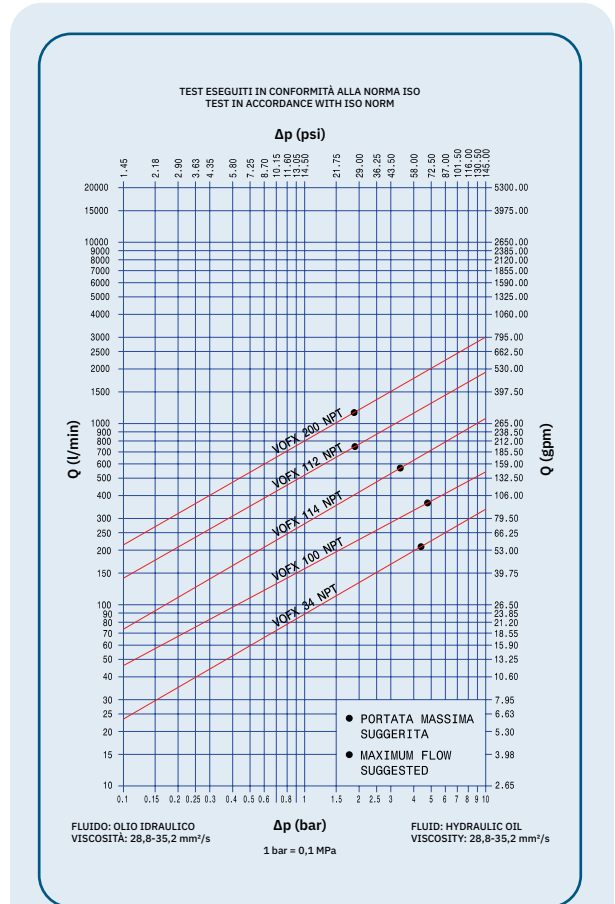

MAIN APPLICATIONS



POP PET SCREW

PERFORMANCES

Size		Series/Size	Max. flow suggested		Manual connect torque*		Manual disconnect torque*		Spillage**
Inch	mm		l/min	gpm	Nm	lbf ft	Nm	lbf ft	ml
3/4"	20	VOFX34	212	56,18	2,3	1,70	2,3	1,70	11,5
1"	25	VOFX100	378	100,17	2,5	1,84	2,5	1,84	21,2
1-1/4"	31,5	VOFX114	576	152,64	3	2,21	3	2,21	42,3
1-1/2"	40	VOFX112	758	200,87	15,1	11,14	15,2	11,21	82,6
2"	50	VOFX200	1100	291,50	10	7,38	10	7,38	192,0

Size	Series/Size	Max. operating pressure						Burst pressure					
		Coupled		Nipple		Coupler		Coupled		Nipple		Coupler	
Inch		MPa	psi	MPa	psi	MPa	psi	MPa	psi	MPa	psi	MPa	psi
3/4"	VOFX34	20,7	3000	20,7	3000	20,7	3000	82,8	12000	62,1	9000	62,1	9000
1"	VOFX100	20,7	3000	20,7	3000	20,7	3000	82,8	12000	62,1	9000	62,1	9000
1-1/4"	VOFX114	20,7	3000	20,7	3000	20,7	3000	82,8	12000	62,1	9000	62,1	9000
1-1/2"	VOFX112	20,7	3000	20,7	3000	20,7	3000	82,8	12000	62,1	9000	62,1	9000
2"	VOFX200	20,7	3000	20,7	3000	20,7	3000	82,8	12000	62,1	9000	41,4	6000

* Connect torque and disconnect torque without residual pressure. The torque to connect increase with increasing of internal residual pressure.

** Spillage is an indicative value of the fluid loss per couple-uncouple cycle without residual pressure.

All dimensions of Stucchi VOFX series are certified with Lloyd Type. Approval in accordance with API 16D at specific rating pressure of 207 bar/3000 PSI. For complete technical information please contact Stucchi Technical Support.

Different possible configurations:

SAE thread available upon request.

Material:

- Construction: Stainless steel AISI 316L
- Springs and elastic rings: AISI 302

Temperature range:

Standard seals NBR from -20 °C to +100 °C (from -4 °F to +212 °F). Please read carefully Instructions and warnings for proper selection of the products.

Tests performed:

The couplings coupled have been tested at max. operating pressure for 500.000 impulses in accordance with ISO norm. The couplings uncoupled have been tested for 100.000 impulses.

⚠ WARNING

A defect, a wrong choice or an improper use of products, can cause injury to persons, animals and objects.

Never connect or disconnect with dynamic pressure (e.g. pump on).

Do not couple-uncouple with flow in the circuit.

Do not couple-uncouple when the temperature inside of the circuit is higher than 80 °C (176 °F).

Do not use the coupling disconnected with high impulse pressure.

Connect under pressure products are suitable to be connected under residual (static) pressure.

Connection with residual pressure (pressure trapped in the circuit) allowed with other side coupling to drain.

Check the maximum allowable working pressure of the port in use.

Make sure that the medium used is compatible with seal and material as indicated for each series.

In case of doubt please contact Stucchi Technical Support.

The interchangeability is mentioned under the assumption that the manufacturer of the considered products has not changed any dimension.

It is mandatory to carefully read and closely follow the instructions before selecting or using any Stucchi products.

Always refer to the version uploaded in the Instructions and warning section of stucchigroup.com website for the latest release.

For specific, product-related, instructions, please contact Stucchi technical service.

OVERALL DIMENSIONS

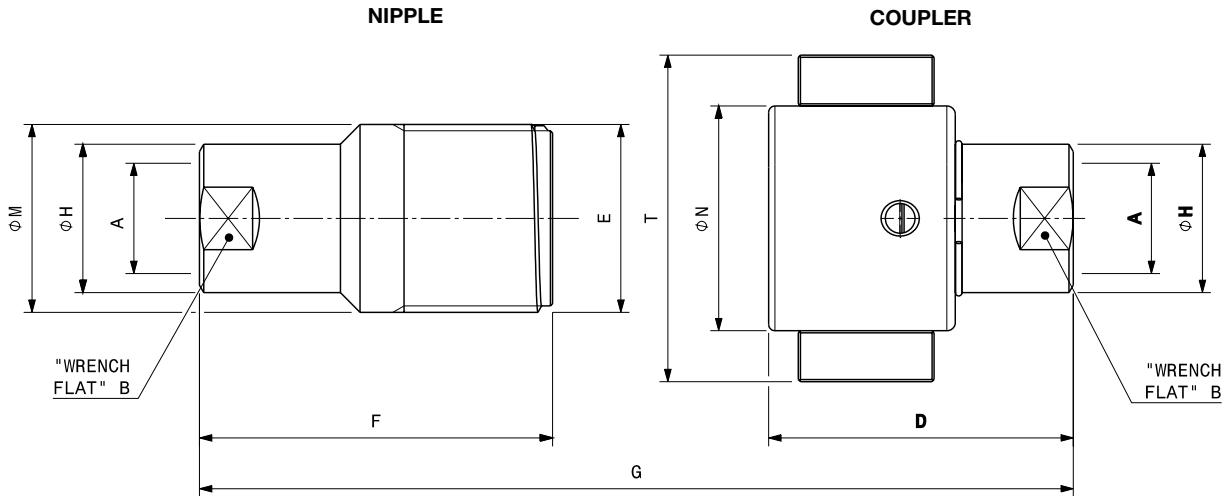

Port description: FEMALE THREAD NPT (ANSI B.1.20.1)

BODY SIZE	Descriptive Code	Item Code	PORT (A)	Thread	Overall Length		Length		Hex		Diameter						
					mm	inch	mm	inch	mm	inch	mm	inch					
3/4"	VOFX34 NPT Nipple	811201050	3/4"	E	1 3/4-8" special	G	123,6	4,87	F	83,2	3,28	B	31,8	1,25	H	35,0	1,38
	VOFX34 NPT Coupler	811201051							D	71,8	2,83						
1"	VOFX100 NPT Nipple	811201052	1"	E	2 1/4-6 Stub ACME	G	152,9	6,02	F	105,8	4,17	B	41,3	1,63	H	45,0	1,77
	VOFX100 NPT Coupler	811201053							D	87,3	3,44						
1-1/4"	VOFX114 NPT Nipple	811201054	1-1/4"	E	2 5/8-6 Stub ACME	G	197,9	7,79	F	136,7	5,38	B	50,8	2,00	H	54,5	2,15
	VOFX114 NPT Coupler	811201055							D	112,4	4,43						
1-1/2"	VOFX112 NPT Nipple	811201056	1-1/2"	E	3 1/4-4 Stub ACME	G	220,3	8,67	F	151,2	5,95	B	57,2	2,25	H	63,5	2,50
	VOFX112 NPT Coupler	811201057							D	126,9	5,00						
2"	VOFX200 NPT Nipple	811201058	2"	E	4-4 Stub ACME	G	255,2	10,05	F	179,0	7,05	B	76,2	3,00	H	82,6	3,25
	VOFX200 NPT Coupler	811201059							D	154,2	6,07						

BODY SIZE	Descriptive Code	Item Code		Diameter		Max overall dimension		Weight	
				mm	inch	mm	inch	Kg	Lbs
3/4"	VOFX34 NPT Nipple	811201050	M	44,3	1,74			0,48	1,05
	VOFX34 NPT Coupler	811201051	N	53,0	2,09	T	77,0	3,03	0,61
1"	VOFX100 NPT Nipple	811201052	M	57,2	2,25			1,19	2,62
	VOFX100 NPT Coupler	811201053	N	69,0	2,72	T	109,0	4,29	1,38
1-1/4"	VOFX114 NPT Nipple	811201054	M	66,7	2,62			1,95	4,30
	VOFX114 NPT Coupler	811201055	N	80,0	3,15	T	120,0	4,72	2,27
1-1/2"	VOFX112 NPT Nipple	811201056	M	82,6	3,25			3,22	7,11
	VOFX112 NPT Coupler	811201057	N	95,0	3,74	T	145,0	5,71	3,84
2"	VOFX200 NPT Nipple	811201058	M	101,6	4,00			6,04	13,32
	VOFX200 NPT Coupler	811201059	N	122,5	4,82	T	182,5	7,19	8,10

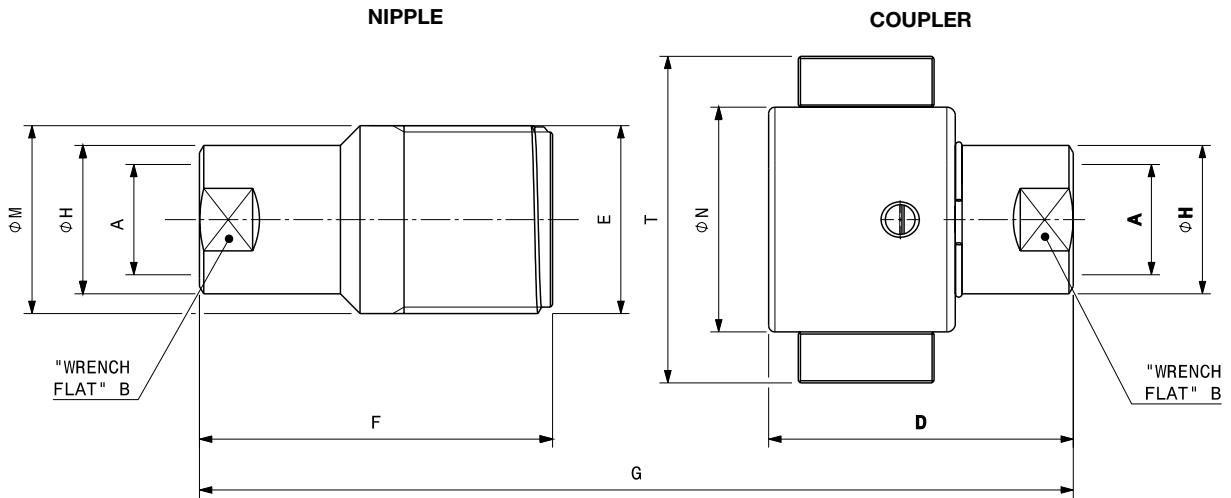

Port description: FEMALE THREAD BSPP (ISO 1179-1)

BODY SIZE	Descriptive Code	Item Code	PORT (A)		Thread	Overall Length	Length		Hex		Diameter						
			mm	inch			mm	inch	mm	inch	mm	inch					
3/4"	VOFX34 BSP	Nipple 811200050	3/4"	E	1 3/4-8* special	G	123,6	4,87	F	83,2	3,28	B	31,8	1,25	H	35,0	1,38
	VOFX34 BSP	Coupler 811200051							D	71,8	2,83						
1"	VOFX100 BSP	Nipple 811200052	1"	E	2 1/4-6 Stub ACME	G	152,9	6,02	F	105,8	4,17	B	41,3	1,63	H	45,0	1,77
	VOFX100 BSP	Coupler 811200053							D	87,3	3,44						
1-1/4"	VOFX114 BSP	Nipple 811200054	1-1/4"	E	2 5/8-6 Stub ACME	G	197,9	7,79	F	136,7	5,38	B	50,8	2,00	H	54,5	2,15
	VOFX114 BSP	Coupler 811200055							D	112,4	4,43						
1-1/2"	VOFX112 BSP	Nipple 811200056	1-1/2"	E	3 1/4-4 Stub ACME	G	220,3	8,67	F	151,2	5,95	B	57,2	2,25	H	63,5	2,50
	VOFX112 BSP	Coupler 811200057							D	126,9	5,00						
2"	VOFX200 BSP	Nipple 811200058	2"	E	4-4 Stub ACME	G	255,2	10,05	F	179,0	7,05	B	76,2	3,00	H	82,6	3,25
	VOFX200 BSP	Coupler 811200059							D	154,2	6,07						

BODY SIZE	Descriptive Code	Item Code	Diameter		Overall dimension		Weight		
			mm	inch	mm	inch	Kg	Lbs	
3/4"	VOFX34 BSP	Nipple 811200050	M	44,3	1,74			0,48	1,05
	VOFX34 BSP	Coupler 811200051	N	53,0	2,09	T	77,0	3,03	0,61
1"	VOFX100 BSP	Nipple 811200052	M	57,2	2,25			1,19	2,62
	VOFX100 BSP	Coupler 811200053	N	69,0	2,72	T	109,0	4,29	1,38
1-1/4"	VOFX114 BSP	Nipple 811200054	M	66,7	2,62			1,95	4,30
	VOFX114 BSP	Coupler 811200055	N	80,0	3,15	T	120,0	4,72	2,27
1-1/2"	VOFX112 BSP	Nipple 811200056	M	82,6	3,25			3,22	7,11
	VOFX112 BSP	Coupler 811200057	N	95,0	3,74	T	145,0	5,71	3,84
2"	VOFX200 BSP	Nipple 811200058	M	101,6	4,00			6,04	13,32
	VOFX200 BSP	Coupler 811200059	N	122,5	4,82	T	182,5	7,19	8,10



SPARE KIT SEAL FOR NIPPLE

Repair kit / OR+BK		
Body Size	Description	Part Number
3/4"	VOFX34	815700956
1"	VOFX100	815700958
1-1/4"	VOFX114	815700960
1-1/2"	VOFX112	815701122
2"	VOFX200	815700964

O-Ring in Nitrile
BackUp in Teflon®

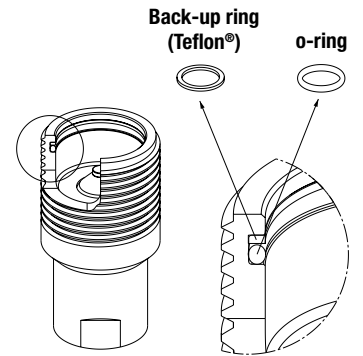

SPARE KIT INTERNAL PARTS

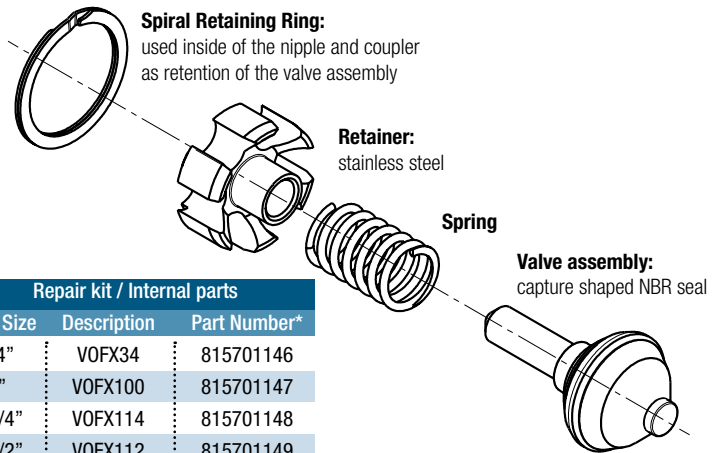

Repair kit / Internal parts		
Body Size	Description	Part Number*
3/4"	VOFX34	815701146
1"	VOFX100	815701147
1-1/4"	VOFX114	815701148
1-1/2"	VOFX112	815701149
2"	VOFX200	815701150

*same codes for coupler or nipple

PROTECTIVE CAPS FOR VOFX SERIES

Protective caps are always recommended to protect the couplings from damage, dirt inclusion, and will increase the product life. This is particularly important in Oil&Gas and mobile applications where exposure to weather and aggregate materials are common. The protective caps for VOFX couplings are manufactured in aluminum (natural color). Upon request also caps manufactured in stainless steel version.

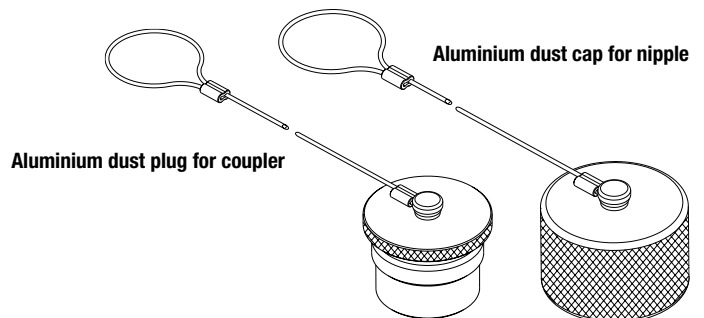

Body Size/Description :	Protective Cap		Material/Color
	Plug for Coupler	Cap for Nipple	
3/4"	815405013	815405012	Aluminum/Natural
1"	815405011	815405010	Aluminum/Natural
1-1/4"	815405015	815405014	Aluminum/Natural
1-1/2"	815405017	815405016	Aluminum/Natural
2"	815405019	815405018	Aluminum/Natural



VRSERIES

INTERCHANGE > Similar Couplings (type "Rohrleitung")



Stucchi®



TECHNICAL FEATURES AND OPTIONS

Interchange Similar Couplings (type "Rohrleitung")	Sealing description Nitrile NBR	Connection system Screw
Available sizes From 3/8" to 1-1/4"	Material/treatment Carbon steel /Cr3	Available threads METRIC
Operating pressure Up to 420 bar	Locking mechanism Screw to connect	Flow rate Up to 576 l/min
Temperature (°C) -20° / +100°	Valving style Flat face Non spill	Connection under pressure Connection: one side Disconnection: not allowed

BENEFITS

- Connection is allowed in one half of the coupling up to 10 MPa (4 MPa for size 1-1/4)
- Robustness and ease of construction.
- Special valves ensure a good seal of the coupling disconnected and minimize spillage of fluid.
- Shape of internal parts is designed to reduce turbulence and pressure drop.
- External sleeve protects the sealing surface of the male body
- Good resistance to pressure impulses.
- Compact design.
- Simple to use.

HOW TO USE

- Before to connect, clean the mating surface of the couplings to avoid dirt inclusion in the circuit.
- To connect insert the male coupling in the female coupling, screw the sleeve till the stop, do not push together the couplings, screw only.
- The use of tools for the second part of the connection can be necessary if there is high residual pressure in the circuit.
- To disconnect unscrew totally the sleeve from the female coupling.

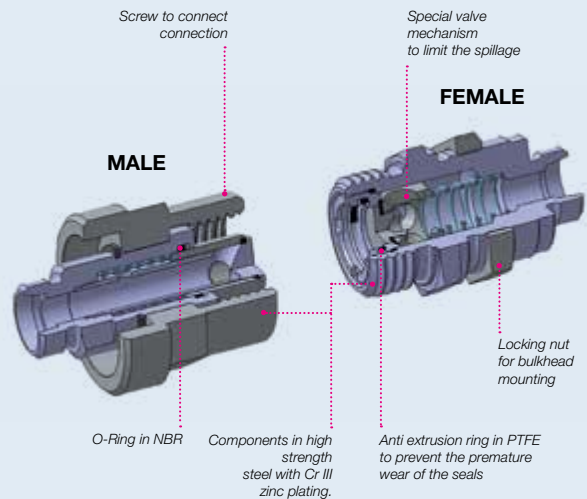
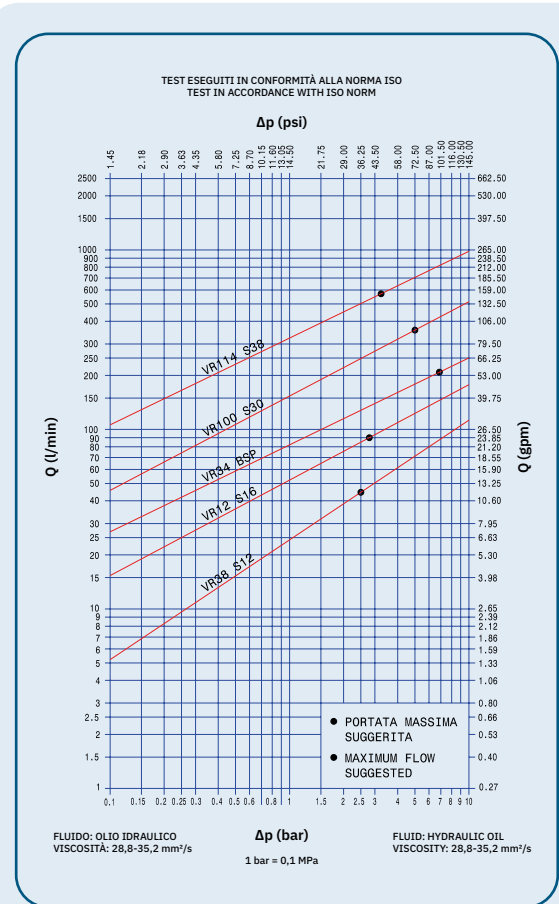

MAIN APPLICATIONS

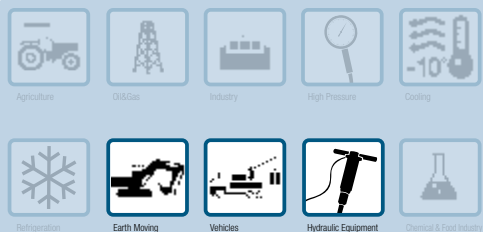

POPET SCREW

PERFORMANCES

Size		Series/Size	Max. flow suggested		Manual connect torque*		Manual disconnect torque*		Spillage**
Inch	mm		l/min	gpm	Nm	lbf ft	Nm	lbf ft	ml
3/8	10	VR38	46	12,19	2	1,47	1,8	1,33	0,01
1/2	12,5	VR12	90	23,85	1,3	0,96	0,7	0,52	0,02
3/4	20	VR34	212	56,2	2,2	1,62	1,7	1,25	0,4
1	25	VR100	378	100,21	4,3	3,17	2,5	1,84	1
1-1/4	31,5	VR114	576	152,7	6	4,42	4	2,95	1

Size	Series/Size	Max. operating pressure						Burst pressure					
		Coupled		Male		Female		Coupled		Male		Female	
Inch		MPa	psi	MPa	psi	MPa	psi	MPa	psi	MPa	psi	MPa	psi
3/8	VR38	40	5800	20	2900	40	5800	160	23200	70	10150	100	14500
1/2	VR12	30	4350	17	2465	30	4350	140	20300	70	10150	100	14500
3/4	VR34	35	5075	20	2900	35	5075	140	20300	80	11600	100	14500
1	VR100	30	4350	20	2900	30	4350	100	14500	80	11600	100	14500
1-1/4	VR114	42	6090	42	6090	42	6090	120	17400	90	13050	100	14500

* Connect torque and disconnect torque without residual pressure.
The torque will increase as internal residual pressure increases.

** Spillage is an indicative value of the fluid loss during disconnection (according to ISO norm test method).

Different possible configurations:

Different threads available upon request.

Temperature range:

Standard seals NBR (Nitrile): from -20 °C to +100 °C (from -4 °F to +212 °F).
Please read carefully Instructions and warnings for proper selection of the products.

Tests performed:

The couplings coupled have been tested at maximum operating pressure for 200.000 impulses according to ISO norm test method.



WARNING

A defect, a wrong choice or an improper use of products, can cause injury to persons, animals and objects.

Never connect or disconnect with dynamic pressure (e.g. pump on).

Do not couple-uncouple with flow in the circuit.

Do not couple-uncouple when the temperature inside of the circuit is higher than 80 °C (176 °F).

Do not use the coupling disconnected with high impulse pressure.

Connect under pressure products are suitable to be connected under residual (static) pressure.

Connection with residual pressure (pressure trapped in the circuit) allowed with other side coupling to drain.

Check the maximum allowable working pressure of the port in use.

Make sure that the medium used is compatible with seal and material as indicated for each series.

In case of doubt please contact Stucchi Technical Support.

The interchangeability is mentioned under the assumption that the manufacturer of the considered products has not changed any dimension.

It is mandatory to carefully read and closely follow the instructions before selecting or using any Stucchi products.

Always refer to the version uploaded in the Instructions and warning section of stucchigroup.com website for the latest release.

For specific, product-related, instructions, please contact Stucchi technical service.

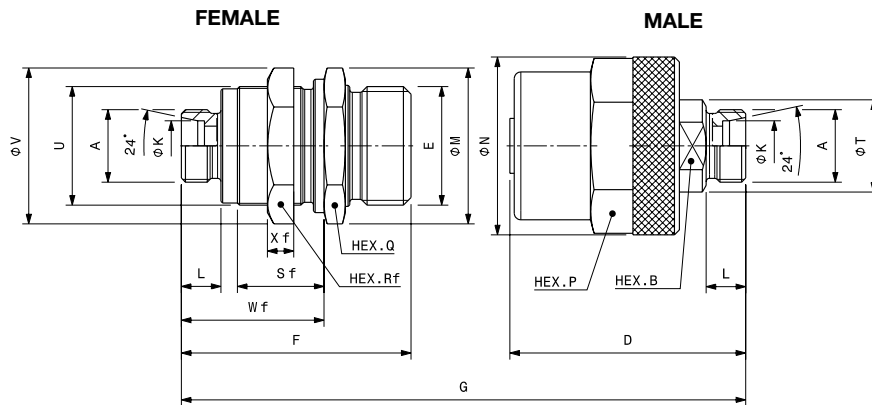
OVERALL DIMENSIONS

Port description: MALE THREAD METRIC L – 24° CONE (ISO 8434-1 & DIN 2353)

BODY SIZE	Descriptive Code	Item Code	BG	PORT (A)	U	E	Overall Length		Length		Hex		Hex		Diameter		Diameter							
							mm	inch	mm	inch	mm	inch	mm	inch	mm	inch	mm	inch	mm	inch				
3/8"	F VR38 L10	Female 809608002	2	M16X1.5	M30X1	32X3 SP*	G	107,5	4,23	F	60,0	2,36	Q	36,0	1,42	Rf	36,0	1,42	M	41,4	1,63	K	10,2	0,40
	M VR38 L10	Male 809608003								D	61,6	2,43	P	32,0	1,26	B	22,0	0,87	N	38,7	1,52			
3/8"	F VR38 L12	Female 809608004	2	M18X1.5	M30X1	32X3 SP*	G	107,5	4,23	F	60,0	2,36	Q	36,0	1,42	Rf	36,0	1,42	M	41,4	1,63	K	12,2	0,48
	M VR38 L12	Male 809608005								D	61,6	2,43	P	32,0	1,26	B	22,0	0,87	N	38,7	1,52			
3/8"	F VR38 L15	Female 809608006	2	M22X1.5	M30X1	32X3 SP*	G	109,5	4,31	F	61,0	2,40	Q	36,0	1,42	Rf	36,0	1,42	M	41,4	1,63	K	15,2	0,60
	M VR38 L15	Male 809608007								D	62,6	2,46	P	32,0	1,26	B	22,0	0,87	N	38,7	1,52			
1/2"	F VR12P L15	Female 809608026	3	M22X1.5	M36X1	36X3 SP*	G	124,6	4,91	F	70,5	2,78	Q	41,0	1,61	Rf	41,0	1,61	M	47,2	1,86	K	15,2	0,60
	M VR12 L15	Male 809608001								D	71,6	2,82	P	46,0	1,81	B	24,0	0,94	N	54,0	2,13			
3/4"	F VR34 L15	Female 809608016	4	M22X1.5	M45x1.5	48x3 SP*	G	150,1	5,91	F	90,1	3,55	Q	55,0	2,17	Rf	50,0	1,97	M	61,0	2,40	K	15,2	0,60
	M VR34 L15	Male 809608017								D	84,1	3,31	P	60,0	2,36	B	32,0	1,26	N	68,0	2,68			
3/4"	F VR34 L18	Female 809608018	4	M26x1.5	M45x1.5	48x3 SP*	G	150,1	5,91	F	90,1	3,55	Q	55,0	2,17	Rf	50,0	1,97	M	61,0	2,40	K	18,2	0,72
	M VR34 L18	Male 809608019								D	84,1	3,31	P	60,0	2,36	B	32,0	1,26	N	68,0	2,68			
1"	F VR100 L18	Female 809608008	6	M26X1.5	M54X1.5	54X4 SP*	G	174,5	6,87	F	96,2	3,79	Q	55,0	2,17	Rf	60,0	2,36	M	62,2	2,45	K	18,2	0,72
	M VR100 L18	Male 809608009								D	107,0	4,21	P	55,0	2,17	B	41,0	1,61	N	64,0	2,52			
1"	F VR100 L22	Female 809608010	6	M30X2	M54X1.5	54X4 SP*	G	178,5	7,03	F	98,2	3,87	Q	55,0	2,17	Rf	60,0	2,36	M	62,2	2,45	K	22,2	0,87
	M VR100 L22	Male 809608011								D	109,0	4,29	P	55,0	2,17	B	41,0	1,61	N	64,0	2,52			
1"	F VR100 L28	Female 809608012	6	M36X2	M54X1.5	54X4 SP*	G	178,5	7,03	F	98,2	3,87	Q	55,0	2,17	Rf	60,0	2,36	M	62,2	2,45	K	28,2	1,11
	M VR100 L28	Male 809608013								D	109,0	4,29	P	55,0	2,17	B	41,0	1,61	N	64,0	2,52			
1-1/4"	F VR114 L35	Female 809608014	8	M45x2	M80x2	79x4 SP*	G	213,5	8,39	F	123,0	4,84	Q	85,0	3,35	Rf	90,5 ^a	3,56 ^a	M	90,0	3,54	K	35,3	1,39
	M VR114 L35	Male 809608015								D	130,4	5,13	P	Δ	Δ	B	55,0	2,17	N	89,7	3,53			

BODY SIZE	Descriptive Code	Item Code		Diameter		Length		Length		Length		Weight				
				mm	inch	mm	inch	mm	inch	mm	inch	Kg	Lbs			
3/8"	F VR38 L10	Female 809608002	V	41,4	1,63	Wf	36,0	1,42	Sf	19,0	0,75	Xf	7,0	0,43	0,23	0,51
	M VR38 L10	Male 809608003	T	25,0	0,98							L	11,0	0,28	0,29	0,63
3/8"	F VR38 L12	Female 809608004	V	41,4	1,63	Wf	36,0	1,42	Sf	19,0	0,75	Xf	7,0	0,43	0,24	0,52
	M VR38 L12	Male 809608005	T	25,0	0,98							L	11,0	0,28	0,28	0,61
3/8"	F VR38 L15	Female 809608006	V	41,4	1,63	Wf	37,0	1,46	Sf	19,0	0,75	Xf	7,0	0,47	0,24	0,53
	M VR38 L15	Male 809608007	T	25,0	0,98							L	12,0	0,28	0,29	0,64
1/2"	F VR12 L15	Female 809608000	V	47,2	1,86	Wf	40,1	1,58	Sf	22,4	0,88	Xf	8,0	0,47	0,36	0,80
	M VR12 L15	Male 809608001	T	28,0	1,10							L	12,0	0,31	0,53	1,16
3/4"	F VR34 L15	Female 809608016	V	57,5	2,26	Wf	55,1	2,17	Sf	28,0	1,10	Xf	9,0	0,47	0,36	0,79
	M VR34 L15	Male 809608017	T	38,0	1,50							L	12,0	0,35	0,53	1,16
3/4"	F VR34 L18	Female 809608018	V	57,5	2,26	Wf	55,1	2,17	Sf	28,0	1,10	Xf	9,0	0,47	0,74	1,63
	M VR34 L18	Male 809608019	T	38,0	1,50							L	12,0	0,35	0,85	1,86
1"	F VR100 L18	Female 809608008	V	69,0	2,72	Wf	53,0	2,09	Sf	22,8	0,90	Xf	10,0	0,47	0,98	2,16
	M VR100 L18	Male 809608009	T	44,9	1,77							L	12,0	0,39	1,32	2,91
1"	F VR100 L22	Female 809608010	V	69,0	2,72	Wf	55,0	2,17	Sf	22,8	0,90	Xf	10,0	0,55	0,99	2,18
	M VR100 L22	Male 809608011	T	44,9	1,77							L	14,0	0,39	1,32	2,91
1"	F VR100 L28	Female 809608012	V	69,0	2,72	Wf	55,0	2,17	Sf	22,8	0,90	Xf	10,0	0,55	0,96	2,12
	M VR100 L28	Male 809608013	T	44,9	1,77							L	14,0	0,39	1,33	2,93
1-1/4"	F VR114 L35	Female 809608014	V	100,0	3,94	Wf	65,0	2,56	Sf	35,0	1,38	Xf	14,0	0,63	2,83	6,24
	M VR114 L35	Male 809608015	T	60,8	2,39							L	16,0	0,55	3,27	7,21

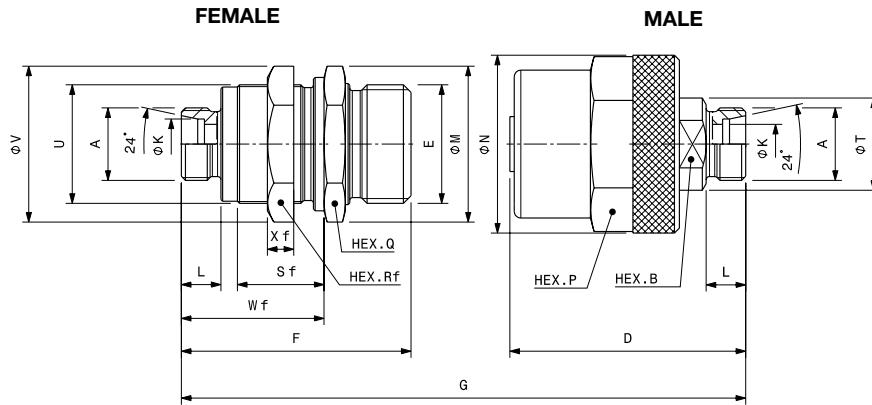
*SP = SPECIAL THREAD
 Δ to mount with a sickle spanner



Port description: MALE THREAD METRIC S – 24° CONE (ISO 8434-1 & DIN 2353)

BODY SIZE	Descriptive Code	Item Code	BG	PORT (A)	U	E	Overall Length		Length		Hex		Hex		Diameter		Diameter							
							mm	inch	mm	inch	mm	inch	mm	inch	mm	inch	mm	inch						
3/8"	F VR38 S10	Female 809609002	2	M18x1.5	M30X1	32X3 SP*	G	-	-	F	61,0	2,40	Q	36,0	1,42	Rf	36,0	1,42	M	41,4	1,63	K	10,2	0,40
	M VR38 S10	Male 809609003								D	-	-	P	-	-	B	-	-	N	-	-	N	-	-
3/8"	F VR38 S12	Female 809609004	2	M20x1.5	M30X1	32X3 SP*	G	109,5	4,31	F	61,0	2,40	Q	36,0	1,42	Rf	36,0	1,42	M	41,4	1,63	K	12,2	0,48
	M VR38 S12	Male 809609005								D	62,6	2,46	P	32,0	1,26	B	22,0	0,87	N	38,7	1,52	N	38,7	1,52
3/8"	F VR38 S14	Female 809609006	2	M22x1.5	M30X1	32X3 SP*	G	113,5	4,47	F	63,0	2,48	Q	36,0	1,42	Rf	36,0	1,42	M	41,4	1,63	K	14,2	0,56
	M VR38 S14	Male 809609007								D	64,6	2,54	P	32,0	1,26	B	22,0	0,87	N	38,7	1,52	N	38,7	1,52
3/8"	F VR38 S16	Female 809609016	2	M24x1.4	M30X1	32X3 SP*	G	113,5	4,47	F	63,0	2,48	Q	36,0	1,42	Rf	36,0	1,42	M	41,4	1,63	K	16,2	0,64
	M VR38 S16	Male 809609017								D	64,6	2,54	P	32,0	1,26	B	22,0	0,87	N	38,7	1,52	N	38,7	1,52
1/2"	F VR12P S16	Female 809609000	3	M24x1.5	M36X1	36X3 SP*	G	128,6	5,06	F	72,5	2,85	Q	41,0	1,61	Rf	41,0	1,61	M	47,2	1,86	K	16,2	0,64
	M VR12 S16	Male 809609001								D	73,6	2,90	P	46,0	1,81	B	24,0	0,94	N	54,0	2,13	N	54,0	2,13
1/2"	F VR12P S20	Female 809609030	3	M30x2	M36X1	36X3 SP*	G	157,8	6,21	F	74,5	2,93	Q	41,0	1,61	Rf	41,0	1,61	M	47,2	1,86	K	20,2	0,80
	M VR12 S20	Male 809609027**								D	100,8	3,97	P	46,0	1,81	B	32,0	1,26	N	54,0	2,13	N	54,0	2,13
3/4"	F VR34 S16	Female 809609020*	4	M24x1.5	M45x1.5	48X3 SP*	G	-	-	F	-	-	Q	-	-	Rf	-	-	M	-	-	K	16,2	0,64
	M VR34 S16	Male 809609021								D	86,1	3,39	P	60,0	2,36	B	32,0	1,26	N	68,0	2,68	N	68,0	2,68
3/4"	F VR34 S20	Female 809609018	4	M30X2	M45x1.5	48X3 SP*	G	158,1	6,22	F	94,1	3,70	Q	55,0	2,17	Rf	50,0	1,97	M	61,0	2,40	K	20,2	0,80
	M VR34 S20	Male 809609019								D	88,1	3,47	P	60,0	2,36	B	32,0	1,26	N	68,0	2,68	N	68,0	2,68
1"	F VR100 S20	Female 809609008	6	M30X2	M54x1.5	54X4 SP*	G	182,5	7,19	F	100,2	3,94	Q	55,0	2,17	Rf	60,0	2,36	M	62,2	2,45	K	20,2	0,80
	M VR100 S20	Male 809609009								D	111,0	4,37	P	55,0	2,17	B	41,0	1,61	N	64,0	2,52	N	64,0	2,52
1"	F VR100 S25	Female 809609010	6	M36X2	M54x1.5	54X4 SP*	G	186,5	7,34	F	102,2	4,02	Q	55,0	2,17	Rf	60,0	2,36	M	62,2	2,45	K	25,2	0,99
	M VR100 S25	Male 809609011								D	113,0	4,45	P	55,0	2,17	B	41,0	1,61	N	64,0	2,52	N	64,0	2,52
1"	F VR100 S30	Female 809609012	6	M42X2	M54x1.5	54X4 SP*	G	190,5	7,50	F	104,2	4,10	Q	55,0	2,17	Rf	60,0	2,36	M	62,2	2,45	K	30,2	1,19
	M VR100 S30	Male 809609013								D	115,0	4,53	P	55,0	2,17	B	41,0	1,61	N	64,0	2,52	N	64,0	2,52
1-1/4"	F VR114 S38	Female 809609014	8	M52X2	M80X2	79X4 SP*	G	225,15	8,86	F	129,0	5,08	Q	85,0	3,35	Rf	90,5*	3,56*	M	90,0	3,54	K	38,3	1,51
	M VR114 S38	Male 809609015								D	136,4	5,37	P	Δ	Δ	B	55,0	2,17	N	89,7	3,53	N	89,7	3,53

BODY SIZE	Descriptive Code	Item Code		Diameter		Length		Length		Length		Weight				
				mm	inch	mm	inch	mm	inch	mm	inch	Kg	Lbs			
3/8"	F VR38 S10	Female 809609002	V	41,4	1,63	Wf	37,0	1,46	Sf	19,0	0,75	Xf	7,0	0,28	0,24	0,11
	M VR38 S10	Male -	T	-	-	-	-	-	-	-	-	L	12,0	0,47	-	-
3/8"	F VR38 S12	Female 809609004	V	41,4	1,63	Wf	37,0	1,46	Sf	19,0	0,75	Xf	7,0	0,28	0,25	0,54
	M VR38 S12	Male 809609005	T	25,0	0,98	-	-	-	-	-	-	L	12,0	0,47	0,29	0,64
3/8"	F VR38 S14	Female 809609006	V	41,4	1,63	Wf	39,0	1,54	Sf	19,0	0,75	Xf	7,0	0,28	0,25	0,54
	M VR38 S14	Male 809609007	T	25,0	0,98	-	-	-	-	-	-	L	14,0	0,55	0,29	0,64
3/8"	F VR38 S16	Female 809609016	V	41,4	1,63	Wf	39,0	1,54	Sf	19,0	0,75	Xf	7,0	0,28	0,25	0,55
	M VR38 S16	Male 809609017	T	25,0	0,98	-	-	-	-	-	-	L	14,0	0,55	0,30	0,66
1/2"	F VR12 S16	Female 809609000	V	47,2	1,86	Wf	42,1	1,66	Sf	22,4	0,88	Xf	8,0	0,31	0,37	0,82
	M VR12 S16	Male 809609001	T	28,0	1,10	-	-	-	-	-	-	L	14,0	0,55	0,54	1,18
1/2"	F VR12 S20	Female 809609026	V	47,1	1,86	Wf	44,1	1,74	Sf	22,5	0,89	Xf	8,0	0,31	0,38	0,84
	M VR12 S20	Male 809609027	T	35,0	1,38	-	-	-	-	-	-	L	16,0	0,63	0,67	1,48
3/4"	F VR34 S16	Female -	V	-	-	Wf	-	-	Sf	-	-	Xf	-	-	-	-
	M VR34 S16	Male 809609021	T	38,0	1,50	-	-	-	-	-	-	L	14,0	0,55	0,85	1,87
3/4"	F VR34 S20	Female 809609018	V	57,5	2,26	Wf	59,1	2,33	Sf	28,0	1,10	Xf	9,0	0,35	0,37	0,82
	M VR34 S20	Male 809609019	T	38,0	1,50	-	-	-	-	-	-	L	16,0	0,63	0,87	1,91
1"	F VR100 S20	Female 809609008	V	69,0	2,72	Wf	57,0	2,24	Sf	22,8	0,90	Xf	10,0	0,39	1,01	2,23
	M VR100 S20	Male 809609009	T	44,9	1,77	-	-	-	-	-	-	L	16,0	0,63	1,34	2,95
1"	F VR100 S25	Female 809609010	V	69,0	2,72	Wf	59,0	2,32	Sf	22,8	0,90	Xf	10,0	0,39	1,01	2,23
	M VR100 S25	Male 809609011	T	44,9	1,77	-	-	-	-	-	-	L	18,0	0,71	1,36	3,00
1"	F VR100 S30	Female 809609012	V	69,0	2,72	Wf	61,0	2,40	Sf	22,8	0,90	Xf	10,0	0,39	1,02	2,24
	M VR100 S30	Male 809609013	T	44,9	1,77	-	-	-	-	-	-	L	20,0	0,79	1,38	3,03
1-1/4"	F VR114 S38	Female 809609014	V	100,0	3,94	Wf	71,0	2,80	Sf	35,0	1,38	Xf	14,0	0,55	2,89	6,37
	M VR114 S38	Male 809609015	T	60,8	2,39	-	-	-	-	-	-	L	22,0	0,87	3,31	7,30

SP* = SPECIAL THREAD
 Δ to mount with a sickle spanner
 ** = longer design with modular thread
 *Available upon request.



SPARE KIT SEAL FOR FEMALE

Repair kit / OR+BK		
Body Size	Description	Part Number
3/8"	F VR38	815700902
1/2"	F VR12	815700912
3/4"	F VR34	815700914
1"	F VR100	815700916
1-1/4"	F VR114	815700918

O-Ring in NBR
BackUp in Teflon®

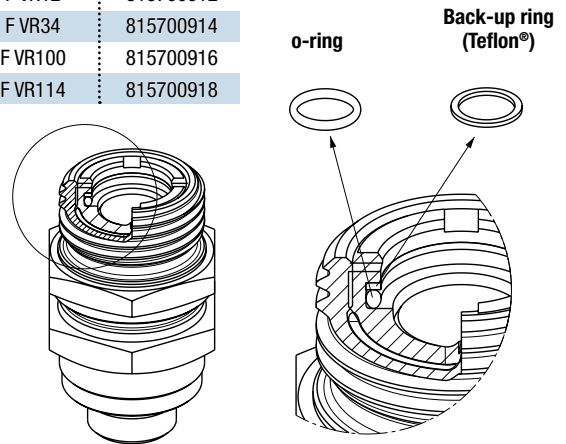

PROTECTIVE CAPS FOR VR SERIES

Protective caps are always recommended to protect the couplings from damage, dirt inclusion, and will increase the product life. This is particularly important in mobile applications where exposure to weather and aggregate materials are common.

Are available two models of protection caps for VR couplings:

- manufactured in plastic with connection lanyard (standard color: red, other colors available upon request)
- manufactured in aluminum screw caps with lanyard (standard color aluminum)

Cap for FEMALE coupling
Red Plastic

Plug for MALE coupling
Red Plastic

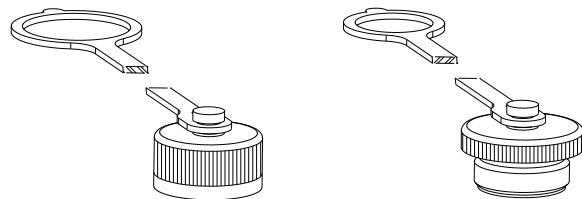

Body Size		Protective Cap		Material/Color
		Cap for Female	Plug for Male	
3/8"	VR38	814900012	814900013	Plastic/Red
1/2"	VR12	814900014	814900015	Plastic/Red

Cap for FEMALE coupling
Aluminum

Plug for MALE coupling
Aluminum

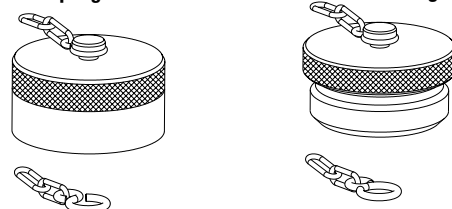

Body Size		Protective Cap		Material/Color
		Cap for Female	Plug for Male	
3/4"	VR34	814906016	814906017	Aluminum/Natural
1"	VR100	814906018	814906019	Aluminum/Natural
1-1/4"	VR114	814906020	814906021	Aluminum/Natural





BIR p. 149

Valving style: Poppet
 Interchange: ISO 7241 'A'
 Sealing description: Nitrile NBR
 Available sizes: From 1/4" to 2"
 Operating pressure: Up to 350 bar
 Flow rate: Up to 1000 l/min
 Material / Treatment:
 Carbon steel / Cr3
 Connection under pressure:
 Allowed (only PC version)



I/IP p. 157

Valving style: Poppet
 Interchange: ISO 7241 'A'
 Sealing description: Nitrile NBR
 Available sizes: From 1/4" to 1"
 Operating pressure: Up to 350 bar
 Flow rate: Up to 200 l/min
 Material / Treatment:
 Carbon steel / Cr3



IR p. 165

Valving style: Ball
 Interchange: With similar couplings
 Sealing description: Nitrile NBR
 Available sizes: From 1/4" to 1"
 Operating pressure: Up to 300 bar
 Flow rate: Up to 150 l/min
 Material / Treatment:
 Carbon steel / Cr3



IR-V p. 171

Valving style: Poppet
 Interchange:
 With similar couplings
 Sealing description: Nitrile NBR
 Available sizes: From 1/4" to 1"
 Operating pressure: Up to 300 bar
 Flow rate: Up to 200 l/min
 Material / Treatment:
 Carbon steel / Cr3



IRB p. 177

Valving style: Poppet
 Interchange: ISO 7241 'B'
 Sealing description: Nitrile NBR
 Available sizes: From 1/8" to 1"
 Operating pressure: Up to 350 bar
 Flow rate: Up to 200 l/min
 Material / Treatment:
 Carbon steel / Cr3



IRBO p. 183

Valving style: Poppet
 Interchange: ISO 7241 'B'
 Sealing description: FKM (Viton®)
 Available sizes: From 1/8" to 1"
 Operating pressure: Up to 200 bar
 Flow rate: Up to 200 l/min
 Material / Treatment: Brass



IRBX p. 189

Valving style: Poppet
 Interchange: ISO 7241 'B'
 Sealing description: FKM (Viton®)
 Available sizes: From 1/8" to 1"
 Operating pressure: Up to 250 bar
 Flow rate: Up to 200 l/min
 Material / Treatment:
 Stainless steel & brass



IRC p. 195

Valving style: Poppet
 Interchange: Nordic interface
 Sealing description: Nitrile NBR
 Available sizes: From 1/4" to 1"
 Operating pressure: Up to 450 bar
 Flow rate: Up to 378 l/min
 Material / Treatment:
 Carbon steel / Cr3
 Connection under pressure:
 Allowed (only PC version)



IRCX p. 201

Valving style: Poppet
 Interchange: Nordic interface
 Sealing description: FKM (Viton®)
 Available sizes: From 1/4" to 1"
 Operating pressure: Up to 300 bar
 Flow rate: Up to 378 l/min
 Material / Treatment:
 Stainless steel (AISI 316L)



IFR p. 207

Valving style: Flat face non-spill
 Interchange: ISO 5676
 Sealing description: Nitrile NBR
 Available sizes: 3/8"
 Operating pressure: Up to 150 bar
 Flow rate: Up to 46 l/min
 Material / Treatment:
 Carbon steel / Cr3















BIRSERIES

INTERCHANGE > ISO7241-1 "A"



TECHNICAL FEATURES AND OPTIONS

 Interchange ISO 7241 A	 Sealing description Nitrile NBR	 Connection system Single acting sleeve
 Available sizes From 1/4" to 2"	 Material/treatment Carbon steel /Cr3	 Available threads BSP - NPT - BSPT - SAE
 Operating pressure Up to 350 bar	 Locking mechanism Locking ball system	 Flow rate Up to 1000 l/min
 Temperature (°C) -20° / +100°	 Valving style Poppet	 Connection under pressure Only PC version Connection: one side Disconnection: not allowed

BENEFITS

- Connection under residual pressure is allowed in the male or in the female (PC version). Please notice that the counterpart side should be drained and should use a standard ISO A poppet half.
- The poppet valve with elastomer seal provides maximum sealing of the couplings once disconnected.
- Shape of internal parts is designed to reduce turbulence and pressure drop.
- Compact design.
- Simple to use.

HOW TO USE

- Before to connect, clean the mating surface of the couplings to avoid dirt inclusion in the circuit.
- To connect pull back the sleeve of the female coupling, align the female with the male coupling and push one into the other until both halves are fully connected and release the sleeve.
- To disconnect push back the sleeve of the female coupling, pull out the mating half.

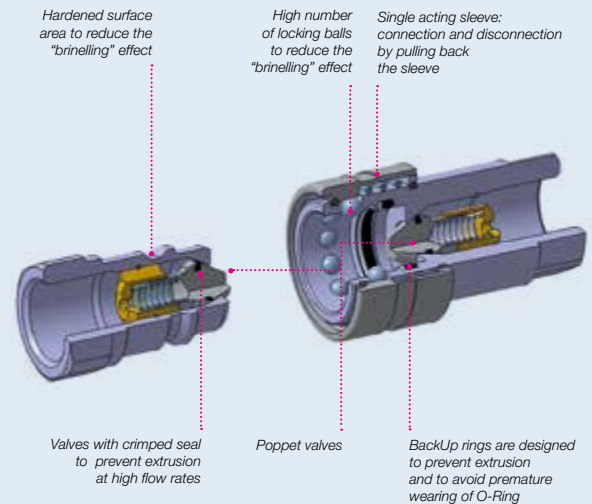
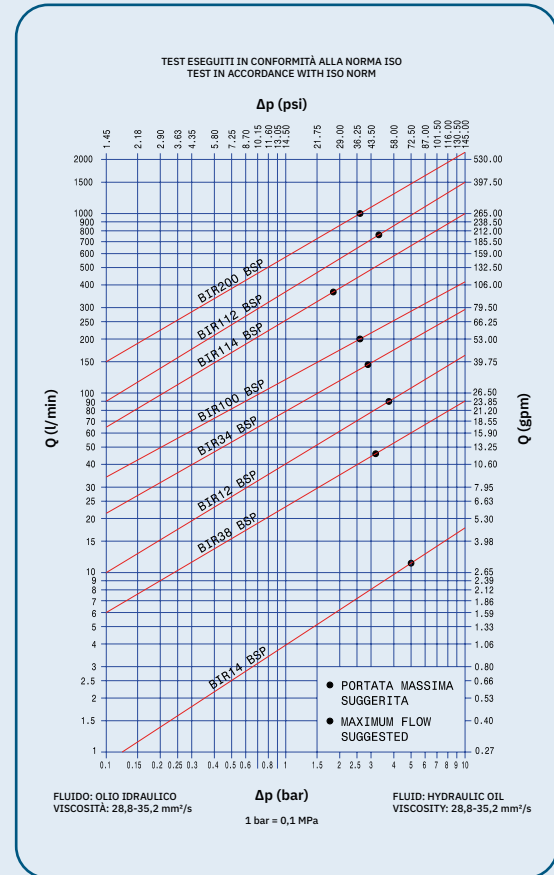

MAIN APPLICATIONS



PERFORMANCES

Size		Series/Size	Max. flow suggested		Connect force		Disconnect force		Spillage*
Inch	mm (ISO)		l/min	gpm	N	lbf	N	lbf	ml
1/4	6,3	BIR14	12	3,18	60	13,50	25	5,63	0,70
3/8	10,0	BIR38	46	12,19	90	20,25	30	6,75	1,20
1/2	12,5	BIR12	90	23,85	70	15,75	55	12,38	2,10
3/4	20,0	BIR34	148	39,22	140	31,50	55	12,38	5,20
1	25,0	BIR100	200	53,00	190	42,75	55	12,38	9,00
1-1/4	31,5	BIR114	378	100,17	230	51,75	55	12,38	27,00
1-1/2	40	BIR112	750	198,75	250	56,25	70	13,75	49,00
2	50	BIR200	1000	265,00	270	60,75	60	13,50	75,00

Size	Series/Size	Max. operating pressure						Burst pressure					
		Coupled		Male		Female		Coupled		Male		Female	
Inch		MPa	psi	MPa	psi	MPa	psi	MPa	psi	MPa	psi	MPa	psi
1/4	BIR14	35	5075	35	5075	35	5075	126	18270	126	18270	126	18270
3/8	BIR38	30	4350	30	4350	30	4350	100	14500	100	14500	100	14500
1/2	BIR12	25	3625	25	3625	25	3625	80	11600	80	11600	100	14500
3/4	BIR34	25	3625	25	3625	25	3625	100	14500	100	14500	100	14500
1	BIR100	23	3335	23	3335	23	3335	80	11600	80	11600	80	11600
1-1/4	BIR114	23	3335	23	3335	23	3335	80	11600	80	11600	80	11600
1-1/2	BIR112	18	2610	18	2610	18	2610	64	9280	64	9280	64	9280
2	BIR200	13	1885	13	1885	13	1885	40	5800	40	5800	40	5800

* Spillage is an indicative value of the fluid loss during disconnection (according to ISO norm test method).

Different possible configurations:

Thread BSPT and SAE available upon request.

PC version, special valve to connect under residual pressure possible either on male or on female side.

PL version, free flow (without valve) on both sides.

TIC version, shielded poppet to avoid flow-checking when used with other connect-under-pressure type couplers.

For complete technical information please contact Stucchi Technical Support.

Temperature range:

Standard seals in NBR (Nitrile): from -20 °C to +100 °C (from -4 °F to +212 °F).

Upon request seals in VITON®: from -15°C to +180°C (from +5 °F to +356 °F).

Please read carefully Instructions and warnings for proper selection of the products.

PC version

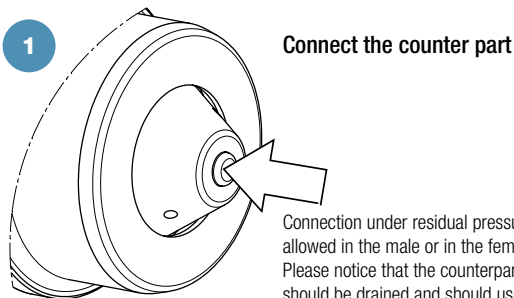

Connection under residual pressure is allowed in the male or in the female. Please notice that the counterpart side should be drained and should use a standard ISO A poppet half.

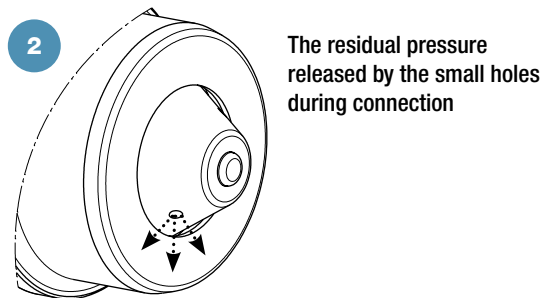

WARNING

A defect, a wrong choice or an improper use of products, can cause injury to persons, animals and objects.

Connect under pressure products (PC version) are suitable to be connected under residual (static) pressure.

Never connect or disconnect with dynamic pressure (e.g. pump on).

Do not couple-uncouple with flow and pressure in the circuit (except PC version).

Do not couple-uncouple when the temperature inside of the circuit is higher than 80 °C (176 °F).

Check the maximum allowable working pressure of the port in use.

Make sure that the medium used is compatible with seal and material as indicated for each series.

In case of doubt please contact Stucchi Technical Support.

The interchangeability is mentioned under the assumption that the manufacturer of the considered products has not changed any dimension.

It is mandatory to carefully read and closely follow the instructions before selecting or using any Stucchi products.

Always refer to the version uploaded in the Instructions and warning section of stuchigroup.com website for the latest release.

For specific, product-related, instructions, please contact Stucchi technical service.

OVERALL DIMENSIONS

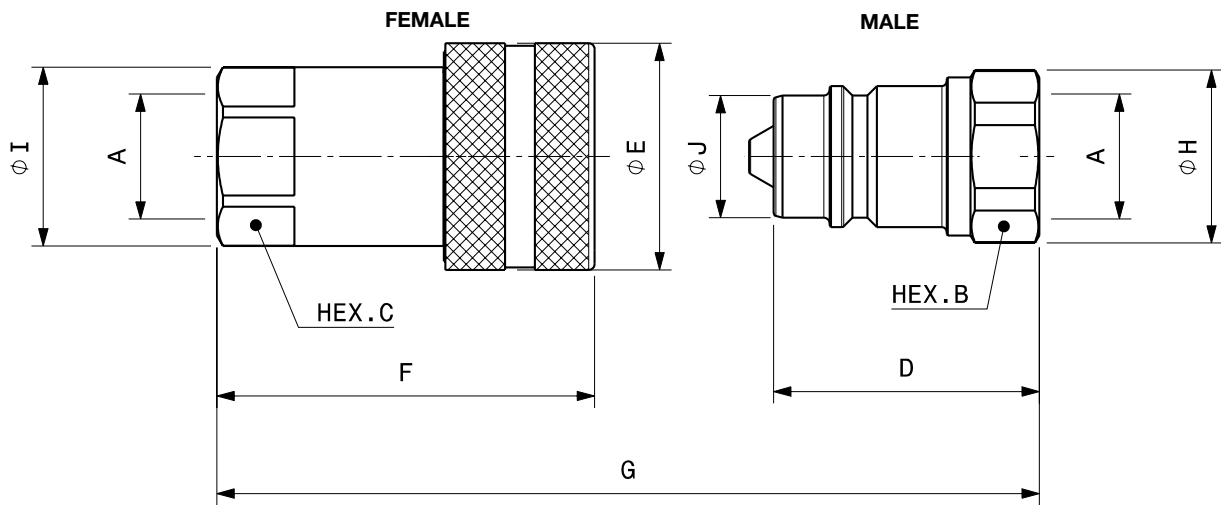

Port description: FEMALE THREAD BSPP (ISO 1179-1)

BODY SIZE	Descriptive Code	Item Code	ISO DN	PORT (A)	Overall Length		Length		Hex		Diameter		Diameter		Weight						
					mm	inch	mm	inch	mm	inch	mm	inch	mm	inch	Kg	Lbs					
1/4"	F BIR14 BSP	Female 800500000	6,3	1/4"	G	64,8	2,55	F	47,1	1,85	C	19,0	0,75	I	22,0	0,87	E	26,0	1,02	0,10	0,21
	M BIR14 BSP	Male 800500001						D	32,0	1,26	B	19,0	0,75	H	20,8	0,82	J	11,8	0,46	0,03	0,07
3/8"	F BIR38 BSP	Female 800500002	10	3/8"	G	76,8	3,02	F	56,1	2,21	C	22,0	0,87	I	24,0	0,94	E	31,0	1,22	0,14	0,32
	M BIR38 BSP	Male 800500003						D	38,0	1,50	B	22,0	0,87	H	24,0	0,94	J	17,3	0,68	0,05	0,11
1/2"	F BIR12 BSP	Female 800500004	12,5	1/2"	G	86,3	3,40	F	63,3	2,49	C	27,0	1,06	I	30,0	1,18	E	38,0	1,50	0,25	0,54
	M BIR12 BSP	Male 800500005						D	44,5	1,75	B	27,0	1,06	H	29,0	1,14	J	20,5	0,81	0,08	0,19
3/4"	F BIR34 BSP	Female 800500006	20	3/4"	G	111,1	4,37	F	82,2	3,24	C	38,0	1,50	I	44,0	1,73	E	48,0	1,89	0,49	1,09
	M BIR34 BSP	Male 800500007						D	55,0	2,17	B	36,0	1,42	H	38,5	1,52	J	29,1	1,15	0,21	0,45
1"	F BIR100 BSP	Female 800500008	25	1"	G	127,3	5,01	F	97,1	3,82	C	45,0	1,77	I	52,0	2,05	E	54,0	2,13	0,76	1,68
	M BIR100 BSP	Male 800500009						D	63,1	2,48	B	41,0	1,61	H	44,8	1,76	J	34,3	1,35	0,28	0,61
1-1/4"	F BIR114 BSP	Female 800500010	31,5	1-1/4"	G	151,2	5,95	F	117,2	4,61	C	50,0	1,97	I	55,5	2,19	E	65,0	2,56	1,25	2,76
	M BIR114 BSP	Male 800500011						D	75,0	2,95	B	55,0	2,17	H	60,0	2,36	J	45,0	1,77	0,59	1,31
1-1/2"	F BIR112 BSP	Female 800500012	40	1-1/2"	G	171,3	6,74	F	135,3	5,33	C	60,0	2,36	I	65,5	2,58	E	80,0	3,15	2,13	4,70
	M BIR112 BSP	Male 800500013						D	85,0	3,35	B	60,0	2,36	H	65,5	2,58	J	55,0	2,17	0,88	1,94
2"	F BIR200 BSP	Female 800500014	50	2"	G	201,2	7,92	F	160,2	6,31	C	75,0	2,95	I	83,7	3,30	E	100,0	3,94	4,13	9,10
	M BIR200 BSP	Male 800500015						D	100,0	3,94	B	75,0	2,95	H	82,5	3,25	J	65,0	2,56	1,44	3,17

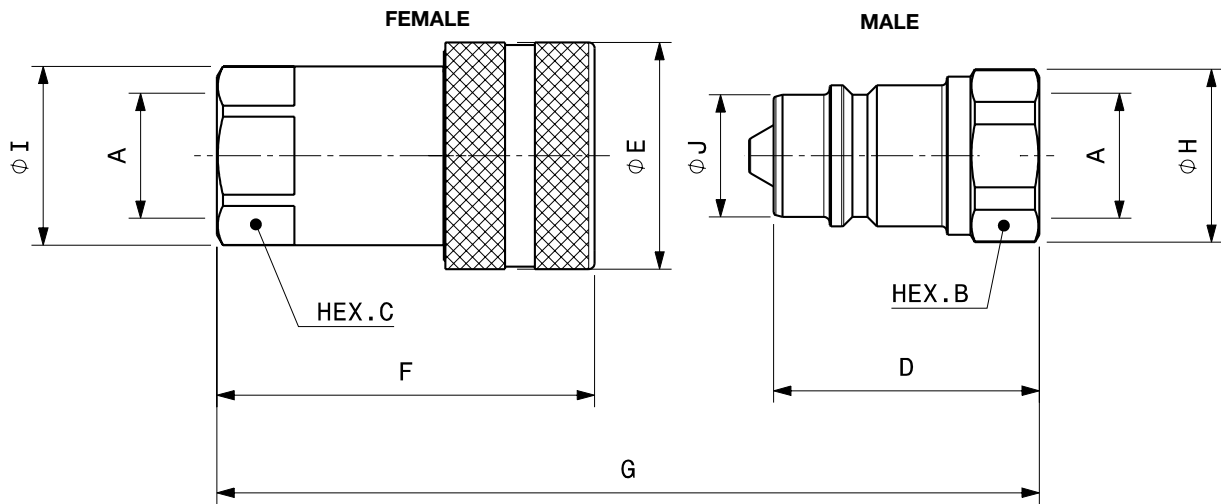

PC version poppet sealing system connectable under pressure

BODY SIZE	Descriptive Code	Item Code	ISO DN	PORT (A)	Overall Length		Length		Hex		Diameter		Diameter		Weight						
					mm	inch	mm	inch	mm	inch	mm	inch	mm	inch	Kg	Lbs					
1/2"	F BIR12PC BSP	Female 805600002	12,5	1/2"	G	86,3	3,40	F	63,3	2,49	C	27,0	1,06	I	30,0	1,18	E	38,0	1,50	0,25	0,54
	M BIR12PC BSP	Male 805600003						D	44,5	1,75	B	27,0	1,06	H	29,0	1,14	J	20,5	0,81	0,08	0,19

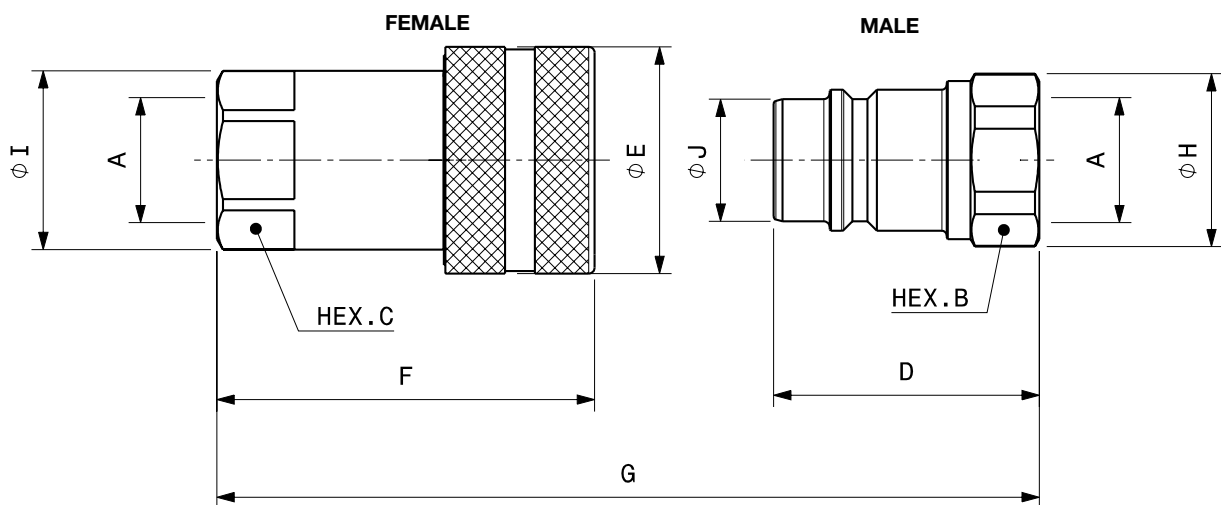

Port description: FEMALE THREAD BSPP (ISO 1179-1)

PL version full flow (without valve)

BODY SIZE	Descriptive Code	Item Code	ISO DN	PORT (A)	Overall Length		Length		Hex		Diameter		Diameter		Weight						
					mm	inch	mm	inch	mm	inch	mm	inch	mm	inch	Kg	Lbs					
1/4"	F BIR14PL BSP	Female 800500018	6,3	1/4"	G	64,8	2,55	F	47,1	1,85	C	19,0	0,75	I	22,0	0,87	E	26,0	1,02	0,10	0,21
	M BIR14PL BSP	Male 800500019						D	32,0	1,26	B	19,0	0,75	H	20,8	0,82	J	11,8	0,46	0,03	0,07
3/8"	F BIR38PL BSP	Female 800500022	10	3/8"	G	76,8	3,02	F	56,1	2,21	C	22,0	0,87	I	24,0	0,94	E	31,0	1,22	0,14	0,32
	M BIR38PL BSP	Male 800500023						D	38,0	1,50	B	22,0	0,87	H	24,0	0,94	J	17,3	0,68	0,05	0,11
1/2"	F BIR12PL BSP	Female 800500020	12,5	1/2"	G	86,3	3,40	F	63,3	2,49	C	27,0	1,06	I	30,0	1,18	E	38,0	1,50	0,25	0,54
	M BIR12PL BSP	Male 800500021						D	44,5	1,75	B	27,0	1,06	H	29,0	1,14	J	20,5	0,81	0,08	0,19
3/4"	F BIR34PL BSP	Female 800500016	20	3/4"	G	111,1	4,37	F	82,2	3,24	C	38,0	1,50	I	44,0	1,73	E	48,0	1,89	0,49	1,09
	M BIR34 PL BSP	Male 800500017						D	55,0	2,17	B	36,0	1,42	H	38,5	1,52	J	29,1	1,15	0,21	0,45
1"	F BIR100PL BSP	Female 800500024	25	1"	G	127,3	5,01	F	97,1	3,82	C	45,0	1,77	I	52,0	2,05	E	54,0	2,13	0,76	1,68
	M BIR100PL BSP	Male 800500025						D	63,1	2,48	B	41,0	1,61	H	44,8	1,76	J	34,3	1,35	0,28	0,61

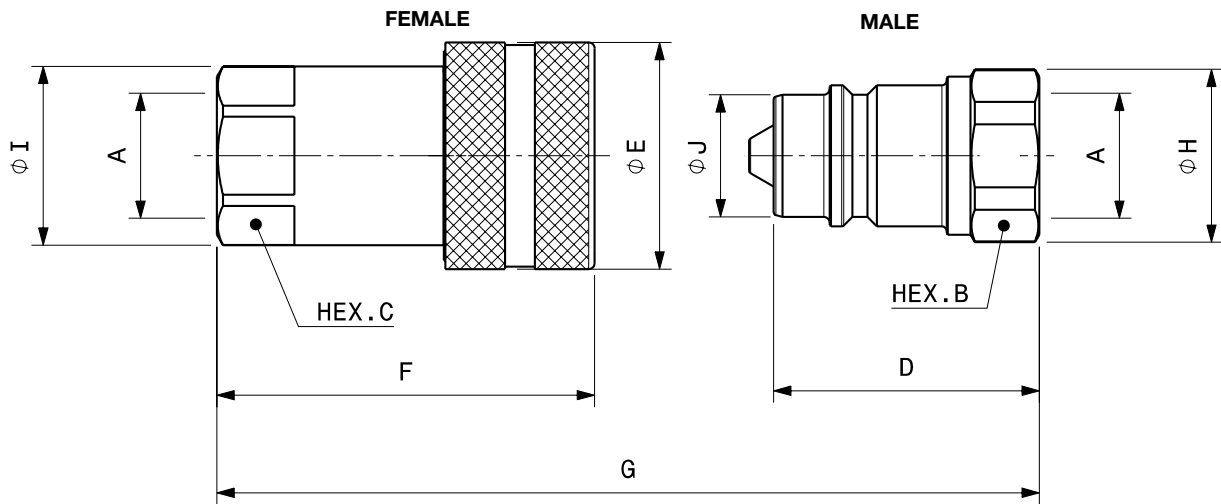

Port description: FEMALE THREAD NPT (ANSI B.1.20.1)

BODY SIZE	Descriptive Code	Item Code	ISO DN	PORT (A)	Overall Length		Length		Hex		Diameter		Diameter		Weight						
					mm	inch	mm	inch	mm	inch	mm	inch	mm	inch	Kg	Lbs					
1/4"	F BIR14 NPT	Female 800501000	6,3	1/4"	G	64,8	2,55	F	47,1	1,85	C	19,0	0,75	I	22,0	0,87	E	26,0	1,02	0,09	0,21
	M BIR14 NPT	Male 800501001						D	32,0	1,26	B	19,0	0,75	H	20,8	0,82	J	11,8	0,46	0,03	0,07
3/8"	F BIR38 NPT	Female 800501002	10	3/8"	G	76,8	3,02	F	56,1	2,21	C	22,0	0,87	I	24,0	0,94	E	31,0	1,22	0,15	0,32
	M BIR38 NPT	Male 800501003						D	38,0	1,50	B	22,0	0,87	H	24,0	0,94	J	17,3	0,68	0,05	0,12
1/2"	F BIR12 NPT	Female 800501004	12,5	1/2"	G	86,3	3,40	F	63,3	2,49	C	27,0	1,06	I	30,0	1,18	E	38,0	1,50	0,25	0,54
	M BIR12 NPT	Male 800501005						D	44,5	1,75	B	27,0	1,06	H	29,0	1,14	J	20,5	0,81	0,08	0,19
3/4"	F BIR34 NPT	Female 800501006	20	3/4"	G	111,1	4,37	F	82,2	3,24	C	38,0	1,50	I	44,0	1,73	E	48,0	1,89	0,50	1,11
	M BIR34 NPT	Male 800501007						D	55,0	2,17	B	36,0	1,42	H	38,5	1,52	J	29,1	1,15	0,21	0,46
1"	F BIR100 NPT	Female 800501008	25	1"	G	127,3	5,01	F	97,1	3,82	C	45,0	1,77	I	52,0	2,05	E	54,0	2,13	0,77	1,70
	M BIR100 NPT	Male 800501009						D	63,1	2,48	B	41,0	1,61	H	44,8	1,76	J	34,3	1,35	0,28	0,63
1-1/4"	F BIR114 NPT	Female 800501010	31,5	1-1/4"	G	151,2	5,95	F	117,2	4,61	C	50,0	1,97	I	55,5	2,19	E	65,0	2,56	1,24	2,74
	M BIR114 NPT	Male 800501011						D	75,0	2,95	B	55,0	2,17	H	60,0	2,36	J	45,0	1,77	0,62	1,36
1-1/2"	F BIR112 NPT	Female 800501012	40	1-1/2"	G	171,3	6,74	F	135,3	5,33	C	60,0	2,36	I	65,5	2,58	E	80,0	3,15	2,13	4,70
	M BIR112 NPT	Male 800501013						D	85,0	3,35	B	60,0	2,36	H	65,5	2,58	J	55,0	2,17	0,88	1,94
2"	F BIR200 NPT	Female 800501014	50	2"	G	201,2	7,92	F	160,2	6,31	C	75,0	2,95	I	83,7	3,30	E	100,0	3,94	4,13	9,10
	M BIR200 NPT	Male 800501015						D	100,0	3,94	B	75,0	2,95	H	82,5	3,25	J	65,0	2,56	1,44	3,17

PC version poppet sealing system connectable under pressure

BODY SIZE	Descriptive Code	Item Code	ISO DN	PORT (A)	Overall Length		Length		Hex		Diameter		Diameter		Weight						
					mm	inch	mm	inch	mm	inch	mm	inch	mm	inch	Kg	Lbs					
1/2"	F BIR12PC NPT	Female 805601000	12,5	1/2"	G	86,3	3,40	F	63,3	2,49	C	27,0	1,06	I	30,0	1,18	E	38,0	1,50	0,25	0,54
	M BIR12PC NPT	Male 805601001						D	44,5	1,75	B	27,0	1,06	H	29,0	1,14	J	20,5	0,81	0,08	0,19
1"	F BIR100PC NPT	Female 805601004	25	1"	G	127,3	5,01	F	97,1	3,82	C	45,0	1,77	I	52,0	2,05	E	54,0	2,13	0,81	1,79
	M BIR100PC NPT	Male 805601005						D	63,1	2,48	B	41,0	1,61	H	44,8	1,76	J	34,3	1,35	0,30	0,66

TIC version Shielded poppet to eliminate flow-checking when used with connect-under-pressure competitor couplers

BODY SIZE	Descriptive Code	Item Code	ISO DN	PORT (A)	Overall Length		Length		Hex		Diameter		Diameter		Weight						
					mm	inch	mm	inch	mm	inch	mm	inch	mm	inch	Kg	Lbs					
1/2"	M BIR12TIC NPT	Male 800501017	12,5	1/2"	G	86,3	3,40	D	47,0	1,85	B	27,0	1,06	H	30,0	1,18	J	20,5	0,81	0,08	0,19



SPARE KIT SEAL FOR FEMALE

Repair kit / OR (+BK)		
Body Size	Description	Part Number
1/4"	F BIR14	815700170
3/8"	F BIR38	815700172
1/2"	F BIR12	815700174
3/4"	F BIR34	815700176
1"	F BIR100	815700178
1-1/4"	F BIR114	815700180
1-1/2"	F BIR112	815700182
2"	F BIR200	815700184

O-Ring in Nitrile
BackUp in Teflon®

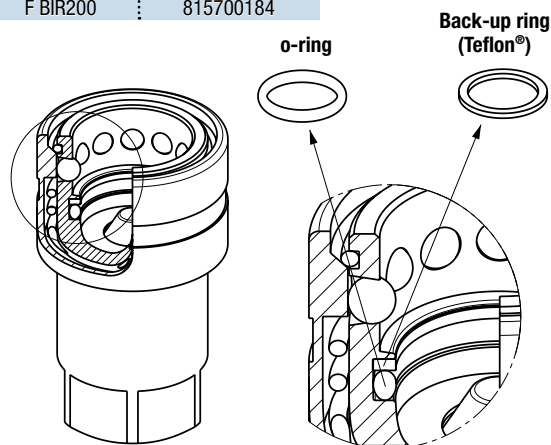

PARKING STATION FOR MALE

Parking station only (male coupling not included)		
Body Size	Description	Part Number
1/2"	PARK STATION FOR MALE BIR12	815515003

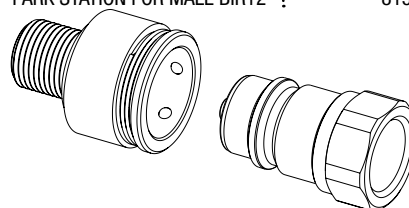

PROTECTIVE CAPS FOR BIR SERIES

Protective caps are always recommended to protect the couplings from damage, dirt inclusion, and will increase the product life. This is particularly important in agriculture applications where exposure to weather and aggregate materials are common. The protective caps for BIR series are manufactured in with connection lanyard (standard color red, other colors available upon request).

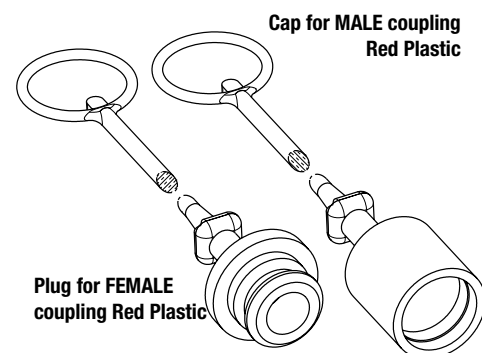

Body Size/Description		Protective Cap		Material/Color
		Plug for Female	Cap for Male	
1/4"	BIR14	815000012	815000013	Plastic/Red
3/8"	BIR38	815000014	815000015	Plastic/Red
1/2"	BIR12	815000004	815000005	Plastic/Red
3/4"	BIR34	815000016	815000017	Plastic/Red
1"	BIR100	815000018	815000019	Plastic/Red



IP SERIES

INTERCHANGE > ISO 7241 A



Stucchi®



TECHNICAL FEATURES AND OPTIONS

Interchange ISO 7241 A	Sealing description Nitrile NBR	Connection system Push - pull
Available sizes From 1/4" to 1"	Material/treatment Carbon steel /Cr3	Available threads BSP - NPT - METRIC
Operating pressure Up to 350 bar	Locking mechanism Locking Ball System	Flow rate Up to 200 l/min
Temperature (°C) -20° / +100°	Valving style Poppet	Connection under pressure Connection: not allowed Disconnection: not allowed

BENEFITS

- Breakaway function to avoid damages of the hydraulic connections in case of strong axial force during unintended disconnection.
- The poppet valve with elastomer seal provides maximum sealing of the couplings when disconnected.
- Shape of internal parts is designed to reduce turbulence and pressure drop.
- The modular design allows for broad range of port configurations.
- Compact design.
- Simple to use.

HOW TO USE

- For the breakaway function, the female coupling must be mounted in a panel, locking the sleeve using seeger/ snap rings.
- Provide the IP female with a flexible hose, in order to permit the movements of the internal body during connection and disconnection of the couplings.
- Before to connect, clean the mating surface of the couplings to avoid dirt inclusion in the circuit.
- To connect push the male coupling into the female coupling.
- To disconnect pull back the male coupling.

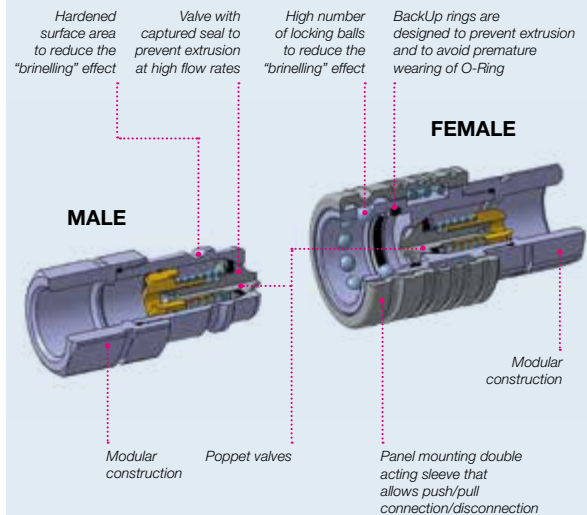
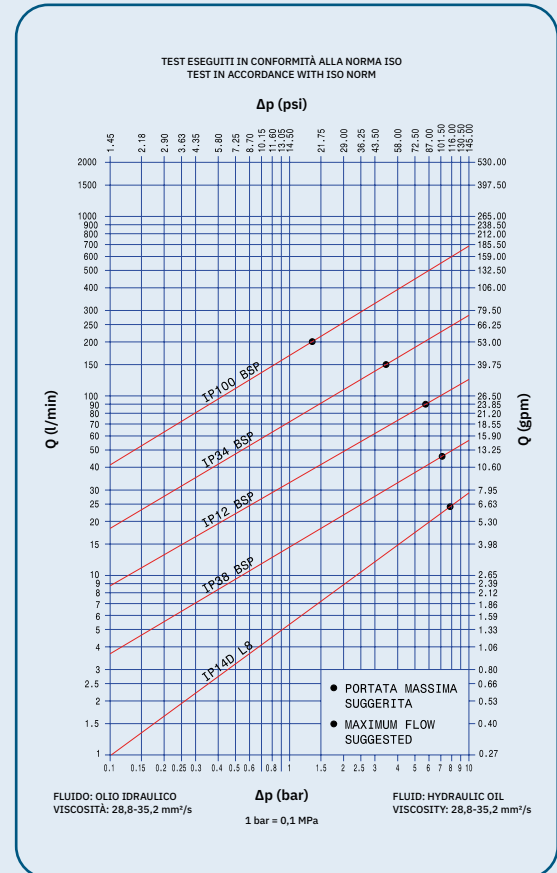

MAIN APPLICATIONS





PERFORMANCES

Size		Series/Size	Max. flow suggested		Connect force		Disconnect force		Spillage*
Inch	mm (ISO)		l/min	gpm	N	lbf	N	lbf	ml
1/4	6,3	F IP14D-M I14D **	24	6,36	27	6,08	17	3,83	0,30
3/8	10,0	F IP38-M I38	46	12,19	75	16,88	30	6,75	1,20
1/2	12,5	F IP12-M I12GS	90	23,85	90	20,25	80	18,00	1,80
3/4	20,0	F IP34-M I34	148	39,22	130	29,25	70	15,75	5,20
1	25,0	F IP100-M I100	200	53,00	300	67,50	70	15,75	13,00

Size	Series/Size	Max. operating pressure						Burst pressure					
		Coupled		Male		Female		Coupled		Male		Female	
Inch		MPa	psi	MPa	psi	MPa	psi	MPa	psi	MPa	psi	MPa	psi
1/4	F IP14D-M I14D **	35	5075	35	5075	35	5075	110	15950	126	18270	126	18270
3/8	F IP38-M I38	30	4350	30	4350	30	4350	100	14500	100	14500	100	14500
1/2	F IP12-M I12GS	25	3625	25	3625	25	3625	90	13050	100	14500	100	14500
3/4	F IP34-M I34	25	3625	25	3625	25	3625	90	13050	100	14500	100	14500
1	F IP100-M I100	25	3625	25	3625	25	3625	80	11600	100	14500	100	14500

* Spillage is an indicative value of the fluid loss during disconnection (according to ISO norm test method).

** I-IP 14 type "D" couplings are not ISO7241-1/A interchangeable.

Different possible configurations:

Different threads available upon request.

Temperature range:

Seals in NBR (Nitrile): from -20 °C to +100 °C (from -4 °F to +212 °F).

Please read carefully Instructions and warnings for proper selection of the products.

Tests:

The couplings have been tested at max. operating pressure for 200.000 impulses according to ISO norm test method.

⚠ WARNING

A defect, a wrong choice or an improper use of products, can cause injury to persons, animals and objects.

Never connect or disconnect with dynamic pressure (e.g. pump on).

Do not couple-uncouple with flow and/or pressure in the circuit.

Do not couple-uncouple when the temperature inside of the circuit is higher than 80 °C (176 °F).

Check the maximum allowable working pressure of the port in use.

Make sure that the medium used is compatible with seal and material as indicated for each series.

In case of doubt please contact Stucchi Technical Support.

The interchangeability is mentioned under the assumption that the manufacturer of the considered products has not changed any dimension.

It is mandatory to carefully read and closely follow the instructions before selecting or using any Stucchi products.

Always refer to the version uploaded in the Instructions and warning section of stucchigroup.com website for the latest release.

For specific, product-related, instructions, please contact Stucchi technical service.

OVERALL DIMENSIONS

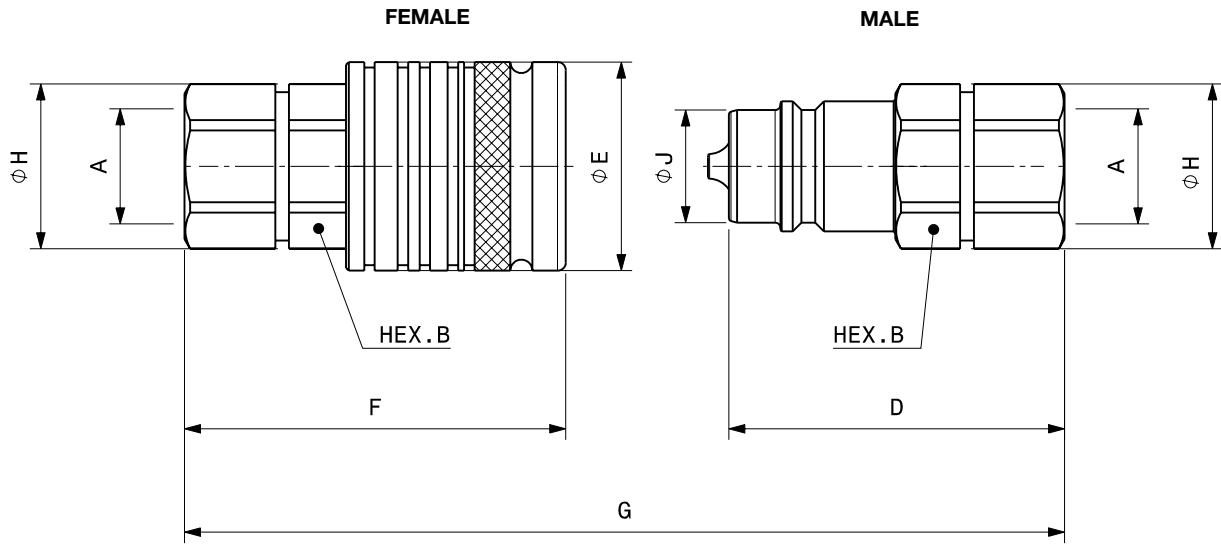

Port description: FEMALE THREAD BSP (ISO 1179-1)

BODY SIZE	Descriptive Code	Item Code	ISO DN	BG	PORT (A)	Overall Length	Length		Hex		Overall Diameter		Body Diameter		Weight							
							mm	inch	mm	inch	mm	inch	mm	inch	mm	inch	Kg	Lbs				
3/8"	F IP38 1/4 BSP	Female 809400008	10	2	1/4"	G	64,8	2,55	F	67,5	2,66	B	22,0	0,87	H	24,0	0,94	E	32,0	1,26	0,22	0,49
	M I38 1/4 BSP	Male 809400009							D	49,3	1,94	J	17,3	0,68	0,09	0,20						
3/8"	F IP38 3/8 BSP	Female 809400010	10	2	3/8"	G	76,8	3,02	F	70,5	2,78	B	22,0	0,87	H	24,0	0,94	E	32,0	1,26	0,22	0,49
	M I38 3/8 BSP	Male 809400011							D	52,3	2,06	J	17,3	0,68	0,09	0,20						
1/2"	F IP12 3/8 BSP	Female 809400004	12,5	3	3/8"	G	86,3	3,40	F	65,6	2,58	B	27,0	1,06	H	30,0	1,18	E	38,0	1,50	0,26	0,57
	M I12GS 3/8 BSP	Male 809400005							D	57,3	2,26	J	20,5	0,81	0,14	0,31						
1/2"	F IP12 1/2 BSP	Female 809400000	12,5	3	1/2"	G	111,1	4,37	F	69,4	2,73	B	27,0	1,06	H	30,0	1,18	E	38,0	1,50	0,26	0,56
	M I12GS 1/2 BSP	Male 809400001							D	61,1	2,41	J	20,5	0,81	0,14	0,31						
3/4"	F IP34 3/4 BSP	Female 809400014	20	4	3/4"	G	127,3	5,01	F	91,5	3,60	B	36,0	1,42	H	40,0	1,57	E	46,0	1,81	0,62	1,36
	M I34 3/4 BSP	Male 809400015							D	64,4	2,54	J	29,0	1,14	0,28	0,62						
1"	F IP100 3/4 BSP	Female 809400016	25	6	3/4"	G	151,2	5,95	F	103,5	4,07	B	41,0	1,61	H	45,0	1,77	E	54,0	2,13	0,90	1,98
	M I100 3/4 BSP	Male 809400017							D	69,5	2,74	J	34,3	1,35	0,40	0,88						
1"	F IP100 1" BSP	Female 809400018	25	6	1"	G	171,3	6,74	F	109,0	4,29	B	41,0	1,61	H	45,0	1,77	E	54,0	2,13	0,89	1,96
	M I100 1" BSP	Male 809400019							D	75,0	2,95	J	34,3	1,35	0,39	0,86						

Port description: FEMALE THREAD NPT (ANSI B.1.20.1)

BODY SIZE	Descriptive Code	Item Code	ISO DN	BG	PORT (A)	Overall Length	Length		Hex		Overall Diameter		Body Diameter		Weight							
							mm	inch	mm	inch	mm	inch	mm	inch	mm	inch	Kg	Lbs				
1/2"	F IP12 1/2 NPT	Female 809401000	12,5	3	1/2"	G	111,1	4,37	F	68,1	2,68	B	27,0	1,06	H	30,0	1,18	E	38,0	1,50	0,25	0,11
	M I12GS 1/2 NPT	Male 809401001							D	59,8	2,35	J	20,5	0,81	0,14	0,06						

Panel mounting on the sleeve: please contact, your local Stucchi sales engineer to get detailed dimensions.

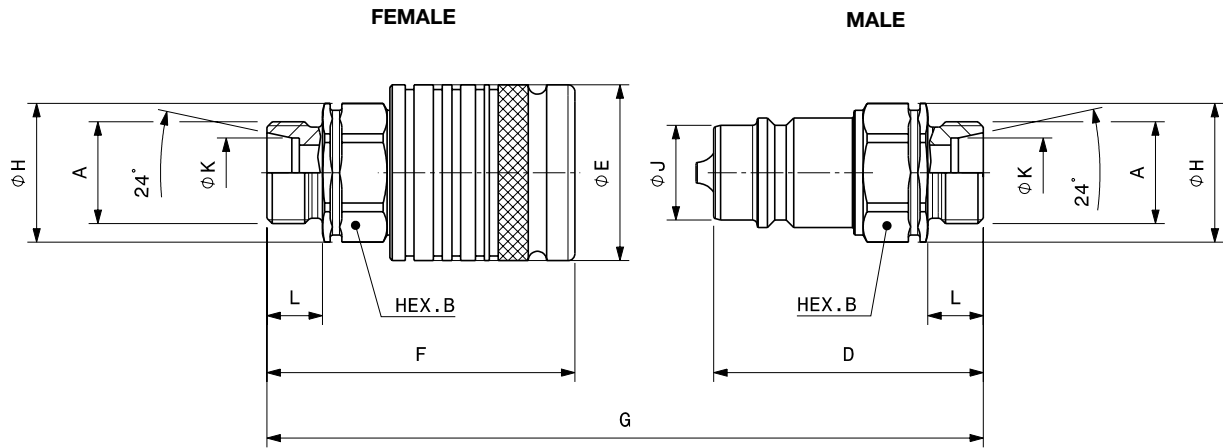

Port description: MALE THREAD METRIC L SERIES – 24° CONE (ISO 8434-1 & DIN 2353)

BODY SIZE	Descriptive Code	Item Code	ISO DN	BG	PORT (A)	Overall Length		Length		Hex		Overall Diameter		Diameter		Length		Body Diameter		Weight									
						mm	inch	mm	inch	mm	inch	mm	inch	mm	inch	mm	inch	mm	inch	Kg	Lbs								
1/4"	F IP14D L8	Female	809408010	6,3	1	M14 X 1,5	G	90,5	3,56	F	62,9	2,48	B	19,0	0,75	H	21,0	0,83	K	8,2	0,32	L	10,0	0,39	E	26,0	1,02	0,13	0,29
	M I14D L8	Male	809408011							D	45,0	1,77	J	11,9	0,47	0,05	0,10												
3/8"	F IP38 L8	Female	809408012	10	2	M14X 1,5	G	93,2	3,67	F	64,5	2,54	B	22,0	0,87	H	24,0	0,94	K	8,2	0,32	L	10,0	0,39	E	32,0	1,26	0,20	0,44
	M I38 L8	Male	809408013							D	46,3	1,82	J	17,3	0,68	0,07	0,15												
3/8"	F IP38 L10	Female	809408014	10	2	M16 X 1,5	G	95,2	3,75	F	65,5	2,58	B	22,0	0,87	H	24,0	0,94	K	10,2	0,40	L	11,0	0,43	E	32,0	1,26	0,20	0,44
	M I38 L10	Male	809408015							D	47,3	1,86	J	17,3	0,68	0,07	0,15												
1/2"	F IP12 L8	Female	809408002	12,5	3	M14 X 1,5	G	101,0	3,98	F	65,6	2,58	B	27,0	1,06	H	30,0	1,18	K	8,2	0,32	L	10,0	0,39	E	38,0	1,50	0,24	0,52
	M I12GS L8	Male	809408003							D	57,3	2,26	J	20,5	0,81	0,12	0,26												
1/2"	F IP12 L10	Female	809408006	12,5	3	M16 X 1,5	G	101,0	3,98	F	65,6	2,58	B	27,0	1,06	H	30,0	1,18	K	10,2	0,40	L	11,0	0,43	E	38,0	1,50	0,23	0,51
	M I12GS L10	Male	809408007							D	57,3	2,26	J	20,5	0,81	0,12	0,26												
1/2"	F IP12 L12	Female	809408000	12,5	3	M18x1,5	G	120,0	4,72	F	84,6	3,33	B	27,0	1,06	H	30,0	1,18	K	12,2	0,48	L	11,0	0,43	E	38,0	1,50	0,23	0,51
	M I12GS L12	Male	809408001							D	57,3	2,26	J	20,5	0,81	0,12	0,26												
1/2"	F IP12 L15	Female	809408004	12,5	3	M22x1,5	G	103,0	4,06	F	66,6	2,62	B	27,0	1,06	H	30,0	1,18	K	15,2	0,60	L	12,0	0,47	E	38,0	1,50	0,24	0,53
	M I12GS L15	Male	809408005							D	58,3	2,30	J	20,5	0,81	0,12	0,27												
1/2"	F IP12 L18	Female	809408008	12,5	3	M26x1,5	G	103,0	4,06	F	66,6	2,62	B	27,0	1,06	H	30,0	1,18	K	18,2	0,72	L	12,0	0,47	E	38,0	1,50	0,24	0,54
	M I12GS L18	Male	809408009							D	58,3	2,30	J	20,5	0,81	0,13	0,28												
3/4"	F IP34 L18	Female	809408026	20	4	M26x1,5	G	120,5	4,74	F	87,1	3,43	B	36,0	1,42	H	40,0	1,57	K	18,2	0,72	L	12,0	0,47	E	46,0	1,81	0,57	1,26
	M I34 L18	Male	809408027							D	60,0	2,36	J	29,0	1,14	0,24	0,52												
3/4"	F IP34 L22	Female	809408028	20	4	M30x2	G	122,4	4,82	F	88,0	3,46	B	36,0	1,42	H	40,0	1,57	K	22,0	0,87	L	14,0	0,55	E	46,0	1,81	0,57	1,25
	M I34 L22	Male	809408029							D	61,0	2,40	J	29,0	1,14	0,23	0,51												
1"	F IP100 L15	Female	809408030	25	6	M22x1,5	G	138,6	5,46	F	103,0	4,06	B	41,0	1,61	H	45,0	1,77	K	15,2	0,60	L	12,0	0,47	E	54,0	2,13	0,85	1,87
	M I100 L15	Male	809408031							D	69,0	2,72	J	34,3	1,35	0,35	0,76												
1"	F IP100 L18	Female	809408032	25	6	M26x1,5	G	138,6	5,46	F	103,0	4,06	B	41,0	1,61	H	45,0	1,77	K	18,2	0,72	L	12,0	0,47	E	54,0	2,13	0,85	1,87
	M I100 L18	Male	809408033							D	69,0	2,72	J	34,3	1,35	0,35	0,76												
1"	F IP100 L22	Female	809408034	25	6	M30x2	G	142,6	5,61	F	105,0	4,13	B	41,0	1,61	H	45,0	1,77	K	22,2	0,87	L	14,0	0,55	E	54,0	2,13	0,85	1,88
	M I100 L22	Male	809408035							D	71,0	2,80	J	34,3	1,35	0,35	0,77												
1"	F IP100 L28	Female	809408036	25	6	M36x2	G	142,6	5,61	F	105,0	4,13	B	41,0	1,61	H	45,0	1,77	K	28,2	1,11	L	14,0	0,55	E	54,0	2,13	0,85	1,88
	M I100 L28	Male	809408037							D	71,0	2,80	J	34,3	1,35	0,35	0,77												

Port description: MALE THREAD METRIC S SERIES – 24° CONE (ISO 8434-1 & DIN 2353)

BODY SIZE	Descriptive Code	Item Code	ISO DN	BG	PORT (A)	Overall Length		Length		Hex		Overall Diameter		Diameter		Length		Body Diameter		Weight									
						mm	inch	mm	inch	mm	inch	mm	inch	mm	inch	mm	inch	mm	inch	Kg	Lbs								
1/2"	F IP12 S10	Female	809409000	12,5	3	M18x1,5	G	103,0	4,06	F	66,6	2,62	B	27,0	1,06	H	30,0	1,18	K	10,2	0,40	L	12,0	0,47	E	38,0	1,50	0,24	0,53
	M I12GS S10	Male	809409001							D	58,3	2,30	J	20,5	0,81	0,12	0,27												
1/2"	F IP12 S12	Female	809409002	12,5	3	M20x1,5	G	103,0	4,06	F	66,6	2,62	B	27,0	1,06	H	30,0	1,18	K	12,2	0,48	L	12,0	0,47	E	38,0	1,50	0,24	0,53
	M I12GS S12	Male	809409003							D	58,3	2,30	J	20,5	0,81	0,13	0,28												
1/2"	F IP12 S14	Female	809409004	12,5	3	M22x1,5	G	107,0	4,21	F	68,6	2,70	B	27,0	1,06	H	30,0	1,18	K	14,2	0,56	L	14,0	0,55	E	38,0	1,50	0,25	0,54
	M I12GS S14	Male	809409005							D	60,3	2,37	J	20,5	0,81	0,13	0,29												

Panel mounting on the sleeve: please contact, your local Stucchi sales engineer to get detailed dimensions.

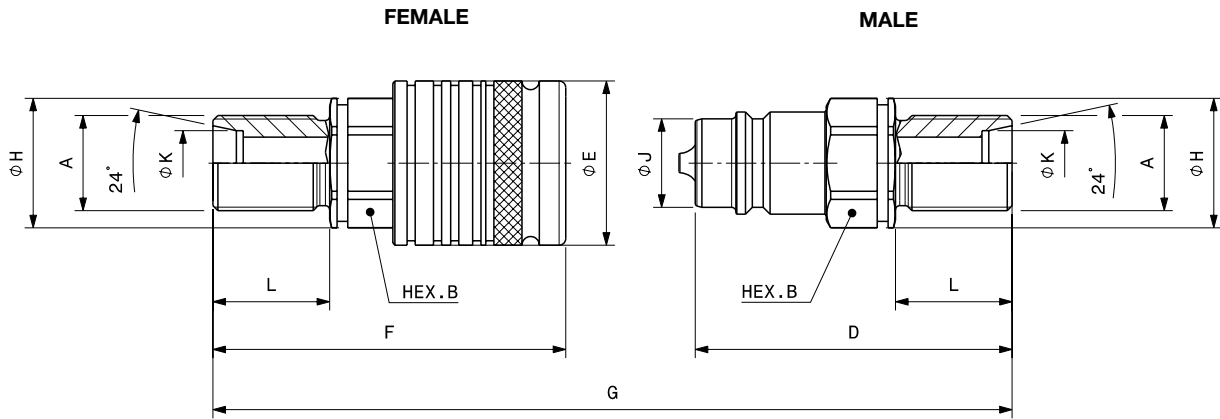
Port description: MALE THREAD METRIC L SCHOTT – BULKHEAD SERIES – 24° CONE (ISO 8434-1 & DIN 2353)

BODY SIZE	Descriptive Code	Item Code	ISO DN	BG	PORT (A)	Overall Length		Length		Hex		Overall Diameter		Diameter		Length		Body Diameter		Weight									
						mm	inch	mm	inch	mm	inch	mm	inch	mm	inch	mm	inch	mm	inch	Kg	Lbs								
1/4"	F IP14D L8 SCHOTT	Female	809410010	6,3	1	M14 X 1,5	G	120,5	4,74	F	77,9	3,07	B	19,0	0,75	H	21,0	0,83	K	8,2	0,32	L	25,0	0,98	E	26,0	1,02	0,14	0,31
	M IP14D L8 SCHOTT	Male	809410011							D	60,0	2,36	J	11,9	0,47	0,06	0,13												
3/8"	F IP38 L8 SCHOTT	Female	809410012	10	2	M14 X 1,5	G	123,2	4,85	F	79,5	3,13	B	22,0	0,87	H	24,0	0,94	K	8,2	0,32	L	25,0	0,98	E	32,0	1,26	0,21	0,46
	M IP38 L8 SCHOTT	Male	809410013							D	61,3	2,41	J	17,3	0,68	0,08	0,18												
3/8"	F IP38 L10 SCHOTT	Female	809410014	10	2	M16 X 1,5	G	125,2	4,93	F	80,5	3,17	B	22,0	0,87	H	24,0	0,94	K	10,2	0,40	L	26,0	1,02	E	32,0	1,26	0,21	0,47
	M IP38 L10 SCHOTT	Male	809410015							D	62,3	2,45	J	17,3	0,68	0,08	0,18												
1/2"	F IP12 L8 SCHOTT	Female	809410002	12,5	3	M14 X 1,5	G	133,0	5,24	F	81,6	3,21	B	27,0	1,06	H	30,0	1,18	K	8,2	0,32	L	26,0	1,02	E	38,0	1,50	0,25	0,55
	M IP12 L8 SCHOTT	Male	809410003							D	73,3	2,89	J	20,5	0,81	0,13	0,29												
1/2"	F IP12 L10 SCHOTT	Female	809410006	12,5	3	M16 X 1,5	G	131,0	5,16	F	80,6	3,17	B	27,0	1,06	H	30,0	1,18	K	10,2	0,40	L	26,0	1,02	E	38,0	1,50	0,25	0,54
	M IP12 L10 SCHOTT	Male	809410007							D	72,3	2,85	J	20,5	0,81	0,13	0,29												
1/2"	F IP12 L12 SCHOTT 30	Female	809410000	12,5	3	M18 X 1,5	G	139,0	5,47	F	84,6	3,33	B	27,0	1,06	H	30,0	1,18	K	12,2	0,48	L	30,0	1,18	E	38,0	1,50	0,25	0,56
	M IP12 L12 SCHOTT 30	Male	809410001							D	76,3	3,00	J	20,5	0,81	0,14	0,31												
1/2"	F IP12 L15 SCHOTT	Female	809410004	12,5	3	M22 X 1,5	G	133,0	5,24	F	81,6	3,21	B	27,0	1,06	H	30,0	1,18	K	15,2	0,60	L	27,0	1,06	E	38,0	1,50	0,27	0,59
	M IP12 L15 SCHOTT	Male	809410005							D	73,3	2,89	J	20,5	0,81	0,15	0,34												
1/2"	F IP12 L18 SCHOTT	Female	809410008	12,5	3	M26 X 1,5	G	133,0	5,24	F	81,6	3,21	B	27,0	1,06	H	30,0	1,18	K	18,2	0,72	L	27,0	1,06	E	38,0	1,50	0,28	0,62
	M IP12 L18 SCHOTT	Male	809410009							D	73,3	2,89	J	20,5	0,81	0,16	0,36												
3/4"	F IP34 L15 SCHOTT	Female	809410024	20	4	M22 X 1,5	G	148,5	5,85	F	101,1	3,98	B	36,0	1,42	H	40,0	1,57	K	15,2	0,60	L	27,0	1,06	E	46,0	1,81	0,59	1,29
	M IP34 L15 SCHOTT	Male	809410025							D	74,0	2,91	J	29,0	1,14	0,25	0,55												
3/4"	F IP34 L22 SCHOTT 36	Female	809410028	20	4	M30 X 2	G	166,5	6,56	F	110,1	4,33	B	36,0	1,42	H	40,0	1,57	K	22,0	0,87	L	36,0	1,42	E	46,0	1,81	0,63	1,38
	M IP34 L22 SCHOTT 36	Male	809410029							D	83,0	3,27	J	29,0	1,14	0,29	0,64												

POPPET

Port description: MALE THREAD METRIC S SCHOTT – BULKHEAD SERIES – 24° CONE (ISO 8434-1 & DIN 2353)

BODY SIZE	Descriptive Code	Item Code	ISO DN	BG	PORT (A)	Overall Length		Length		Hex		Overall Diameter		Diameter		Length		Body Diameter		Weight									
						mm	inch	mm	inch	mm	inch	mm	inch	mm	inch	mm	inch	mm	inch	Kg	Lbs								
1/2"	F IP12 S10 SCHOTT	Female	809411000	12,5	3	M18 X 1,5	G	133,0	5,24	F	81,6	3,21	B	27,0	1,06	H	30,0	1,18	K	10,2	0,40	L	27,0	1,06	E	38,0	1,50	0,27	0,60
	M IP12 S10 SCHOTT	Male	809411001							D	73,3	2,89	J	20,5	0,81	0,16	0,35												
1/2"	F IP12 S12 SCHOTT	Female	809411002	12,5	3	M20 X 1,5	G	133,0	5,24	F	81,6	3,21	B	27,0	1,06	H	30,0	1,18	K	12,2	0,48	L	27,0	1,06	E	38,0	1,50	0,27	0,59
	M IP12 S12 SCHOTT	Male	809411003							D	73,3	2,89	J	20,5	0,81	0,15	0,33												
1/2"	F IP12 S16 SCHOTT	Female	809411006	12,5	3	M24 X 1,5	G	137,0	5,39	F	83,6	3,29	B	27,0	1,06	H	30,0	1,18	K	16,2	0,64	L	29,0	1,14	E	38,0	1,50	0,28	0,62
	M IP12 S16 SCHOTT	Male	809411007							D	75,3	2,96	J	20,5	0,81	0,17	0,37												
3/4"	F IP34 S16 SCHOTT	Female	809411010	20	4	M24 X 1,5	G	152,5	6,00	F	103,1	4,06	B	36,0	1,42	H	40,0	1,57	K	16,2	0,64	L	29,0	1,14	E	46,0	1,81	0,60	1,33
	M IP34 S16 SCHOTT	Male	809411011							D	76,0	2,99	J	29,0	1,14	0,27	0,59												
3/4"	F IP34 S20 SCHOTT	Female	809411012	20	4	M30 X 2	G	166,5	6,56	F	110,1	4,33	B	36,0	1,42	H	40,0	1,57	K	20,0	0,79	L	36,0	1,42	E	46,0	1,81	0,65	1,43
	M IP34 S20 SCHOTT	Male	809411013							D	83,0	3,27	J	29,0	1,14	0,31	0,69												
1"	F IP100 S20 SCHOTT 38	Female	809411014	25	6	M30 X 2	G	190,6	7,50	F	129,0	5,08	B	41,0	1,61	H	45,0	1,77	K	20,2	0,80	L	38,0	1,50	E	54,0	2,13	0,94	2,07
	M IP100 S20 SCHOTT 38	Male	809411015							D	95,0	3,74	J	34,3	1,35	0,44	0,96												
1"	F IP100 S25 SCHOTT	Female	809411016	25	6	M36 X 2	G	190,6	7,50	F	129,0	5,08	B	41,0	1,61	H	45,0	1,77	K	25,2	0,99	L	38,0	1,50	E	54,0	2,13	0,98	2,16
	M IP100 S25 SCHOTT	Male	809411017							D	95,0	3,74	J	34,3	1,35	0,48	1,06												

Panel mounting on the sleeve: please contact, your local Stucchi sales engineer to get detailed dimensions.

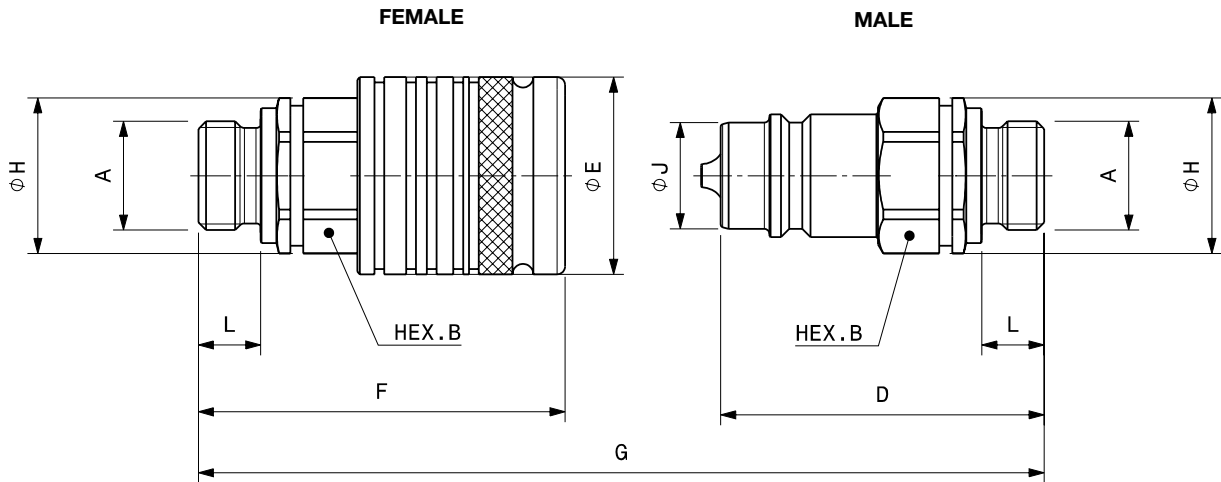

Port description: MALE THREAD BSPP (DIN3852/A)

BODY SIZE	Descriptive Code	Item Code	ISO DN	BG	PORT (A)	Overall Length	Length		Length		Hex		Overall Diameter		Overall Diameter		Weight								
							mm	inch	mm	inch	mm	inch	mm	inch	mm	inch	mm	inch	Kg	Lbs					
3/8"	FIP38 3/8 BSP EST - A	Female 809400012	10	2	3/8"	G	102,2	4,02	F	69,0	2,72	L	12,0	0,47	B	22,0	0,87	H	24,0	0,94	E	32,0	1,26	0,42	0,91
	M 138 3/8 BSP EST - A	Male 809400013							D	50,8	2,00										J	17,3	0,68	0,08	0,18
1/2"	FIP12 1/2 BSP EST - A	Female 809400002	12,5	3	1/2"	G	111,0	4,37	F	70,6	2,78	L	12,0	0,47	B	27,0	1,06	H	30,0	1,18	E	38,0	1,50	0,28	0,62
	M 112GS 1/2 BSP EST - A	Male 809400003							D	62,3	2,45										J	20,5	0,81	0,14	0,30

Panel mounting on the sleeve: please contact, your local Stucchi sales engineer to get detailed dimensions.

IRS version

IRS Series is the ISO 7241 A interchangeable quick coupling with single body.

It is available with poppet valving style (IRS-VA version) and with ball valving style (IRS-A version).

The specific datasheet is available upon request; please contact Stucchi Technical Support for additional information.





SPARE KIT SEAL FOR FEMALE

Repair kit / OR+BK		
Body Size	Description	Part Number
1/4"	F IP14D	815700924
3/8"	F IP38	815700926
1/2"	F IP12	815700928
3/4"	F IP34	815700930
1"	F IP100	815700932

O-Ring in NBR
BackUp in Teflon®

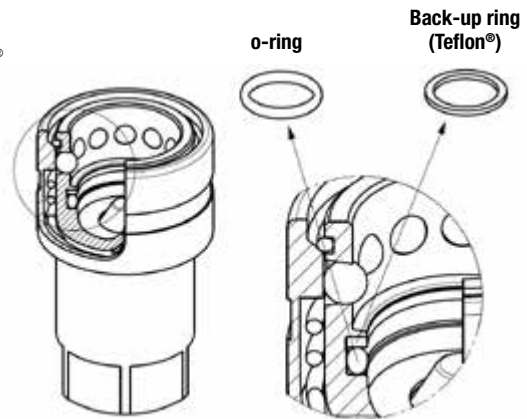

PROTECTIVE CAPS FOR I-IP SERIES

Protective caps are always recommended to protect the couplings from damage, dirt inclusion, and will increase the product life. This is particularly important in agriculture applications where exposure to weather and aggregate materials are common.

The protective caps for I-IP series are manufactured in plastic with connection lanyard (standard color red, other colors available upon request). A flip cap version is also available for the size 1/2".

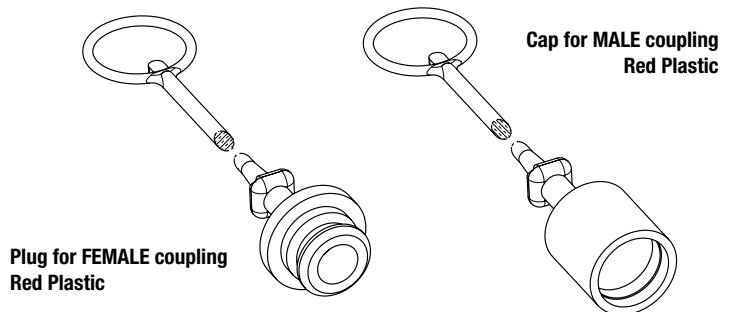

Body Size/Description	Protective Cap		Material/Color
	Part Number	Part Number	
3/8" IP38	Plug for Female 815000014	Cap for Male 815000015	Plastic/Red
1/2" IP12	815000004	815000005	Plastic/Red
3/4" IP34	815000016	815000017	Plastic/Red
1" IP100	815000018	815000019	Plastic/Red

Flip cap for FEMALE coupling
Plastic

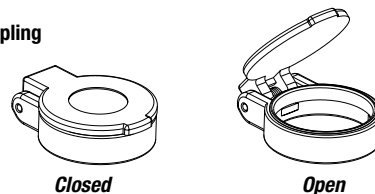

Body Size/Description	Protective Cap		Material/Color
	Part Number	Part Number	
1/2" IP12	Plug for Female 815200004		Plastic/Red



IRSERIES

INTERCHANGE > With similar couplings, ISO 7241 A (size 1/2" only)



Stucchi®



TECHNICAL FEATURES AND OPTIONS

Interchange With similar couplings, ISO 7241 A (size 1/2" only)	Sealing description Nitrile NBR	Connection system Single acting sleeve
Available sizes from 1/4" to 1"	Material/treatment Carbon steel /Cr3	Available threads BSP - NPT
Operating pressure Up to 300 bar	Locking mechanism Locking Ball system	Flow rate Up to 150 l/min
Temperature (°C) -20° / +100°	Valving style Ball	Connection under pressure Connection: not allowed Disconnection: not allowed

BENEFITS

- Ball valves in hardened steel provide a good wearing resistance.
- Compact slim design.
- Simple to use.

HOW TO USE

- Before to connect, clean the mating surface of the couplings to avoid dirt inclusion in the circuit.
- To connect pull back the sleeve of the female coupling, align the female with the male coupling and push one into the other until both halves are fully connected and release the sleeve.
- To disconnect push back the sleeve of the female coupling, pull out the mating half.

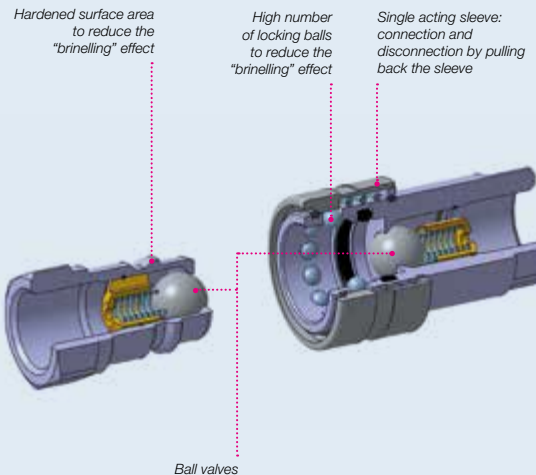
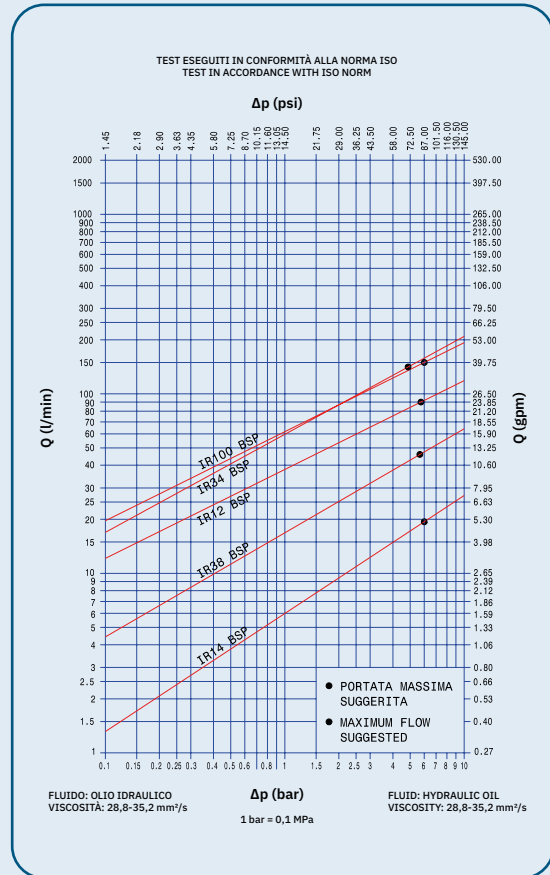

MAIN APPLICATIONS





PERFORMANCES

Size		Series/Size	Max. flow suggested		Connect force		Disconnect force		Spillage*
Inch	mm (ISO)		l/min	gpm	N	lbf	N	lbf	ml
1/4		IR14	20	5,30	50	11,25	45	10,13	0,13
3/8		IR38	46	12,19	125	28,13	45	10,13	0,45
1/2	12,5	IR12**	90	23,85	80	18,00	50	11,25	2,30
3/4		IR34	148	39,22	190	42,75	45	10,13	4,50
1		IR100	150	39,75	100	22,50	45	10,13	6,00

Size	Series/Size	Max. operating pressure						Burst pressure					
		Coupled		Male		Female		Coupled		Male		Female	
Inch		MPa	psi	MPa	psi	MPa	psi	MPa	psi	MPa	psi	MPa	psi
1/4	IR14	30	4350	30	4350	30	4350	100	14500	100	14500	100	14500
3/8	IR38	30	4350	30	4350	30	4350	100	14500	100	14500	90	13050
1/2	IR12**	25	3625	20	2900	20	2900	80	11600	55	7975	55	7975
3/4	IR34	25	3625	20	2900	25	3625	100	14500	60	8700	90	13050
1	IR100	20	2900	20	2900	20	2900	80	11600	60	8700	80	11600

* Spillage is an indicative value of the fluid loss during disconnection (according to ISO norm test method).

** Size 1/2" is ISO7241-1/A interchangeable.

Temperature range:

Seals in NBR (Nitrile): from -20 °C to +100 °C (from -4 °F to +212 °F).

Please read carefully Instructions and warnings for proper selection of the products.

Different possible configurations:

TIC version, shielded poppet to eliminate flow-checking when used with connect-under-pressure competitor couplers.

⚠ WARNING

A defect, a wrong choice or an improper use of products, can cause injury to persons, animals and objects.

Never connect or disconnect with dynamic pressure (e.g. pump on).

Do not couple-uncouple with flow and/or pressure in the circuit.

Do not couple-uncouple when the temperature inside of the circuit is higher than 80 °C (176 °F).

Check the maximum allowable working pressure of the port in use.

Make sure that the medium used is compatible with seal and material as indicated for each series.

In case of doubt please contact Stucchi Technical Support.

The interchangeability is mentioned under the assumption that the manufacturer of the considered products has not changed any dimension.

It is MANDATORY to read and closely follow the instructions. Last updated version always apply at time of installation, see latest written Instructions on Stucchi website (stucchigroup.com) before selecting or using Stucchi products.

OVERALL DIMENSIONS

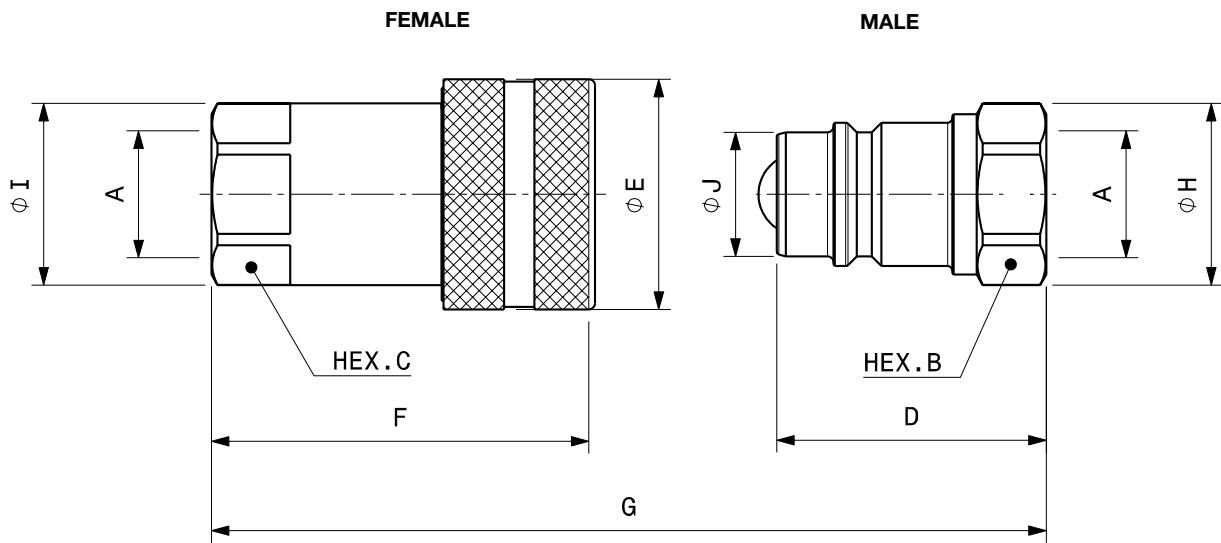

Port description: FEMALE THREAD BSPP (ISO 1179-1)

BODY SIZE	Descriptive Code	Item Code	ISO DN	PORT (A)	Overall Length		Length		Hex		Overall Diameter		Body Diameter		Weight						
					mm	inch	mm	inch	mm	inch	mm	inch	mm	inch	Kg	Lbs					
1/4"	F IR14 BSP	Female 800000000	-	1/4"	G	64,4	2,54	F	48,9	1,93	C	19,0	0,75	I	21,0	0,83	E	27,0	1,06	0,11	0,25
	M IR14 BSP	Male 800000001						D	32,5	1,28	B	19,0	0,75	H	22,0	0,87	J	14,2	0,56	0,04	0,08
3/8"	F IR38 BSP	Female 800000002	-	3/8"	G	76,3	3,00	F	58,3	2,30	C	24,0	0,94	I	26,5	1,04	E	34,0	1,34	0,22	0,49
	M IR38 BSP	Male 800000003						D	38,0	1,50	B	24,0	0,94	H	27,7	1,09	J	19,0	0,75	0,08	0,17
1/2"	F IR12 BSP	Female 800000004	12,5	1/2"	G	86,3	3,40	F	63,3	2,49	C	27,0	1,06	I	30,0	1,18	E	38,0	1,50	0,24	0,54
	M IR12 BSP	Male 800000005						D	44,5	1,75	B	27,0	1,06	H	30,0	1,18	J	20,5	0,81	0,10	0,21
3/4"	F IR34 BSP	Female 800000006	-	3/4"	G	118,3	4,66	F	90,3	3,56	C	38,0	1,50	I	43,0	1,69	E	48,0	1,89	0,68	1,50
	M IR34 BSP	Male 800000007						D	59,0	2,32	B	36,0	1,42	H	38,5	1,52	J	26,9	1,06	0,19	0,43
3/4"	F IR34FA BSP	Female 820000020 *	-	3/4"	G	106,5	4,19	F	82,0	3,23	C	38,0	1,50	I	41,8	1,65	E	46,3	1,82	0,50	1,10
	M IR34FA BSP	Male 820000021 *						D	53,0	2,09	B	34,0	1,34	H	39,1	1,54	J	28,0	1,10	0,19	0,41
1"	F IR100 BSP	Female 800000008	-	1"	G	132,8	5,23	F	99,6	3,92	C	45,0	1,77	I	52,0	2,05	E	54,0	2,13	0,87	1,92
	M IR100 BSP	Male 800000009						D	66,1	2,60	B	41,0	1,61	H	44,8	1,76	J	31,4	1,24	0,30	0,66

* alternative interchange

IR-TIC Version designed for high backflow

BODY SIZE	Descriptive Code	Item Code	ISO DN	PORT (A)	Overall Length		Length		Hex		Overall Diameter		Body Diameter		Weight						
					mm	inch	mm	inch	mm	inch	mm	inch	mm	inch	Kg	Lbs					
1/2"	M IR12TIC BSP	Male 800000011	12,5	1/2"	G	86,3	3,40	D	47,0	1,85	B	27	1,06	H	30,0	1,18	J	20,5	0,81	0,10	0,21

TIC VERSION: shielded valving to prevent flow-checking when used with connect-under-pressure competitor couplers.

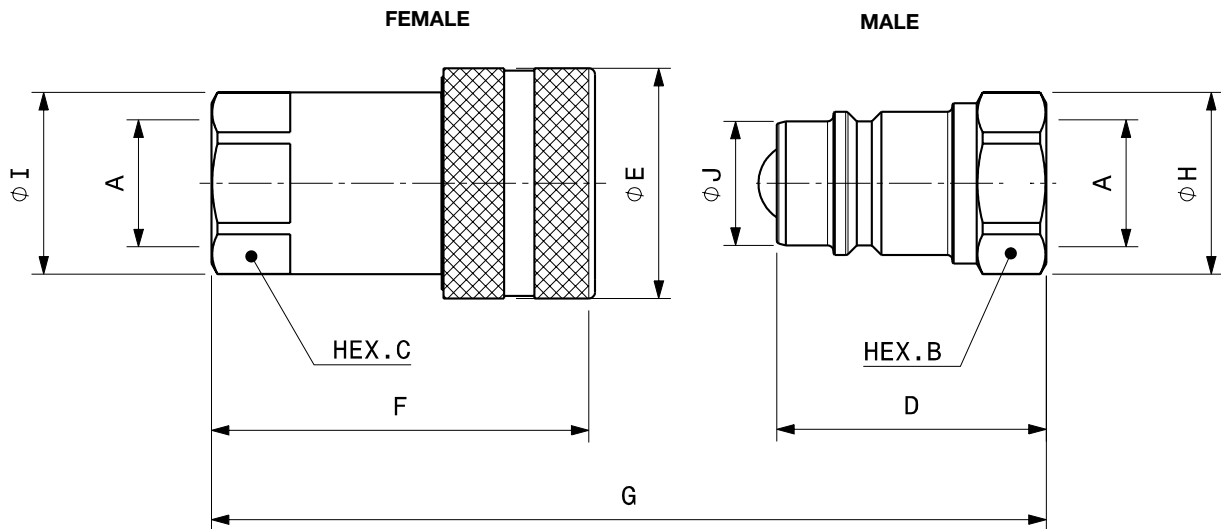

Port description: FEMALE THREAD NPT (ANSI B1.20.1)

BODY SIZE	Descriptive Code	Item Code	ISO DN	PORT (A)	Overall Length		Length		Hex		Overall Diameter		Body Diameter		Weight						
					mm	inch	mm	inch	mm	inch	mm	inch	mm	inch	Kg	Lbs					
1/4"	F IR14 NPT	Female 800001000	-	1/4"	G	64,4	2,54	F	48,9	1,93	C	19,0	0,75	I	21,0	0,83	E	27,0	1,06	0,13	0,28
	M IR14 NPT	Male 800001001						D	32,5	1,28	B	19,0	0,75	H	22,0	0,87	J	14,2	0,56	0,04	0,09
3/8"	F IR38 NPT	Female 800001002	-	3/8"	G	76,3	3,00	F	58,3	2,30	C	24,0	0,94	I	26,5	1,04	E	34,0	1,34	0,22	0,49
	M IR38 NPT	Male 800001003						D	38,0	1,50	B	24,0	0,94	H	27,7	1,09	J	19,0	0,75	0,08	0,18
1/2"	F IR12 NPT	Female 800001004	12,5	1/2"	G	86,3	3,40	F	63,3	2,49	C	27,0	1,06	I	30,0	1,18	E	38,0	1,50	0,28	0,61
	M IR12 NPT	Male 800001005						D	44,5	1,75	B	27,0	1,06	H	30,0	1,18	J	20,5	0,81	0,09	0,20
3/4"	F IR34 NPT	Female 800001006	-	3/4"	G	118,3	4,66	F	90,3	3,56	C	38,0	1,50	I	43,0	1,69	E	48,0	1,89	0,70	1,54
	M IR34 NPT	Male 800001007						D	59,0	2,32	B	36,0	1,42	H	38,5	1,52	J	26,9	1,06	0,21	0,47
1"	F IR100 NPT	Female 800001008	-	1"	G	132,8	5,23	F	99,6	3,92	C	45,0	1,77	I	52,0	2,05	E	54,0	2,13	0,89	1,97
	M IR100 NPT	Male 800001009						D	66,1	2,60	B	41,0	1,61	H	44,8	1,76	J	31,4	1,24	0,30	0,66

IR-TIC Version designed for high backflow

BODY SIZE	Descriptive Code	Item Code	ISO DN	PORT (A)	Overall Length		Length		Hex		Overall Diameter		Body Diameter		Weight						
					mm	inch	mm	inch	mm	inch	mm	inch	mm	inch	Kg	Lbs					
1/2"	M IR12TIC NPT	Male 800001011	12,5	1/2"	G	86,3	3,40	D	47,0	1,85	B	27,0	1,06	H	30,0	1,18	J	20,5	0,81	0,10	0,21

TIC VERSION: shielded valving to prevent flow-checking when used with connect-under-pressure competitor couplers.



SPARE KIT SEAL FOR FEMALE

Repair kit / OR		
Body Size	Description	Part Number
1/4"	F IR14	815700348
3/8"	F IR38	815700350
1/2"	F IR12	815700352
3/4"	F IR34	815700354
3/4"	F IR34 FA	815700734
1"	F IR100	815700356

O-Ring in NBR

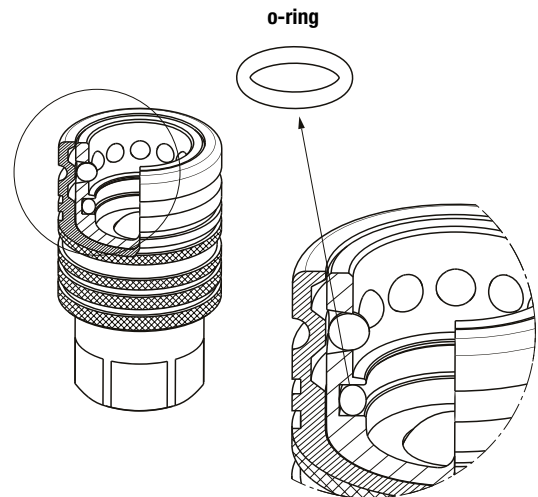

PROTECTIVE CAPS FOR IR SERIES

Protective caps are always recommended to protect the couplings from damage, dirt inclusion, and will increase the product life. This is particularly important in agriculture applications where exposure to weather and aggregate materials are common. The protective caps for IR series are manufactured in plastic with connection lanyard (standard color red, other colors available upon request).

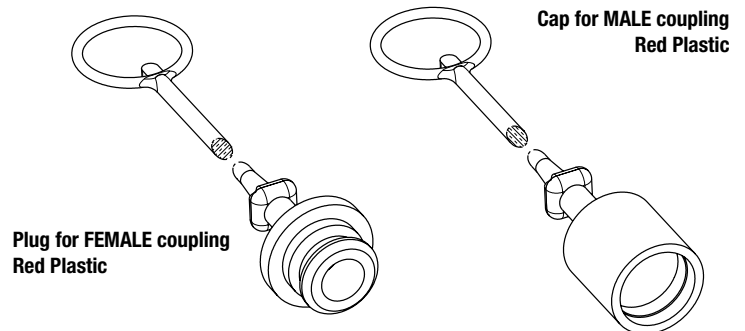

Body Size/Description		Protective Cap		Material/Color
		Plug for Female	Cap for Male	
1/4"	IR14	815000000	815000001	Plastic/Red
3/8"	IR38	815000002	815000003	Plastic/Red
1/2"	IR12	815000004	815000005	Plastic/Red
3/4"	IR34	815000006	815000007	Plastic/Red
1"	IR100	815000008	815000009	Plastic/Red



IR-VSERIES

INTERCHANGE > With similar couplings IR series, ISO 7241 SERIES "A" (SIZE 1/2" only)



TECHNICAL FEATURES AND OPTIONS

Interchange With similar couplings IR series, ISO 7241 SERIES "A" (SIZE 1/2" only)	Sealing description Nitrile NBR	Connection system Single acting sleeve
Available sizes from 1/4" to 1"	Material/treatment Carbon steel /Cr3	Available threads BSP - NPT - SAE
Operating pressure Up to 300 bar	Locking mechanism Ball Locking	Flow rate Up to 200 l/min
Temperature (°C) -20° / +100°	Valving style Poppet	Connection under pressure Connection: not allowed Disconnection: not allowed

BENEFITS

- The poppet valve with elastomer seal provides maximum sealing of the couplings when disconnected.
- Shape of internal parts is designed to reduce turbulence and pressure drop.
- Compact slim design.
- Simple to use.

HOW TO USE

- Before to connect, clean the mating surface of the couplings to avoid dirt inclusion in the circuit.
- To connect pull back the sleeve of the female coupling, align the female with the male coupling and push one into the other until both halves are fully connected and release the sleeve.
- To disconnect push back the sleeve of the female coupling, pull out the mating half.

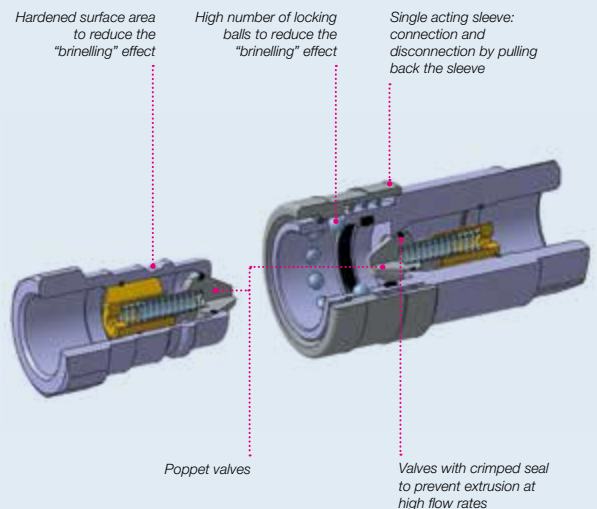
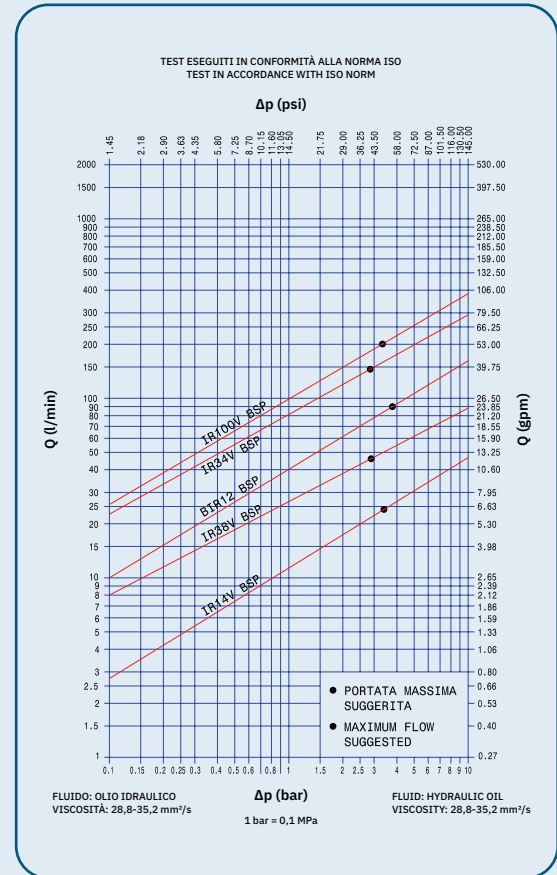

MAIN APPLICATIONS



POPPET



PERFORMANCES

Size		Series/Size	Max. flow suggested		Connect force		Disconnect force		Spillage*
Inch	mm (ISO)		l/min	gpm	N	lbf	N	lbf	ml
1/4		IR14V	24	6,36	80	18,00	40	9,00	0,33
3/8		IR38V	46	12,19	120	27,00	35	7,88	1,30
1/2	12,5	BIR12**	90	23,85	70	15,75	55	12,38	2,10
3/4		IR34V	148	39,22	175	39,38	45	10,13	4,20
1		IR100V	200	53,00	210	47,25	65	14,63	5,50

Size	Series/Size	Max. operating pressure						Burst pressure					
		Coupled		Male		Female		Coupled		Male		Female	
Inch		MPa	psi	MPa	psi	MPa	psi	MPa	psi	MPa	psi	MPa	psi
1/4	IR14V	30	4350	30	4350	30	4350	100	14500	100	14500	100	14500
3/8	IR38V	30	4350	30	4350	30	4350	100	14500	100	14500	100	14500
1/2	BIR12**	25	3625	25	3625	25	3625	80	11600	80	11600	100	14500
3/4	IR34V	25	3625	25	3625	25	3625	100	14500	90	13050	100	14500
1	IR100V	20	2900	20	2900	20	2900	80	11600	80	11600	80	11600

* Spillage is an indicative value of the fluid loss during disconnection (according to ISO norm test method).

** Size 1/2" is ISO7241-1/A interchangeable.

Different possible configurations:

PL version (free flow without valve): available upon request.
SAE thread upon request.

Temperature range:

Standard seals in NBR (Nitrile): from -20 °C to +100 °C (from -4 °F to +212 °F).
Upon request seals in VITON®: from -15°C to +180°C (from +5 °F to +356 °F).
Please read carefully Instructions and warnings for proper selection of the products.



WARNING

A defect, a wrong choice or an improper use of products, can cause injury to persons, animals and objects.

Never connect or disconnect with dynamic pressure (e.g. pump on).

Do not couple-uncouple with flow and/or pressure in the circuit.

Do not couple-uncouple when the temperature inside of the circuit is higher than 80 °C (176 °F).

Check the maximum allowable working pressure of the port in use.

Make sure that the medium used is compatible with seal and material as indicated for each series.

In case of doubt please contact Stucchi Technical Support.

The interchangeability is mentioned under the assumption that the manufacturer of the considered products has not changed any dimension.

It is mandatory to carefully read and closely follow the instructions before selecting or using any Stucchi products.

Always refer to the version uploaded in the Instructions and warning section of stucchigroup.com website for the latest release.

For specific, product-related, instructions, please contact Stucchi technical service.

OVERALL DIMENSIONS

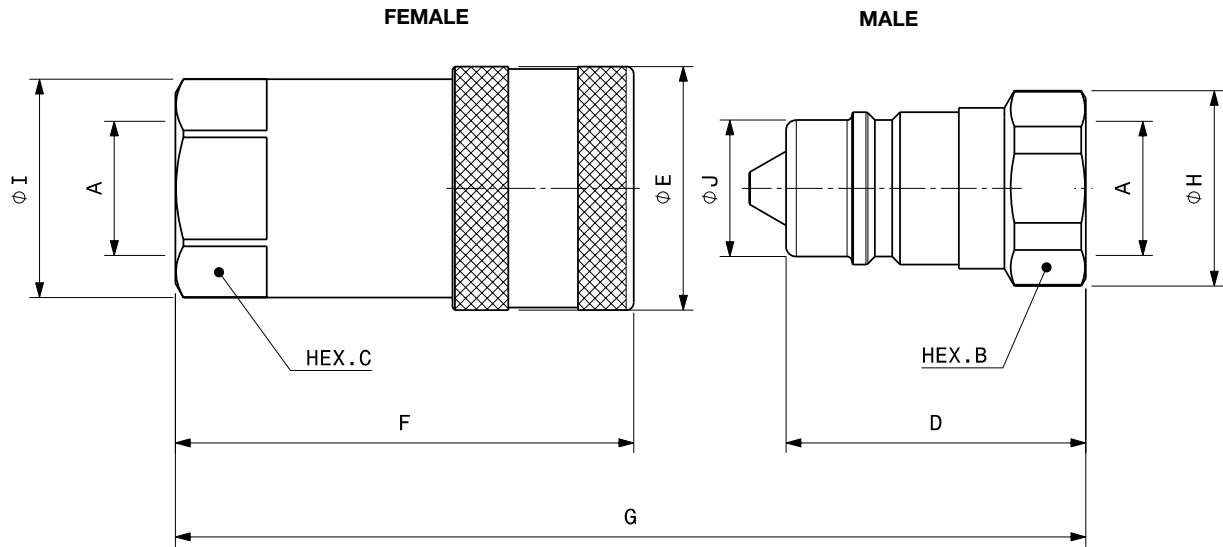

Port description: FEMALE THREAD BSPP (ISO 1179-1)

BODY SIZE	Descriptive Code	Item Code	ISO DN	PORT (A)	Overall Length		Length		Hex		Overall Diameter		Body Diameter		Weight						
					mm	inch	mm	inch	mm	inch	mm	inch	mm	inch	Kg	Lbs					
1/4"	F IR14V BSP	Female 800100000	-	1/4"	G	65,9	2,59	F	50,4	1,98	C	19,0	0,75	I	21,0	0,83	E	27,0	1,06	0,12	0,25
	M IR14V BSP	Male 800100001						D	32,5	1,28	B	19,0	0,75	H	22,0	0,87	J	14,2	0,56	0,04	0,08
3/8"	F IR38V BSP	Female 800100002	-	3/8"	G	76,3	3,00	F	58,3	2,30	C	24,0	0,94	I	26,5	1,04	E	34,0	1,34	0,22	0,47
	M IR38V BSP	Male 800100003						D	38,0	1,50	B	24,0	0,94	H	27,7	1,09	J	19,0	0,75	0,07	0,16
1/2"	F IR12 BSP	Female 800500004	12,5	1/2"	G	86,3	3,40	F	63,3	2,49	C	27,0	1,06	I	30,0	1,18	E	38,0	1,50	0,25	0,54
	M IR12 BSP	Male 800500005						D	44,5	1,75	B	27,0	1,06	H	29,0	1,14	J	20,5	0,81	0,08	0,19
3/4"	F IR34V BSP	Female 800100004	-	3/4"	G	118,3	4,66	F	90,3	3,56	C	38,0	1,50	I	43,0	1,69	E	48,0	1,89	0,68	1,50
	M IR34V BSP	Male 800100005						D	59,0	2,32	B	36,0	1,42	H	38,5	1,52	J	26,9	1,06	0,19	0,41
3/4"	F IR34VFA BSP	Female 820000022 *	-	3/4"	G	106,5	4,19	F	82,0	3,23	C	38,0	1,50	I	41,8	1,65	E	46,3	1,82	0,49	1,07
	M IR34VFA BSP	Male 820000023 *						D	53,0	2,09	B	34,0	1,34	H	39,1	1,54	J	28,0	1,10	0,18	0,40
1"	F IR100V BSP	Female 800100006	-	1"	G	128,8	5,07	F	97,6	3,84	C	45,0	1,77	I	52,0	2,05	E	54,0	2,13	0,83	1,83
	M IR100V BSP	Male 800100007						D	64,1	2,52	B	41,0	1,61	H	44,8	1,76	J	31,4	1,24	0,26	0,58

* alternative interchange

Port description: FEMALE THREAD NPT (ANSI B1.20.1)

BODY SIZE	Descriptive Code	Item Code	ISO DN	PORT (A)	Overall Length		Length		Hex		Overall Diameter		Body Diameter		Weight						
					mm	inch	mm	inch	mm	inch	mm	inch	mm	inch	Kg	Lbs					
1/4"	F IR14V NPT	Female 800101000	-	1/4"	G	65,9	2,59	F	50,4	1,98	C	19,0	0,75	I	21,0	0,83	E	27,0	1,06	0,13	0,28
	M IR14V NPT	Male 800101001						D	32,5	1,28	B	19,0	0,75	H	22,0	0,87	J	14,2	0,56	0,04	0,09
3/8"	F IR38V NPT	Female 800101002	-	3/8"	G	76,3	3,00	F	58,3	2,30	C	24,0	0,94	I	26,5	1,04	E	34,0	1,34	0,22	0,49
	M IR38V NPT	Male 800101003						D	38,0	1,50	B	24,0	0,94	H	27,7	1,09	J	19,0	0,75	0,08	0,18
1/2"	F IR12 NPT	Female 800501004	12,5	1/2"	G	86,3	3,40	F	63,3	2,49	C	27,0	1,06	I	30,0	1,18	E	38,0	1,50	0,25	0,54
	M IR12 NPT	Male 800501005						D	44,5	1,75	B	27,0	1,06	H	29,0	1,14	J	20,5	0,81	0,08	0,19
3/4"	F IR34V NPT	Female 800101004	-	3/4"	G	118,3	4,66	F	90,3	3,56	C	38,0	1,50	I	43,0	1,69	E	48,0	1,89	0,66	1,46
	M IR34V NPT	Male 800101005						D	59,0	2,32	B	36,0	1,42	H	38,5	1,52	J	26,9	1,06	0,19	0,41
1"	F IR100V NPT	Female 800101006	-	1"	G	128,8	5,07	F	97,6	3,84	C	45,0	1,77	I	52,0	2,05	E	54,0	2,13	0,86	1,90
	M IR100V NPT	Male 800101007						D	64,1	2,52	B	41,0	1,61	H	44,8	1,76	J	31,4	1,24	0,28	0,61



SPARE KIT SEAL FOR FEMALE

Repair kit / OR		
Body Size	Description	Part Number
1/4"	F IR-V14	815700348
3/8"	F IR-V38	815700350
1/2"	F IR-V12	815700352
3/4"	F IR-V34	815700354
3/4"	F IR34V FA	815700734
1"	F IR-V100	815700356

O-Ring in NBR

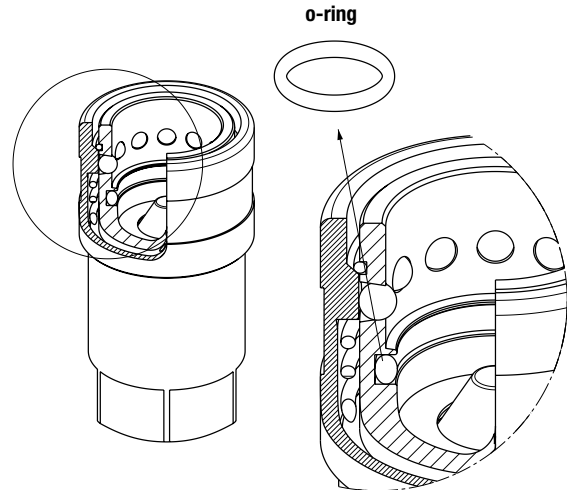

PROTECTIVE CAPS FOR IR-V SERIES

Protective caps are always recommended to protect the couplings from damage, dirt inclusion, and will increase the product life. This is particularly important in agriculture applications where exposure to weather and aggregate materials are common.

The protective caps for IR-V series are manufactured in plastic with connection lanyard (standard color red, other colors available upon request).

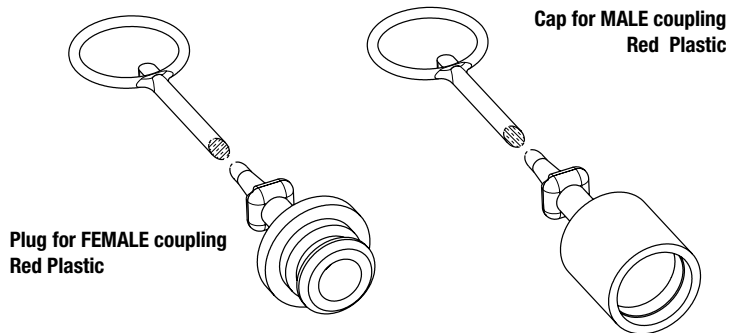

Body Size/Description	Protective Cap		Material/Color
	Plug for Female	Cap for Male	
1/4" IR-V 14	815000000	815000001	Plastic/Red
3/8" IR-V 38	815000002	815000003	Plastic/Red
1/2" IR-V 12	815000004	815000005	Plastic/Red
3/4" IR-V 34	815000006	815000007	Plastic/Red
1" IR-V 100	815000008	815000009	Plastic/Red



IRB SERIES

INTERCHANGE > ISO 7241 B



TECHNICAL FEATURES AND OPTIONS

Interchange ISO 7241 B	Sealing description Nitrile NBR	Connection system Single acting sleeve
Available sizes From 1/8" to 1"	Material/treatment Carbon steel /Cr3	Available threads BSP - NPT - SAE
Operating pressure Up to 350 bar	Locking mechanism Locking Ball system	Flow rate Up to 200 l/min
Temperature (°C) -20° / +100°	Valving style Poppet	Connection under pressure Connection: not allowed Disconnection: not allowed

BENEFITS

- The poppet valve with elastomer seal provides maximum sealing of the couplings when disconnected.
- Shape of internal parts is designed to reduce turbulence and pressure drop.
- Compact slim design.
- Simple to use.

HOW TO USE

- Before to connect, clean the mating surface of the couplings to avoid dirt inclusion in the circuit.
- To connect pull back the sleeve of the female coupling, align the female with the male coupling and push one into the other until both halves are fully connected and release the sleeve.
- To disconnect push back the sleeve of the female coupling, pull out the mating half.

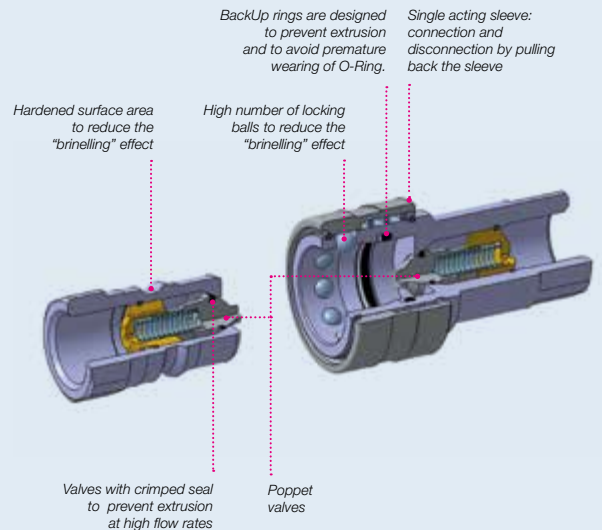
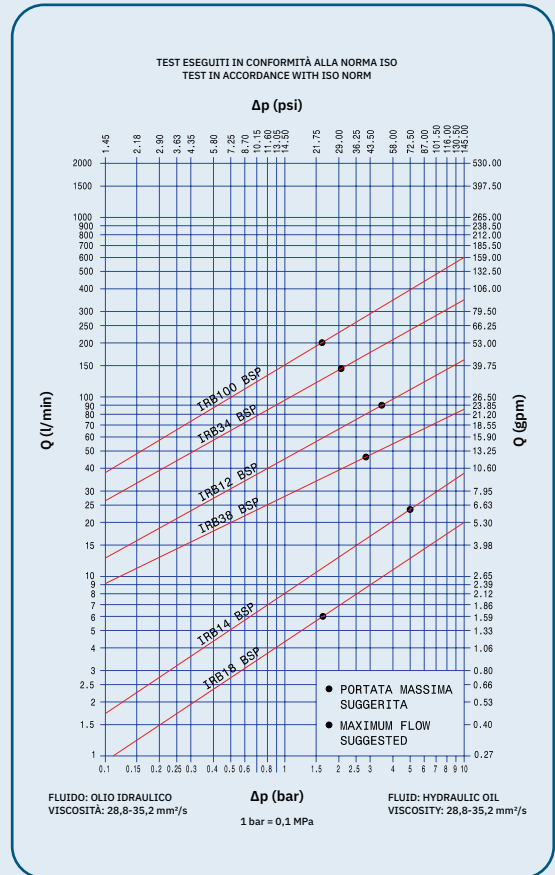

MAIN APPLICATIONS



POPPET



PERFORMANCES

Size		Series/Size	Max. flow suggested		Connect force		Disconnect force		Spillage*
Inch	mm (ISO)		l/min	gpm	N	lbf	N	lbf	ml
1/8	5,0	IRB18	6	1,59	75	16,88	35	7,88	0,18
1/4	6,3	IRB14	24	6,36	50	11,25	35	7,88	0,33
3/8	10,0	IRB38	46	12,19	80	18,00	45	10,13	2,20
1/2	12,5	IRB12	90	23,85	105	23,63	35	7,88	3,00
3/4	20,0	IRB34	148	39,22	125	28,13	40	9,00	9,40
1	25,0	IRB100	200	53,00	130	29,25	45	10,13	14,00

Size	Series/Size	Max. operating pressure						Burst pressure					
		Coupled		Male		Female		Coupled		Male		Female	
Inch		MPa	psi	MPa	psi	MPa	psi	MPa	psi	MPa	psi	MPa	psi
1/8	IRB18	35	5075	35	5075	35	5075	120	17400	120	17400	120	17400
1/4	IRB14	35	5075	35	5075	35	5075	100	14500	100	14500	100	14500
3/8	IRB38	30	4350	30	4350	30	4350	100	14500	100	14500	100	14500
1/2	IRB12	28	4060	28	4060	28	4060	100	14500	100	14500	100	14500
3/4	IRB34	23	3335	23	3335	23	3335	100	14500	100	14500	100	14500
1	IRB100	18	2610	18	2610	18	2610	80	11600	80	11600	80	11600

* Spillage is an indicative value of the fluid loss during disconnection (according to ISO norm test method).

Different possible configurations:

PL version (free flow without valve) available upon request.

SAE thread available upon request.

Temperature range:

Standard seals in NBR (Nitrile): from -20°C to +100°C (from -4 °F to +212 °F).

Upon request seals in VITON®: from -15°C to +180°C (from +5 °F to +356 °F).

Please read carefully Instructions and warnings for proper selection of the products.



WARNING

A defect, a wrong choice or an improper use of products, can cause injury to persons, animals and objects.

Never connect or disconnect with dynamic pressure (e.g. pump on).

Do not use the coupling disconnected with high impulse pressure.

Do not couple-uncouple with flow and/or pressure in the circuit.

Do not couple-uncouple when the temperature inside of the circuit is higher than 80 °C (176 °F).

Check the maximum allowable working pressure of the port in use.

Make sure that the medium used is compatible with seal and material as indicated for each series.

In case of doubt please contact Stucchi Technical Support.

The interchangeability is mentioned under the assumption that the manufacturer of the considered products has not changed any dimension.

It is mandatory to carefully read and closely follow the instructions before selecting or using any Stucchi products.

Always refer to the version uploaded in the Instructions and warning section of stuchigroup.com website for the latest release.

For specific, product-related, instructions, please contact Stucchi technical service.

OVERALL DIMENSIONS

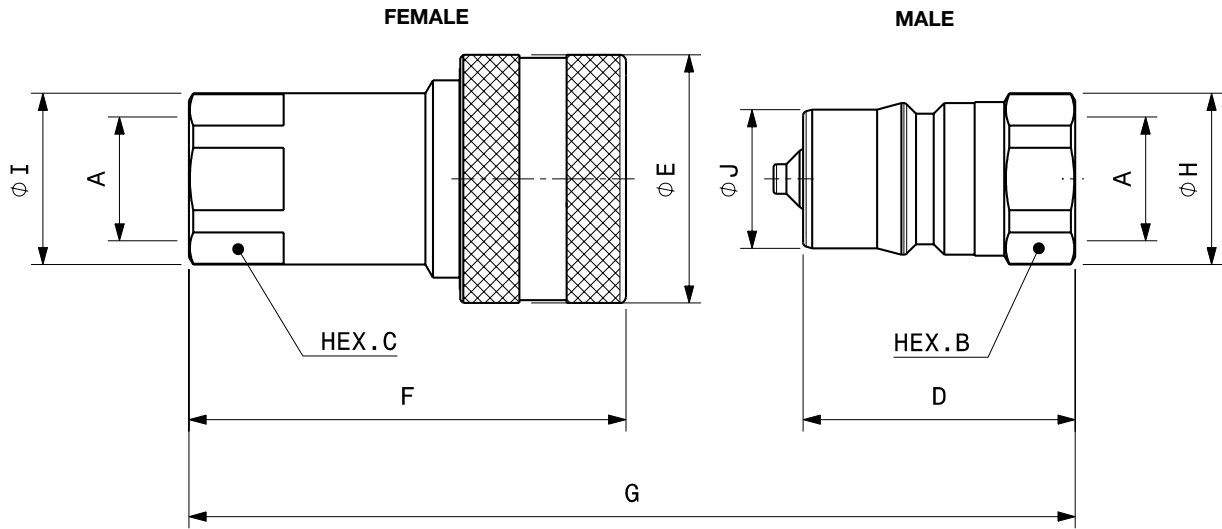

Port description: FEMALE THREAD BSP (ISO 1179-1)

BODY SIZE	Descriptive Code	Item Code	ISO DN	PORT (A)	Overall Length		Length		Hex		Overall Diameter		Body Diameter		Weight						
					mm	inch	mm	inch	mm	inch	mm	inch	mm	inch	Kg	Lbs					
1/8"	F IRB18 BSP	Female 800600000	5,0	1/8"	G	60,5	2,38	F	48,8	1,92	C	14,0	0,55	I	15,8	0,62	E	23,0	0,91	0,07	0,15
	M IRB18 BSP	Male 800600001						D	30,0	1,18	B	14,0	0,55	H	15,8	0,62	J	10,8	0,43	0,02	0,04
1/4"	F IRB14 BSP	Female 800600002	6,3	1/4"	G	70,7	2,78	F	57,0	2,24	C	19,0	0,75	I	21,2	0,83	E	27,0	1,06	0,12	0,26
	M IRB14 BSP	Male 800600003						D	35,0	1,38	B	19,0	0,75	H	20,8	0,82	J	14,2	0,56	0,04	0,08
3/8"	F IRB38 BSP	Female 800600004	10,0	3/8"	G	82,7	3,26	F	66,0	2,60	C	24,0	0,94	I	27,0	1,06	E	34,0	1,34	0,22	0,49
	M IRB38 BSP	Male 800600005						D	41,0	1,61	B	24,0	0,94	H	26,0	1,02	J	19,1	0,75	0,07	0,15
1/2"	F IRB12 BSP	Female 800600006	12,5	1/2"	G	92,6	3,65	F	73,9	2,91	C	27,0	1,06	I	29,0	1,14	E	42,0	1,65	0,32	0,71
	M IRB12 BSP	Male 800600007						D	46,0	1,81	B	27,0	1,06	H	29,0	1,14	J	23,5	0,93	0,10	0,22
3/4"	F IRB34 BSP	Female 800600008	20,0	3/4"	G	111,1	4,37	F	90,1	3,55	C	36,0	1,42	I	38,5	1,52	E	50,0	1,97	0,56	1,24
	M IRB34 BSP	Male 800600009						D	55,0	2,17	B	36,0	1,42	H	38,5	1,52	J	31,4	1,24	0,20	0,45
1"	F IRB100 BSP	Female 800600010	25,0	1"	G	133,2	5,24	F	106,2	4,18	C	41,0	1,61	I	44,8	1,76	E	60,0	2,36	0,86	1,90
	M IRB100 BSP	Male 800600011						D	66,0	2,60	B	41,0	1,61	H	44,8	1,76	J	37,7	1,48	0,33	0,72

Port description: FEMALE THREAD NPT (ANSI B1.20.1)

BODY SIZE	Descriptive Code	Item Code	ISO DN	PORT (A)	Overall Length		Length		Hex		Overall Diameter		Body Diameter		Weight						
					mm	inch	mm	inch	mm	inch	mm	inch	mm	inch	Kg	Lbs					
1/8"	F IRB18 NPT	Female 800601000	5,0	1/8"	G	60,5	2,38	F	48,8	1,92	C	14,0	0,55	I	15,8	0,62	E	23,0	0,91	0,07	0,15
	M IRB18 NPT	Male 800601001						D	30,0	1,18	B	14,0	0,55	H	15,8	0,62	J	10,8	0,43	0,02	0,04
1/4"	F IRB14 NPT	Female 800601002	6,3	1/4"	G	70,7	2,78	F	57,0	2,24	C	19,0	0,75	I	21,2	0,83	E	27,0	1,06	0,12	0,26
	M IRB14 NPT	Male 800601003						D	35,0	1,38	B	19,0	0,75	H	20,8	0,82	J	14,2	0,56	0,04	0,08
3/8"	F IRB38 NPT	Female 800601004	10,0	3/8"	G	82,7	3,26	F	66,0	2,60	C	24,0	0,94	I	27,0	1,06	E	34,0	1,34	0,22	0,49
	M IRB38 NPT	Male 800601005						D	41,0	1,61	B	24,0	0,94	H	26,0	1,02	J	19,1	0,75	0,07	0,15
1/2"	F IRB12 NPT	Female 800601006	12,5	1/2"	G	92,6	3,65	F	73,9	2,91	C	27,0	1,06	I	29,0	1,14	E	42,0	1,65	0,32	0,71
	M IRB12 NPT	Male 800601007						D	46,0	1,81	B	27,0	1,06	H	29,0	1,14	J	23,5	0,93	0,11	0,23
3/4"	F IRB34 NPT	Female 800601008	20,0	3/4"	G	111,1	4,37	F	90,1	3,55	C	36,0	1,42	I	38,5	1,52	E	50,0	1,97	0,56	1,24
	M IRB34 NPT	Male 800601009						D	55,0	2,17	B	36,0	1,42	H	38,5	1,52	J	31,4	1,24	0,21	0,46
1"	F IRB100 NPT	Female 800601010	25,0	1"	G	133,2	5,24	F	106,2	4,18	C	41,0	1,61	I	44,8	1,76	E	60,0	2,36	0,88	1,94
	M IRB100 NPT	Male 800601011						D	66,0	2,60	B	41,0	1,61	H	44,8	1,76	J	37,7	1,48	0,34	0,75



SPARE KIT SEAL FOR FEMALE

Repair kit / OR+BK		
Body Size	Description	Part Number
1/8"	F IRB18	815700202
1/4"	F IRB14	815700204
3/8"	F IRB38	815700206
1/2"	F IRB12	815700208
3/4"	F IRB34	815700210
1"	F IRB100	815700212

O-Ring in Nitrile
BackUp in Teflon®

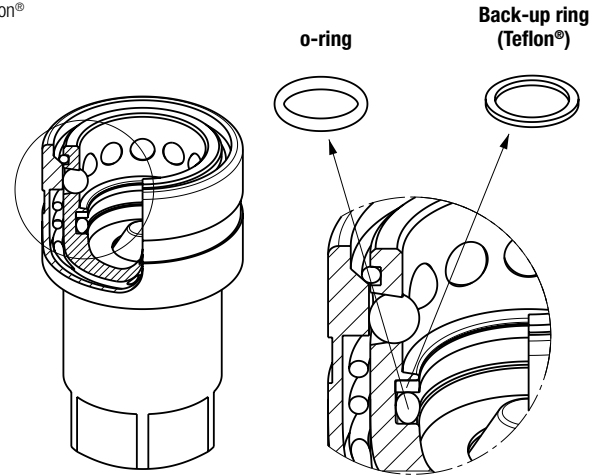

PROTECTIVE CAPS FOR IRB SERIES

Protective caps are always recommended to protect the couplings from damage, dirt inclusion, and will increase the product life. The protective caps for IRB series are manufactured in plastic with connection lanyard (standard color red, other colors available upon request).

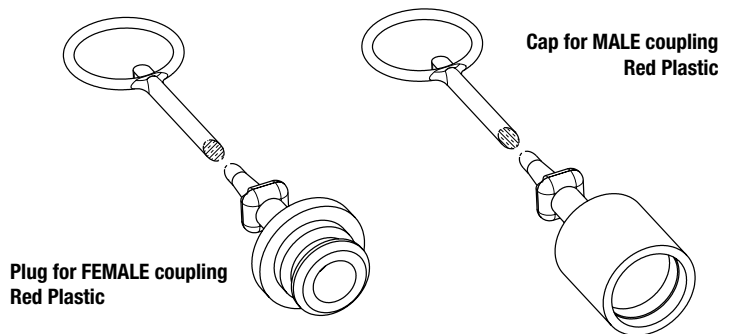

Protective Cap				
Body Size/Description	Part Number		Material/Color	
	Plug for Female	Cap for Male		
1/4" IRB14	815000032	815000033	Plastic/Red	
3/8" IRB38	815000034	815000035	Plastic/Red	
1/2" IRB12	815000036	815000037	Plastic/Red	
3/4" IRB34	815000038	815000039	Plastic/Red	
1" IRB100	815000040	815000041	Plastic/Red	

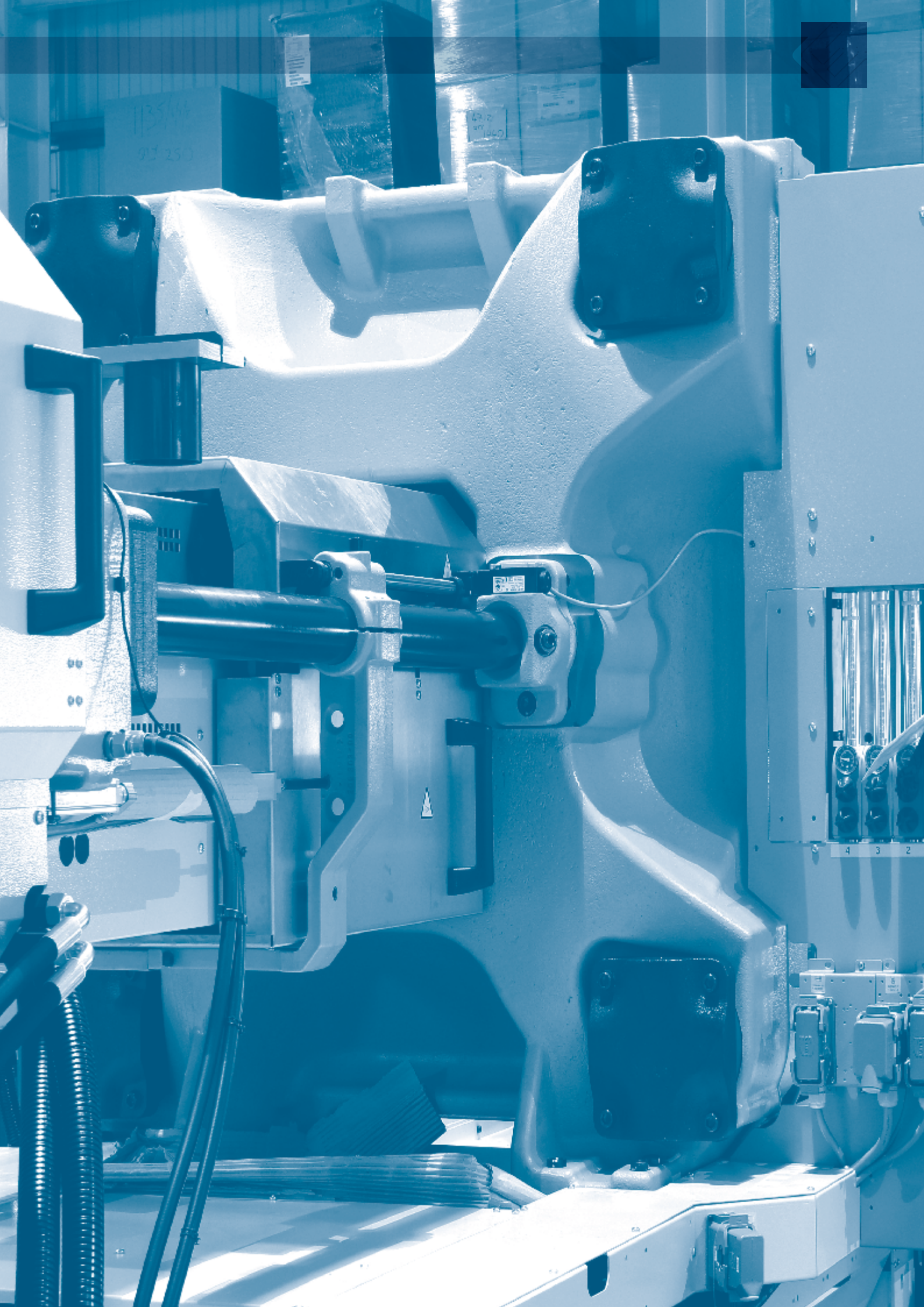

IRBOSERIES













INTERCHANGE > ISO 7241 B



Stucchi®



TECHNICAL FEATURES AND OPTIONS

 Interchange ISO 7241 B	 Sealing description FKM (VITON®)	 Connection system Single acting sleeve
 Available sizes From 1/8" to 1"	 Material Brass	 Available threads BSP - NPT
 Operating pressure Up to 200 bar	 Locking mechanism Locking Ball system	 Flow rate Up to 200 l/min
 Temperature (°C) -15° / + 180°	 Valving style Poppet	 Connection under pressure Connection: not allowed Disconnection: not allowed

BENEFITS

- The poppet valve with elastomer seal provides maximum sealing of the couplings when disconnected.
- Shape of internal parts is designed to reduce turbulence and pressure drop.
- Superior corrosion resistance compared to Chrome 3.
- Compact slim design.
- Simple to use.

HOW TO USE

- Before to connect, clean the mating surface of the couplings to avoid dirt inclusion in the circuit.
- To connect pull back the sleeve of the female coupling, align the female with the male coupling and push one into the other until both halves are fully connected and release the sleeve.
- To disconnect push back the sleeve of the female coupling, pull out the mating half.

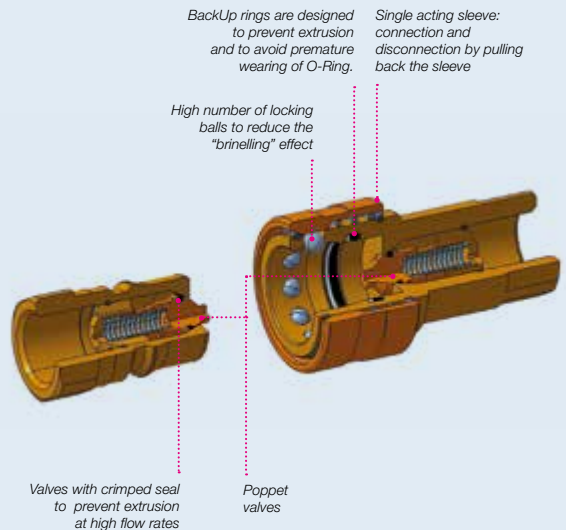
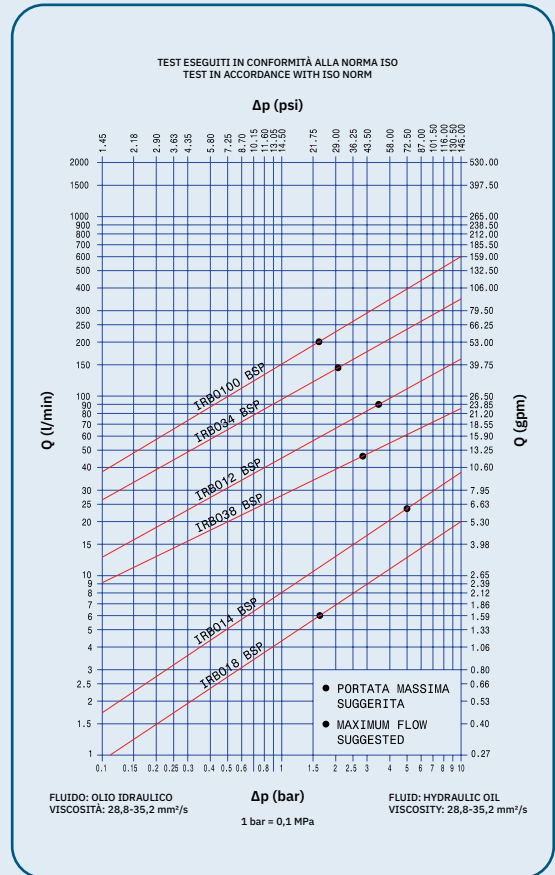

MAIN APPLICATIONS



POPPET

PERFORMANCES

Size		Series/Size	Max. flow suggested		Connect force		Disconnect force		Spillage*
Inch	mm (ISO)		l/min	gpm	N	lbf	N	lbf	ml
1/8	5,0	IRB018	6	1,59	75	16,88	35	7,88	0,18
1/4	6,3	IRB014	24	6,36	60	13,50	30	6,75	0,33
3/8	10,0	IRB038	46	12,19	95	21,38	35	7,88	2,20
1/2	12,5	IRB012	90	23,85	95	21,38	35	7,88	3,00
3/4	20,0	IRB034	148	39,22	125	28,13	40	9,00	9,40
1	25,0	IRB0100	200	53,00	140	31,50	40	9,00	14,00

Size	Series/Size	Max. operating pressure						Burst pressure					
		Coupled		Male		Female		Coupled		Male		Female	
Inch		MPa	psi	MPa	psi	MPa	psi	MPa	psi	MPa	psi	MPa	psi
1/8	IRB018	20	2900	20	2900	20	2900	100	14500	100	14500	100	14500
1/4	IRB014	20	2900	20	2900	20	2900	100	14500	100	14500	100	14500
3/8	IRB038	16	2320	16	2320	16	2320	80	11600	70	10150	80	11600
1/2	IRB012	16	2320	16	2320	16	2320	80	11600	70	10150	80	11600
3/4	IRB034	12,5	1813	12,5	1813	12,5	1813	60	8700	45	6525	60	8700
1	IRB0100	10	1450	10	1450	10	1450	40	5800	40	5800	40	5800

* Spillage is an indicative value of the fluid loss during disconnection (according to ISO norm test method).

Different possible configurations

PL version (free flow without valve) available upon request.

SAE thread available upon request.

Temperature range:

Standard seals in VITON®: from -15°C to +180°C (from +5 °F to +356 °F).

Upon request seals in NBR (Nitrile) from -20 °C to +100 °C (from -4 °F to +212 °F).

Upon request seals in EPDM (Ethylene Propylene): from -40 °C to +150 °C

(from -40 °F to +302 °F).

Please read carefully Instructions and warnings for proper selection of the products.

! WARNING

A defect, a wrong choice or an improper use of products, can cause injury to persons, animals and objects.

Never connect or disconnect with dynamic pressure (e.g. pump on).

Do not use the coupling disconnected with high impulse pressure.

Do not couple-uncouple with flow and/or pressure in the circuit.

Do not couple-uncouple when the temperature inside of the circuit is higher than 80 °C (176 °F).

Check the maximum allowable working pressure of the port in use.

Make sure that the medium used is compatible with seal and material as indicated for each series.

In case of doubt please contact Stucchi Technical Support.

The interchangeability is mentioned under the assumption that the manufacturer of the considered products has not changed any dimension.

It is mandatory to carefully read and closely follow the instructions before selecting or using any Stucchi products.

Always refer to the version uploaded in the Instructions and warning section of stucchigroup.com website for the latest release.

For specific, product-related, instructions, please contact Stucchi technical service.

OVERALL DIMENSIONS

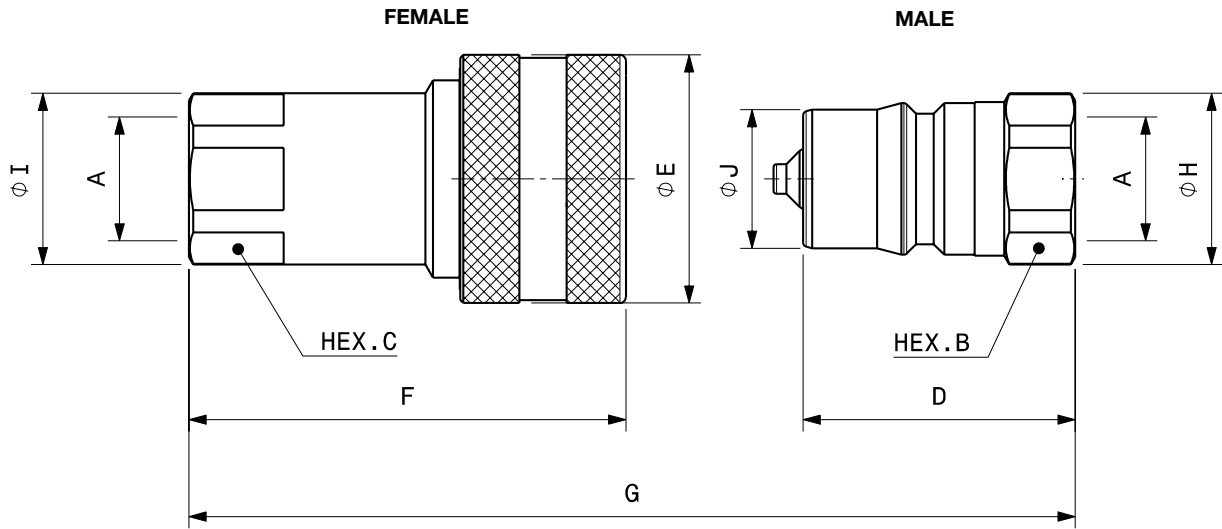

Port description: FEMALE THREAD BSPP (ISO 1179-1)

BODY SIZE	Descriptive Code	Item Code	ISO DN	PORT (A)	Overall Length		Length		Hex		Overall Diameter		Body Diameter		Weight						
					mm	inch	mm	inch	mm	inch	mm	inch	mm	inch	Kg	Lbs					
1/8"	F IRBO18 BSP	Female 804500100	5,0	1/8"	G	60,5	2,38	F	48,8	1,92	C	14,0	0,55	I	15,8	0,62	E	23,0	0,91	0,07	0,15
	M IRBO18 BSP	Male 804500101						D	30,0	1,18	B	14,0	0,55	H	15,8	0,62	J	10,8	0,43	0,02	0,04
1/4"	F IRBO14 BSP	Female 804500102	6,3	1/4"	G	70,7	2,78	F	57,0	2,24	C	19,0	0,75	I	21,2	0,83	E	27,0	1,06	0,13	0,29
	M IRBO14 BSP	Male 804500103						D	35,0	1,38	B	19,0	0,75	H	20,8	0,82	J	14,2	0,56	0,04	0,08
3/8"	F IRBO38 BSP	Female 804500104	10,0	3/8"	G	82,7	3,26	F	66,0	2,60	C	24,0	0,94	I	27,0	1,06	E	34,0	1,34	0,24	0,52
	M IRBO38 BSP	Male 804500105						D	41,0	1,61	B	24,0	0,94	H	26,0	1,02	J	19,1	0,75	0,07	0,16
1/2"	F IRBO12 BSP	Female 804500106	12,5	1/2"	G	92,6	3,65	F	73,9	2,91	C	27,0	1,06	I	29,0	1,14	E	42,0	1,65	0,34	0,76
	M IRBO12 BSP	Male 804500107						D	46,0	1,81	B	27,0	1,06	H	29,0	1,14	J	23,5	0,93	0,11	0,24
3/4"	F IRBO34 BSP	Female 804500108	20,0	3/4"	G	111,1	4,37	F	90,1	3,55	C	36,0	1,42	I	38,5	1,52	E	50,0	1,97	0,61	1,33
	M IRBO34 BSP	Male 804500109						D	55,0	2,17	B	36,0	1,42	H	38,5	1,52	J	31,4	1,24	0,22	0,48
1"	F IRBO100 BSP	Female 804500110	25,0	1"	G	133,2	5,24	F	106,2	4,18	C	41,0	1,61	I	44,8	1,76	E	60,0	2,36	0,93	2,04
	M IRBO100 BSP	Male 804500111						D	66,0	2,60	B	41,0	1,61	H	44,8	1,76	J	37,7	1,48	0,35	0,78

Port description: FEMALE THREAD NPT (ANSI B.1.20.1)

BODY SIZE	Descriptive Code	Item Code	ISO DN	PORT (A)	Overall Length		Length		Hex		Overall Diameter		Body Diameter		Weight						
					mm	inch	mm	inch	mm	inch	mm	inch	mm	inch	Kg	Lbs					
1/8"	F IRBO18 NPT	Female 804501100	5,0	1/8"	G	60,5	2,38	F	48,8	1,92	C	14,0	0,55	I	15,8	0,62	E	23,0	0,91	0,08	0,17
	M IRBO18 NPT	Male 804501101						D	30,0	1,18	B	14,0	0,55	H	15,8	0,62	J	10,8	0,43	0,02	0,04
1/4"	F IRBO14 NPT	Female 804501102	6,3	1/4"	G	70,7	2,78	F	57,0	2,24	C	19,0	0,75	I	21,2	0,83	E	27,0	1,06	0,13	0,29
	M IRBO14 NPT	Male 804501103						D	35,0	1,38	B	19,0	0,75	H	20,8	0,82	J	14,2	0,56	0,04	0,09
3/8"	F IRBO38 NPT	Female 804501104	10,0	3/8"	G	82,7	3,26	F	66,0	2,60	C	24,0	0,94	I	27,0	1,06	E	34,0	1,34	0,23	0,51
	M IRBO38 NPT	Male 804501105						D	41,0	1,61	B	24,0	0,94	H	26,0	1,02	J	19,1	0,75	0,08	0,17
1/2"	F IRBO12 NPT	Female 804501106	12,5	1/2"	G	92,6	3,65	F	73,9	2,91	C	27,0	1,06	I	29,0	1,14	E	42,0	1,65	0,35	0,76
	M IRBO12 NPT	Male 804501107						D	46,0	1,81	B	27,0	1,06	H	29,0	1,14	J	23,5	0,93	0,12	0,25
3/4"	F IRBO34 NPT	Female 804501108	20,0	3/4"	G	111,1	4,37	F	90,1	3,55	C	36,0	1,42	I	38,5	1,52	E	50,0	1,97	0,61	1,33
	M IRBO34 NPT	Male 804501109						D	55,0	2,17	B	36,0	1,42	H	38,5	1,52	J	31,4	1,24	0,22	0,49
1"	F IRBO100 NPT	Female 804501110	25,0	1"	G	133,2	5,24	F	106,2	4,18	C	41,0	1,61	I	44,8	1,76	E	60,0	2,36	0,94	2,07
	M IRBO100 NPT	Male 804501111						D	66,0	2,60	B	41,0	1,61	H	44,8	1,76	J	37,7	1,48	0,36	0,79



SPARE KIT SEAL FOR FEMALE

Repair kit / OR+BK		
Body Size	Description	Part Number
1/8"	F IRB018	815700214
1/4"	F IRB014	815700216
3/8"	F IRB038	815700218
1/2"	F IRB012	815700220
3/4"	F IRB034	815700222
1"	F IRB0100	815700224

O-Ring in VITON®
BackUp in Teflon®

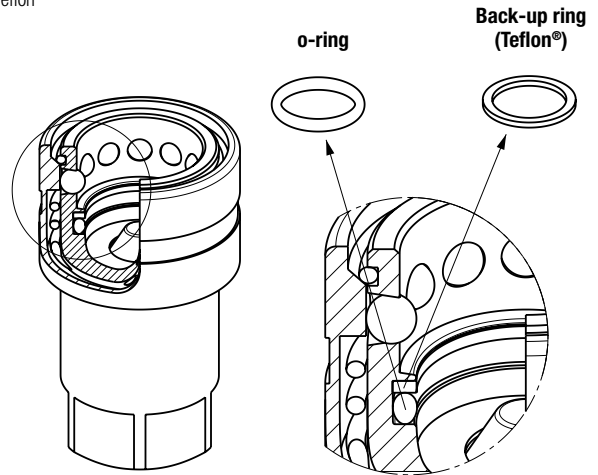

PROTECTIVE CAPS FOR IRBO SERIES

Protective caps are always recommended to protect the couplings from damage, dirt inclusion, and will increase the product life. The protective caps for IRBO series are manufactured in plastic with connection lanyard (standard color red, other colors available upon request).

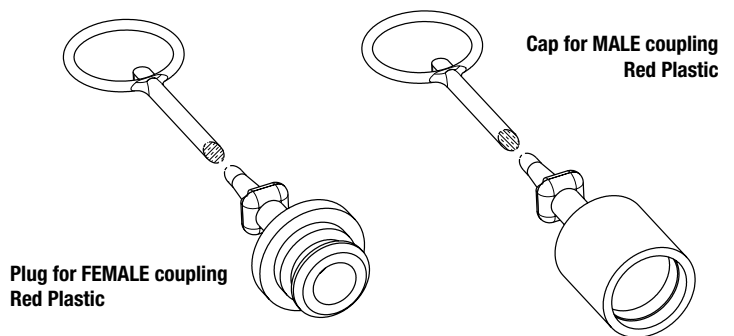

Body Size/Description		Protective Cap		Material/Color
		Plug for Female	Cap for Male	
1/4"	IRB014	815000032	815000033	Plastic/Red
3/8"	IRB038	815000034	815000035	Plastic/Red
1/2"	IRB012	815000036	815000037	Plastic/Red
3/4"	IRB034	815000038	815000039	Plastic/Red
1"	IRB0100	815000040	815000041	Plastic/Red



IRBX SERIES

INTERCHANGE > ISO 7241 B



TECHNICAL FEATURES AND OPTIONS

Interchange ISO 7241 B	Sealing description FKM (VITON®)	Connection system Single acting sleeve
Available sizes From 1/8" to 1"	Material Stainless steel (AISI 316L) Retainer in brass	Available threads BSP - NPT
Operating pressure Up to 250 bar	Locking mechanism Locking Ball system	Flow rate Up to 200 l/min
Temperature (°C) -15° / +180°	Valving style Poppet	Connection under pressure Connection: not allowed Disconnection: not allowed

BENEFITS

- The poppet valve with elastomer seal provides maximum sealing of the couplings when disconnected.
- Shape of internal parts is designed to reduce turbulence and pressure drop.
- Good corrosion resistance.
- Compact slim design.
- Simple to use.

HOW TO USE

- Before to connect, clean the mating surface of the couplings to avoid dirt inclusion in the circuit.
- To connect pull back the sleeve of the female coupling, align the female with the male coupling and push one into the other until both halves are fully connected and release the sleeve.
- To disconnect push back the sleeve of the female coupling, pull out the mating half.

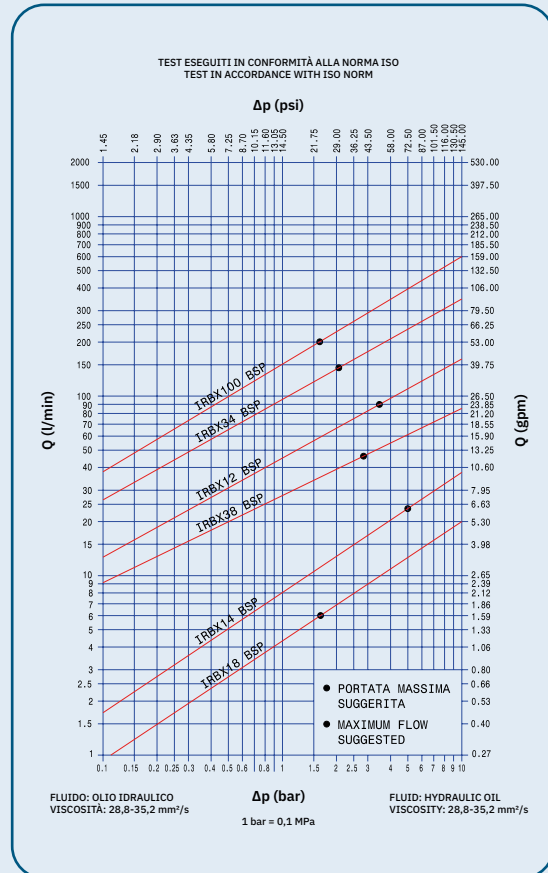

High number of locking balls to reduce the "brinelling" effect
 BackUp rings are designed to prevent extrusion and to avoid premature wearing of O-Ring
 Single acting sleeve: connection and disconnection by pulling back the sleeve

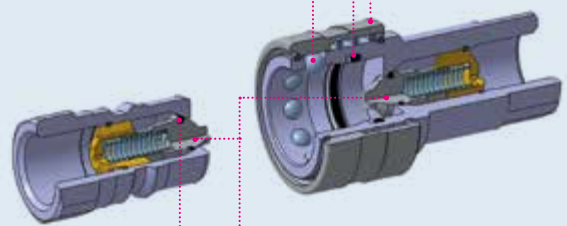

Valves with crimped seal to prevent extrusion at high flow rates

Poppet valves

MAIN APPLICATIONS



POPPET



PERFORMANCES

Size		Series/Size	Max. flow suggested		Connect force		Disconnect force		Spillage*
Inch	mm (ISO)		l/min	gpm	N	lbf	N	lbf	ml
1/8	5,0	IRBX18	6	1,59	75	16,88	35	7,88	0,18
1/4	6,3	IRBX14	24	6,36	60	13,50	30	6,75	0,33
3/8	10,0	IRBX38	46	12,19	90	20,25	35	7,88	2,20
1/2	12,5	IRBX12	90	23,85	125	28,13	45	10,13	3,00
3/4	20,0	IRBX34	148	39,22	135	30,38	55	12,38	9,40
1	25,0	IRBX100	200	53,00	140	31,50	40	9,00	14,00

Size	Series/Size	Max. operating pressure						Burst pressure					
		Coupled		Male		Female		Coupled		Male		Female	
Inch		MPa	psi	MPa	psi	MPa	psi	MPa	psi	MPa	psi	MPa	psi
1/8	IRBX18	25	3625	25	3625	25	3625	140	20300	140	20300	140	20300
1/4	IRBX14	25	3625	25	3625	25	3625	140	20300	140	20300	140	20300
3/8	IRBX38	20	2900	20	2900	20	2900	100	14500	100	14500	100	14500
1/2	IRBX12	20	2900	20	2900	20	2900	100	14500	100	14500	100	14500
3/4	IRBX34	16	2320	16	2320	16	2320	80	11600	80	11600	80	11600
1	IRBX100	12,5	1813	12,5	1813	12,5	1813	60	8700	60	8700	60	8700

* Spillage is an indicative value of the fluid loss during disconnection (according to ISO norm test method).

Different possible configurations:

PL version (free flow without valve) available upon request.
 IRBX-X internal retainer in stainless steel available upon request.
 SAE thread available upon request.

Temperature range:

Standard seals in VITON®: from -15°C to +180°C (from +5 °F to +356 °F).
 Please read carefully Instructions and warnings for proper selection of the products.
 Upon request seals in NBR (Nitrile): from -20 °C to +100 °C (from -4 °F to +212 °F).
 Upon request seals in EPDM (Ethylene Propylene): from -40 °C to +150 °C (from -40 °F to +302 °F).

Material:

- Construction: Stainless steel AISI 316L
- Springs: AISI 302
- Locking ball: AISI 316



WARNING

A defect, a wrong choice or an improper use of products, can cause injury to persons, animals and objects.
 Never connect or disconnect with dynamic pressure (e.g. pump on).
 Do not use the coupling disconnected with high impulse pressure.
 Do not couple-uncouple with flow and/or pressure in the circuit.
 Do not couple-uncouple when the temperature inside of the circuit is higher than 80 °C (176 °F).
 Check the maximum allowable working pressure of the port in use.
 Make sure that the medium used is compatible with seal and material as indicated for each series.
 In case of doubt please contact Stucchi Technical Support.
 The interchangeability is mentioned under the assumption that the manufacturer of the considered products has not changed any dimension.
It is mandatory to carefully read and closely follow the instructions before selecting or using any Stucchi products.
Always refer to the version uploaded in the Instructions and warning section of stucchigroup.com website for the latest release.
For specific, product-related, instructions, please contact Stucchi technical service.

OVERALL DIMENSIONS

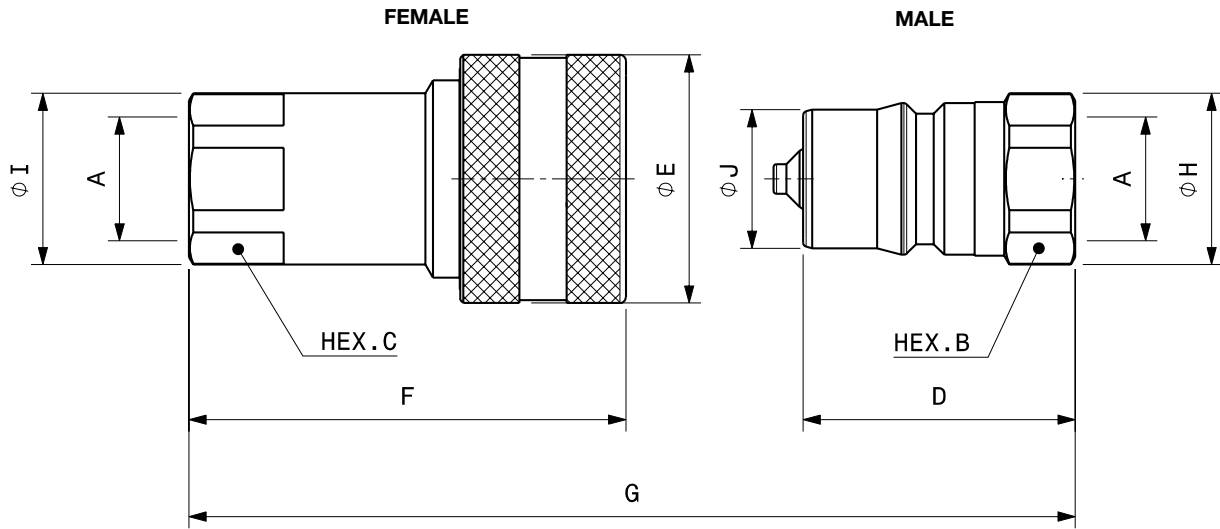

Port description: FEMALE THREAD BSPP (ISO 1179-1)

BODY SIZE	Descriptive Code	Item Code	ISO DN	PORT (A)	Overall Length		Length		Hex		Overall Diameter		Body Diameter		Weight						
					mm	inch	mm	inch	mm	inch	mm	inch	mm	inch	Kg	Lbs					
1/8"	F IRBX18 BSP	Female 804600100	5,0	1/8"	G	60,5	2,38	F	48,8	1,92	C	14,0	0,55	I	15,8	0,62	E	23,0	0,91	0,07	0,15
	M IRBX18 BSP	Male 804600101						D	30,0	1,18	B	14,0	0,55	H	15,8	0,62	J	10,8	0,43	0,02	0,04
1/4"	F IRBX14 BSP	Female 804600102	6,3	1/4"	G	70,7	2,78	F	57,0	2,24	C	19,0	0,75	I	21,2	0,83	E	27,0	1,06	0,12	0,27
	M IRBX14 BSP	Male 804600103						D	35,0	1,38	B	19,0	0,75	H	20,8	0,82	J	14,2	0,56	0,04	0,08
3/8"	F IRBX38 BSP	Female 804600104	10,0	3/8"	G	82,7	3,26	F	66,0	2,60	C	24,0	0,94	I	27,0	1,06	E	34,0	1,34	0,23	0,50
	M IRBX38 BSP	Male 804600105						D	41,0	1,61	B	24,0	0,94	H	26,0	1,02	J	19,1	0,75	0,07	0,15
1/2"	F IRBX12 BSP	Female 804600106	12,5	1/2"	G	92,6	3,65	F	73,9	2,91	C	27,0	1,06	I	29,0	1,14	E	42,0	1,65	0,33	0,72
	M IRBX12 BSP	Male 804600107						D	46,0	1,81	B	27,0	1,06	H	29,0	1,14	J	23,5	0,93	0,10	0,23
3/4"	F IRBX34 BSP	Female 804600108	20,0	3/4"	G	111,1	4,37	F	90,1	3,55	C	36,0	1,42	I	38,5	1,52	E	50,0	1,97	0,58	1,27
	M IRBX34 BSP	Male 804600109						D	55,0	2,17	B	36,0	1,42	H	38,5	1,52	J	31,4	1,24	0,21	0,45
1"	F IRBX100 BSP	Female 804600110	25,0	1"	G	133,2	5,24	F	106,2	4,18	C	41,0	1,61	I	44,8	1,76	E	60,0	2,36	0,88	1,94
	M IRBX100 BSP	Male 804600111						D	66,0	2,60	B	41,0	1,61	H	44,8	1,76	J	37,7	1,48	0,34	0,74

Port description: FEMALE THREAD NPT (ANSI B.1.20.1)

BODY SIZE	Descriptive Code	Item Code	ISO DN	PORT (A)	Overall Length		Length		Hex		Overall Diameter		Body Diameter		Weight						
					mm	inch	mm	inch	mm	inch	mm	inch	mm	inch	Kg	Lbs					
1/8"	F IRBX18 NPT	Female 804601100	5,0	1/8"	G	60,5	2,38	F	48,8	1,92	C	14,0	0,55	I	15,8	0,62	E	23,0	0,91	0,07	0,15
	M IRBX18 NPT	Male 804601101						D	30,0	1,18	B	14,0	0,55	H	15,8	0,62	J	10,8	0,43	0,02	0,04
1/4"	F IRBX14 NPT	Female 804601102	6,3	1/4"	G	70,7	2,78	F	57,0	2,24	C	19,0	0,75	I	21,2	0,83	E	27,0	1,06	0,12	0,27
	M IRBX14 NPT	Male 804601103						D	35,0	1,38	B	19,0	0,75	H	20,8	0,82	J	14,2	0,56	0,04	0,08
3/8"	F IRBX38 NPT	Female 804601104	10,0	3/8"	G	82,7	3,26	F	66,0	2,60	C	24,0	0,94	I	27,0	1,06	E	34,0	1,34	0,23	0,50
	M IRBX38 NPT	Male 804601105						D	41,0	1,61	B	24,0	0,94	H	26,0	1,02	J	19,1	0,75	0,07	0,15
1/2"	F IRBX12 NPT	Female 804601106	12,5	1/2"	G	92,6	3,65	F	73,9	2,91	C	27,0	1,06	I	29,0	1,14	E	42,0	1,65	0,33	0,72
	M IRBX12 NPT	Male 804601107						D	46,0	1,81	B	27,0	1,06	H	29,0	1,14	J	23,5	0,93	0,11	0,24
3/4"	F IRBX34 NPT	Female 804601108	20,0	3/4"	G	111,1	4,37	F	90,1	3,55	C	36,0	1,42	I	38,5	1,52	E	50,0	1,97	0,58	1,28
	M IRBX34 NPT	Male 804601109						D	55,0	2,17	B	36,0	1,42	H	38,5	1,52	J	31,4	1,24	0,21	0,46
1"	F IRBX100 NPT	Female 804601110	25,0	1"	G	133,2	5,24	F	106,2	4,18	C	41,0	1,61	I	44,8	1,76	E	60,0	2,36	0,89	1,96
	M IRBX100 NPT	Male 804601111						D	66,0	2,60	B	41,0	1,61	H	44,8	1,76	J	37,7	1,48	0,34	0,74

POPPET



SPARE KIT SEAL FOR FEMALE

Repair kit / OR+BK		
Body Size	Description	Part Number
1/8"	F IRBX18	815700214
1/4"	F IRBX14	815700216
3/8"	F IRBX38	815700218
1/2"	F IRBX12	815700220
3/4"	F IRBX34	815700222
1"	F IRBX100	815700224

O-Ring in VITON®
BackUp in Teflon®

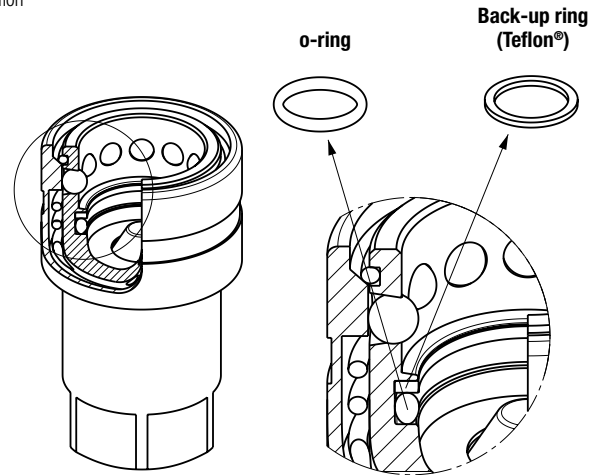

PROTECTIVE CAPS FOR IRBX SERIES

Protective caps are always recommended to protect the couplings from damage, dirt inclusion, and will increase the product life. The protective caps for IRBX series are manufactured in plastic with connection lanyard (standard color red, other colors available upon request).

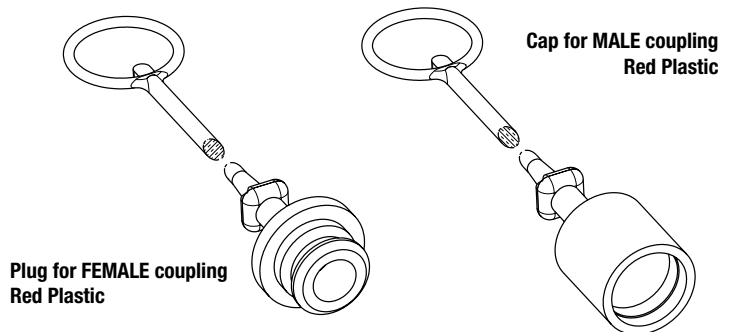

Body Size/Description		Protective Cap		Material/Color
		Plug for Female	Cap for Male	
1/4"	IRBX14	815000032	815000033	Plastic/Red
3/8"	IRBX38	815000034	815000035	Plastic/Red
1/2"	IRBX12	815000036	815000037	Plastic/Red
3/4"	IRBX34	815000038	815000039	Plastic/Red
1"	IRBX100	815000040	815000041	Plastic/Red



IRCSERIES

INTERCHANGE > with similar product (Nordic interface)



Stucchi®



TECHNICAL FEATURES AND OPTIONS

Interchange With similar product (Nordic interface)	Sealing description Nitrile NBR	Connection system Single acting sleeve
Available sizes From 1/4" to 1"	Material/treatment Carbon steel ZnNi	Available threads BSP - NPT - SAE
Operating pressure Up to 450 bar	Locking mechanism Ball locking + safety sleeve	Flow rate Up to 378 l/min
Temperature (°C) -20° / +100°	Valving style Poppet	Connection under pressure Only PC version Connection: one side Disconnection: not allowed

BENEFITS

- Connection under residual pressure is allowed in the male or in the female (PC version). Please notice that the counterpart side should be drained and should use a standard poppet half.
- The poppet valve with elastomer seal provides maximum sealing of the couplings once disconnected.
- O-Ring + BackUp ring for optimum protection sealing.
- The Zinc Nickel plating ensures high resistance to corrosion and it is ideal for hydraulic equipment applications where an improved corrosion resistance is necessary.
- Additional O-Ring for extra sealing capacity and to contain spray effect to avoid soil contamination.
- High durability.
- Reference products for tough applications, typically used in Nordic countries.
- Safety sleeve to prevent accidental disconnection.
- Shape of internal parts is optimized to reduce turbulence and pressure drop.
- High resistance to pressure impulses.
- Compact design.
- Simple to use.

HOW TO USE

- Before to connect, clean the mating surface of the couplings to avoid dirt inclusion in the circuit.
- To connect: pull back the sleeve of the female coupling, align the female with the male coupling and push one into the other until both halves are fully connected and release the sleeve.
- To avoid accidental disconnection rotate safety sleeve.
- To disconnect: unlock the safety sleeve and pull back the sleeve of the female coupling, pull out the mating half.

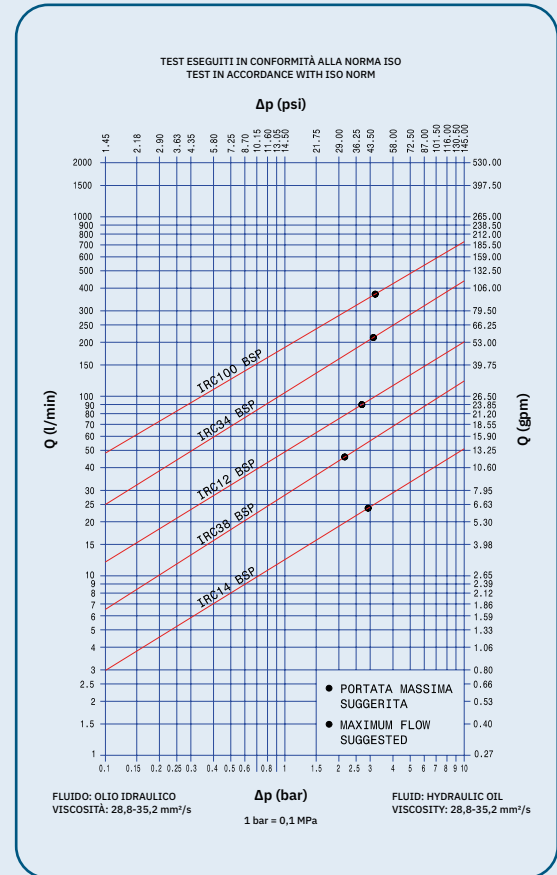

Hardened surface area to reduce the "brinelling" effect

High number of locking balls to reduce the "brinelling" effect

Safety sleeve zinc plated to prevent accidental disconnection

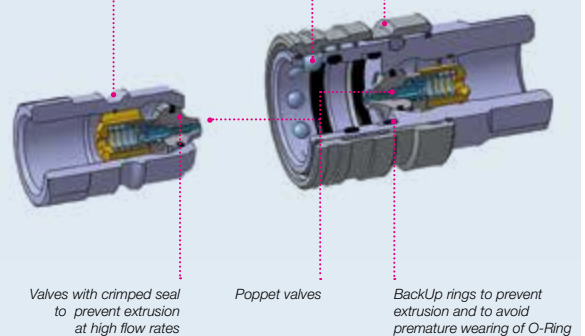

This image represents PC version (release pressure device system)

MAIN APPLICATIONS

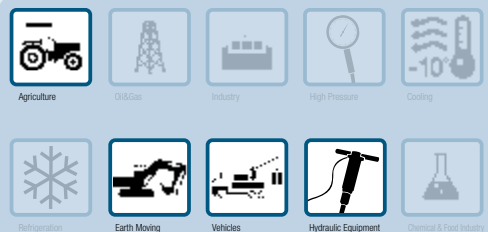

POPPET

PERFORMANCES

Size		Series/Size	Max. flow suggested		Connect force		Disconnect force		Spillage*
Inch	mm		l/min	gpm	N	lbf	N	lbf	ml
1/4	6.3	IRC14	24	6,36	60	13,49	30	6,74	1,1
3/8	10	IRC38	46	12,19	90	20,23	35	7,87	2,5
1/2	12,5	IRC12	90	23,85	120	26,98	35	7,87	3,5
3/4	20	IRC34	212	56,18	170	38,22	45	10,12	15
1	25	IRC100**	378	100,17	210	47,21	45	10,12	18

Size	Series/Size	Max. operating pressure						Burst pressure					
		Coupled		Male		Female		Coupled		Male		Female	
Inch	Steel	MPa	psi	MPa	psi	MPa	psi	MPa	psi	MPa	psi	MPa	psi
1/4	IRC14	45	6525	30	4350	30	4350	180	26100	120	17400	120	17400
3/8	IRC38	35	5075	28	4060	28	4060	130	18850	110	15950	110	15950
1/2	IRC12	33	4785	25	3625	25	3625	110	15950	100	14500	100	14500
3/4	IRC34	33	4785	25	3625	25	3625	100	14500	80	11600	80	11600
1	IRC100**	33	4785	25	3625	25	3625	100	14500	100	14500	100	14500

* Spillage is an indicative value of the fluid loss during disconnection (according to ISO norm test method).

** Specific dimensions of Stucchi IRC series are certified with Lloyd Type Approval in accordance with API 16D at specific rating pressure of 207 bar/3000 PSI. For complete technical information please contact Stucchi Technical Support.

Different possible configurations:

PC version, connectable under residual pressure.

PL version, free flow.

SAE thread available upon request.

For complete technical information please contact Stucchi Technical Support.

Temperature range:

Seals in NBR (Nitrile): from -20 °C to +100 °C (from -4 °F to +212 °F).

Upon request seals in VITON®: from -15°C to +180°C (from +5 °F to +356 °F).

Please read carefully Instructions and warnings for proper selection of the products.

Tests performed:

The couplings have been tested according to ISO norm.

The couplings have been tested at max. operating pressure for 200.000 impulses in coupled position and 100.000 impulses in uncoupled position.

PC version

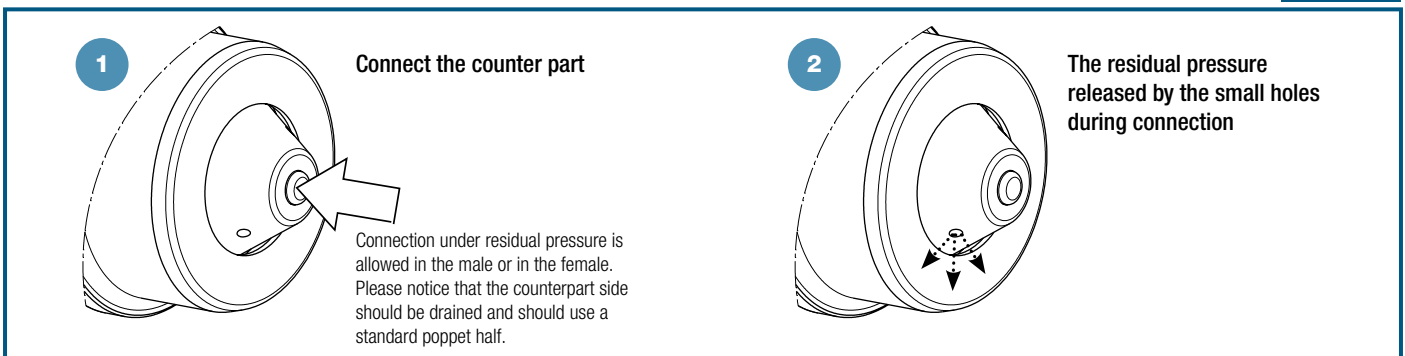

! WARNING

A defect, a wrong choice or an improper use of products, can cause injury to persons, animals and objects.

Connect under pressure products (PC version) are suitable to be connected under residual (static) pressure.

Never connect or disconnect with dynamic pressure (e.g. pump on).

Do not couple-uncouple with flow and pressure in the circuit (except PC version).

Do not couple-uncouple when the temperature inside of the circuit is higher than 80 °C (176 °F).

Do not use the coupling disconnected with high impulse pressure.

Check the maximum allowable working pressure of the port in use.

Make sure that the medium used is compatible with seal and material as indicated for each series.

In case of doubt please contact Stucchi Technical Support.

The interchangeability is mentioned under the assumption that the manufacturer of the considered products has not changed any dimension.

It is mandatory to carefully read and closely follow the instructions before selecting or using any Stucchi products.

Always refer to the version uploaded in the Instructions and warning section of stucchigroup.com website for the latest release.

For specific, product-related, instructions, please contact Stucchi technical service.

OVERALL DIMENSIONS

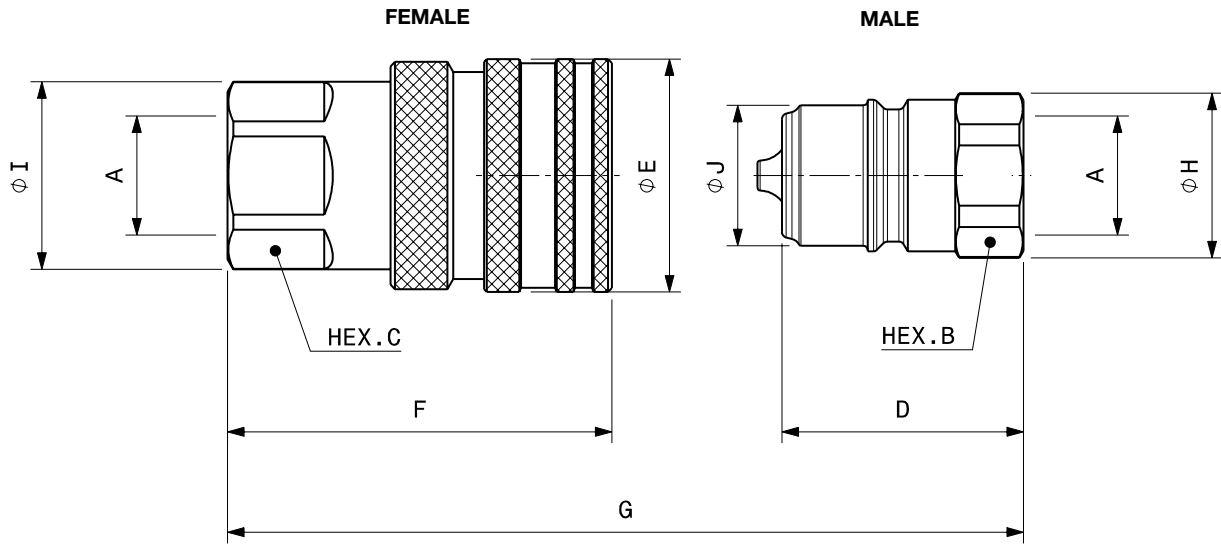

Port description: FEMALE THREAD BSPP (ISO 1179-1)

BODY SIZE	Descriptive Code	Item Code	PORT (A)	Overall Length	Length		Hex		Diameter		Diameter		Weight							
					mm	inch	mm	inch	mm	inch	mm	inch	mm	inch	Kg	Lbs				
1/4"	F IRC14 BSP	Female 812100000	1/4"	G	81,7	3,22	F	60,0	2,36	C	21,0	0,83	I	21,0	0,83	E	26,0	1,02	0,15	0,32
	M IRC14 BSP	Male 812100001					D	48,2	1,90	B	19,0	0,75	H	21,0	0,83	J	12,0	0,47	0,05	0,11
3/8"	F IRC38 BSP	Female 812100002	3/8"	G	76,4	3,01	F	61,6	2,43	C	24,0	0,94	I	26,0	1,02	E	35,0	1,38	0,22	0,48
	M IRC38 BSP	Male 812100003					D	38,0	1,50	B	22,0	0,87	H	24,0	0,94	J	19,9	0,78	0,06	0,12
1/2"	F IRC12 BSP	Female 812100004	1/2"	G	85,2	3,35	F	67,6	2,66	C	30,0	1,18	I	33,0	1,30	E	41,0	1,61	0,33	0,72
	M IRC12 BSP	Male 812100005					D	42,5	1,67	B	27,0	1,06	H	29,0	1,14	J	24,7	0,97	0,10	0,21
3/4"	F IRC34 BSP	Female 812100006	3/4"	G	94,6	3,72	F	76,2	3,00	C	38,0	1,50	I	41,6	1,64	E	52,0	2,05	0,58	1,27
	M IRC34 BSP	Male 812100007					D	47,0	1,85	B	36,0	1,42	H	39,0	1,54	J	32,7	1,29	0,19	0,41
1"	F IRC100 BSP	Female 812100008	1"	G	113,4	4,46	F	92,0	3,62	C	45,0	1,77	I	48,0	1,89	E	62,0	2,44	0,97	2,14
	M IRC100 BSP	Male 812100009					D	56,5	2,22	B	45,0	1,77	H	48,0	1,89	J	40,9	1,61	0,35	0,77

Port description: FEMALE THREAD BSPP (ISO 1179-1)

PC version poppet sealing system connectable under pressure

BODY SIZE	Descriptive Code	Item Code	PORT (A)	Overall Length	Length		Hex		Diameter		Diameter		Weight							
					mm	inch	mm	inch	mm	inch	mm	inch	mm	inch	Kg	Lbs				
3/8"	F IRC38PC BSP	Female 812100010	3/8"	G	76,4	3,01	F	61,6	2,43	C	24,0	0,94	I	26,0	1,02	E	35,0	1,38	0,22	0,48
	M IRC38PC BSP	Male 812100011					D	38,0	1,50	B	22,0	0,87	H	24,0	0,94	J	19,9	0,78	0,06	0,12
1/2"	F IRC12PC BSP	Female 812100012	1/2"	G	85,2	3,35	F	67,6	2,66	C	30,0	1,18	I	33,0	1,30	E	41,0	1,61	0,33	0,72
	M IRC12PC BSP	Male 812100013					D	42,5	1,67	B	27,0	1,06	H	29,0	1,14	J	24,7	0,97	0,10	0,21
3/4"	F IRC34PC BSP	Female 812100014	3/4"	G	94,6	3,72	F	76,2	3,00	C	38,0	1,50	I	41,6	1,64	E	52,0	2,05	0,58	1,27
	M IRC34PC BSP	Male 812100015					D	47,0	1,85	B	36,0	1,42	H	39,0	1,54	J	32,7	1,29	0,19	0,41
1"	F IRC100PC BSP	Female 812100016	1"	G	113,4	4,46	F	92,0	3,62	C	45,0	1,77	I	48,0	1,89	E	62,0	2,44	0,97	2,14
	M IRC100PC BSP	Male 812100017					D	56,5	2,22	B	45,0	1,77	H	48,0	1,89	J	40,9	1,61	0,35	0,77

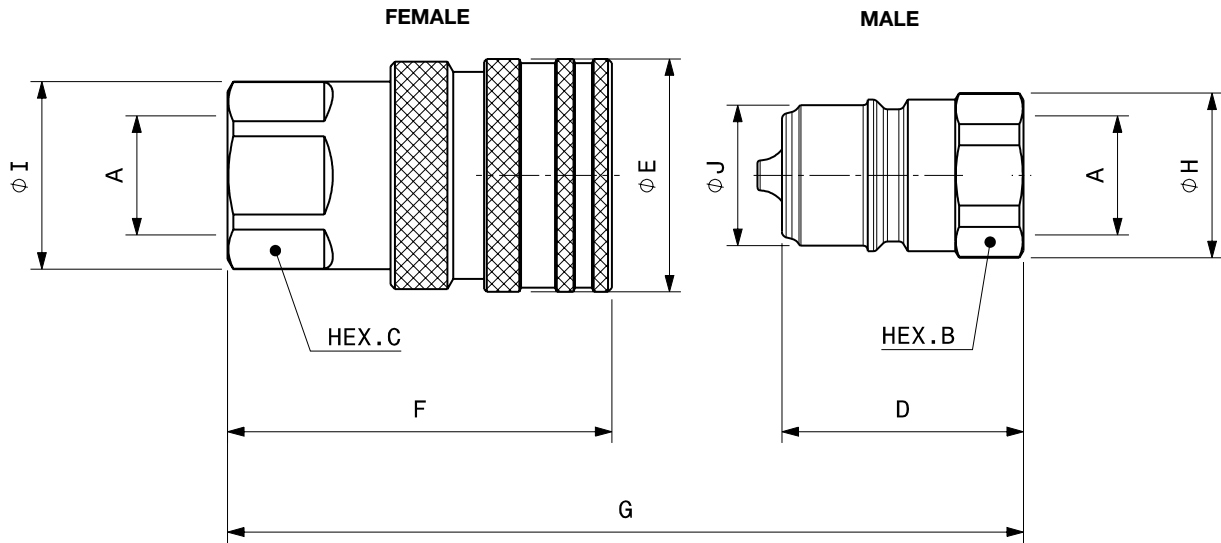

Port description: FEMALE THREAD NPTF (ANSI B.1.20.3)

BODY SIZE	Descriptive Code	Item Code	PORT (A)	Overall Length	Length		Hex		Diameter		Diameter		Weight							
					mm	inch	mm	inch	mm	inch	mm	inch	mm	inch	Kg	Lbs				
1/4"	F IRC14 NPTF	Female 812102000	1/4"	G	81,7	3,22	F	60,0	2,36	C	21,0	0,83	I	21,0	0,83	E	26,0	1,02	0,15	0,32
	M IRC14 NPTF	Male 812102001					D	48,2	1,90	B	19,0	0,75	H	21,0	0,83	J	12,0	0,47	0,05	0,11
3/8"	F IRC38 NPTF	Female 812102002	3/8"	G	76,4	3,01	F	61,6	2,43	C	24,0	0,94	I	26,0	1,02	E	35,0	1,38	0,22	0,49
	M IRC38 NPTF	Male 812102003					D	38,0	1,50	B	22,0	0,87	H	24,0	0,94	J	19,9	0,78	0,06	0,13
1/2"	F IRC12 NPTF	Female 812102004	1/2"	G	85,2	3,35	F	67,6	2,66	C	30,0	1,18	I	33,0	1,30	E	41,0	1,61	0,33	0,72
	M IRC12 NPTF	Male 812102005					D	42,5	1,67	B	27,0	1,06	H	29,0	1,14	J	24,7	0,97	0,10	0,22
3/4"	F IRC34 NPTF	Female 812102006	3/4"	G	94,6	3,72	F	76,2	3,00	C	38,0	1,50	I	41,6	1,64	E	52,0	2,05	0,58	1,27
	M IRC34 NPTF	Male 812102007					D	47,0	1,85	B	36,0	1,42	H	39,0	1,54	J	32,7	1,29	0,19	0,42
1"	F IRC100 NPTF	Female 812102008	1"	G	113,4	4,46	F	92,0	3,62	C	45,0	1,77	I	48,0	1,89	E	62,0	2,44	0,97	2,14
	M IRC100 NPTF	Male 812102009					D	56,5	2,22	B	45,0	1,77	H	48,0	1,89	J	40,9	1,61	0,35	0,78

Port description: FEMALE THREAD NPTF (ANSI B.1.20.3)

PC version poppet sealing system connectable under pressure

BODY SIZE	Descriptive Code	Item Code	PORT (A)	Overall Length	Length		Hex		Diameter		Diameter		Weight							
					mm	inch	mm	inch	mm	inch	mm	inch	Kg	Lbs						
3/8"	F IRC38PC NPTF	Female 812102010*	3/8"	G	76,4	3,01	F	61,6	2,43	C	24,0	0,94	I	26,0	1,02	E	35,0	1,38	0,22	0,49
	M IRC38PC NPTF	Male 812102011*					D	38,0	1,50	B	22,0	0,87	H	24,0	0,94	J	19,9	0,78	0,06	0,13
1/2"	F IRC12PC NPTF	Female 812102012	1/2"	G	85,2	3,35	F	67,6	2,66	C	30,0	1,18	I	33,0	1,30	E	41,0	1,61	0,33	0,72
	M IRC12PC NPTF	Male 812102013					D	42,5	1,67	B	27,0	1,06	H	29,0	1,14	J	24,7	0,97	0,10	0,22
3/4"	F IRC34PC NPTF	Female 812102014	3/4"	G	94,6	3,72	F	76,2	3,00	C	38,0	1,50	I	41,6	1,64	E	52,0	2,05	0,58	1,27
	M IRC34PC NPTF	Male 812102015					D	47,0	1,85	B	36,0	1,42	H	39,0	1,54	J	32,7	1,29	0,19	0,42
1"	F IRC100PC NPTF	Female 812102016	1"	G	113,4	4,46	F	92,0	3,62	C	45,0	1,77	I	48,0	1,89	E	62,0	2,44	0,97	2,14
	M IRC100PC NPTF	Male 812102017					D	56,5	2,22	B	45,0	1,77	H	48,0	1,89	J	40,9	1,61	0,35	0,78

* Available upon request.



SPARE PARTS: SEAL KIT FOR FEMALE

Repair kit / OR+BK			
Body Size	NBR	Description	Part Number
1/4"	F IRC14	815700700
3/8"	F IRC38	815700702
1/2"	F IRC12	815700704
3/4"	F IRC34	815700706
1"	F IRC100	815700708

BackUp ring in Teflon®

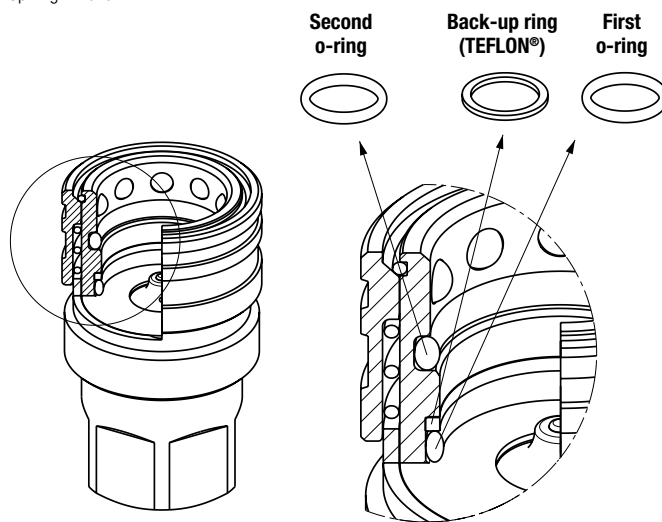

PROTECTIVE CAPS FOR IRC SERIES

Protective caps are always recommended to protect the couplings from damage, dirt inclusion, and will increase the product life. This is particularly important in mobile applications where exposure to weather and aggregate materials are common.

The protective caps for IRC couplings are manufactured in plastic with connection lanyard.

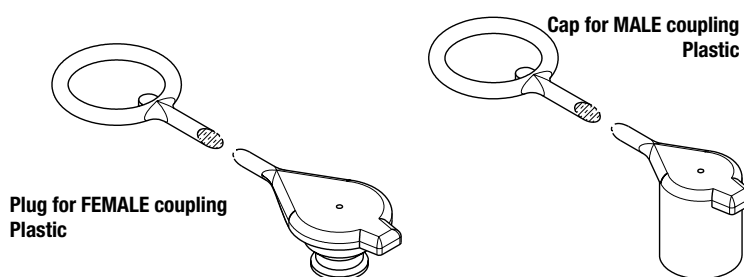

Body Size/Description	Protective Cap		Material/Color
	Plug for Female	Cap for Male	
1/4" IRC14	815000042	815000043	Plastic/Red
3/8" IRC38	815000044	815000045	Plastic/Red
1/2" IRC12	815000046	815000047	Plastic/Red
3/4" IRC34	815000048	815000049	Plastic/Red
1" IRC100	815000050	815000051	Plastic/Red



IRCXSERIES

INTERCHANGE > with similar product (Nordic interface)



TECHNICAL FEATURES AND OPTIONS

Interchange With similar product (Nordic interface)	Sealing description VITON®	Connection system Single acting sleeve
Available sizes From 1/4" to 1"	Material Stainless steel (AISI 316L)	Available threads BSP
Operating pressure Up to 300 bar	Locking mechanism Ball locking + safety sleeve	Flow rate Up to 378 l/min
Temperature (°C) -20° / +100°	Valving style Poppet	Connection under pressure Not allowed

BENEFITS

- The poppet valve with elastomer seal provides maximum sealing of the couplings once disconnected.
- O-Ring + BackUp ring for optimum protection sealing.
- Additional O-Ring for extra sealing capacity and to contain spray effect to avoid soil contamination.
- High durability.
- Reference products for tough applications, typically used in Nordic countries.
- Safety sleeve to prevent accidental disconnection.
- Shape of internal parts is optimized to reduce turbulence and pressure drop.
- High resistance to pressure impulses.
- Compact design.
- Simple to use.

HOW TO USE

- Before to connect, clean the mating surface of the couplings to avoid dirt inclusion in the circuit.
- To connect: pull back the sleeve of the female coupling, align the female with the male coupling and push one into the other until both halves are fully connected and release the sleeve.
- To avoid accidental disconnection rotate safety sleeve.
- To disconnect: unlock the safety sleeve and pull back the sleeve of the female coupling, pull out the mating half.

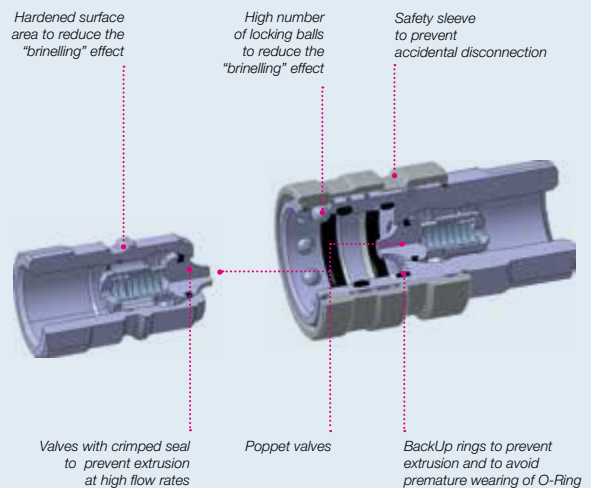
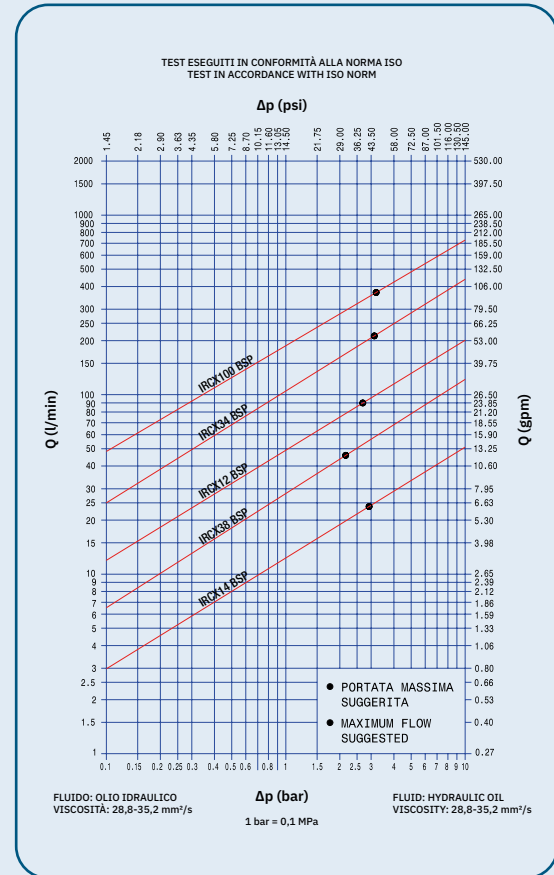

MAIN APPLICATIONS

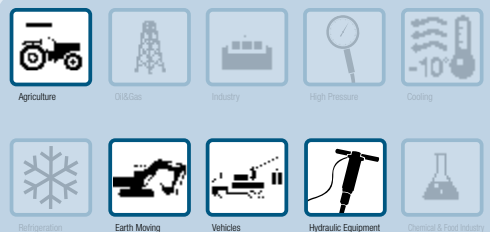

PERFORMANCES

Size		Series/Size	Max. flow suggested		Connect force		Disconnect force		Spillage*
Inch	mm		l/min	gpm	N	lbf	N	lbf	ml
1/4	6,3	IRC14	24	6,36	60	13,48	30	6,74	1,1
3/8	10	IRC38	46	12,19	90	20,23	35	7,86	2,5
1/2	12,5	IRC12	90	23,85	120	26,97	35	7,86	3,5
3/4	20	IRC34	212	56,18	170	38,21	45	10,11	15
1	25	IRC100	378	100,17	210	47,20	45	10,11	18

Size	Series/Size	Max. operating pressure						Burst pressure					
		Coupled		Male		Female		Coupled		Male		Female	
Inch	Stainless steel	MPa	psi	MPa	psi	MPa	psi	MPa	psi	MPa	psi	MPa	psi
1/4	IRC14X	30	4350	30	4350	30	4350	120	17400	120	17400	120	17400
3/8	IRC38X	30	4350	25	3625	25	3625	120	17400	100	14500	100	14500
1/2	IRC12X	30	4350	25	3625	25	3625	120	17400	100	14500	100	14500
3/4	IRC34X	20	2900	20	2900	20	2900	80	11600	80	11600	80	11600
1	IRC100X	20	2900	15	2175	15	2175	80	11600	60	8700	60	8700

* Spillage is an indicative value of the fluid loss during disconnection (according to ISO norm test method).

Material:

- Construction: Stainless steel AISI 316L
- Springs: AISI 302
- Locking ball: AISI 316

Different configuration possible

PL version (free flow without valve): available upon request.

SAE thread available upon request.

Temperature range:

Seals in VITON®: from -15°C to +180°C (from +5 °F to +356 °F).

Please read carefully Instructions and warnings for proper selection of the products.

Tests performed:

The couplings have been tested at max. operating pressure for 200.000 impulses according to ISO norm test method.



WARNING

A defect, a wrong choice or an improper use of products, can cause injury to persons, animals and objects.

Never connect or disconnect with dynamic pressure (e.g. pump on).

Do not use the coupling disconnected with high impulse pressure.

Do not couple-uncouple with flow and/or pressure in the circuit.

Do not couple-uncouple when the temperature inside of the circuit is higher than 80 °C (176 °F).

Check the maximum allowable working pressure of the port in use.

Make sure that the medium used is compatible with seal and material as indicated for each series.

In case of doubt please contact Stucchi Technical Support.

The interchangeability is mentioned under the assumption that the manufacturer of the considered products has not changed any dimension.

It is mandatory to carefully read and closely follow the instructions before selecting or using any Stucchi products.

Always refer to the version uploaded in the Instructions and warning section of stucchigroup.com website for the latest release.

For specific, product-related, instructions, please contact Stucchi technical service.

OVERALL DIMENSIONS

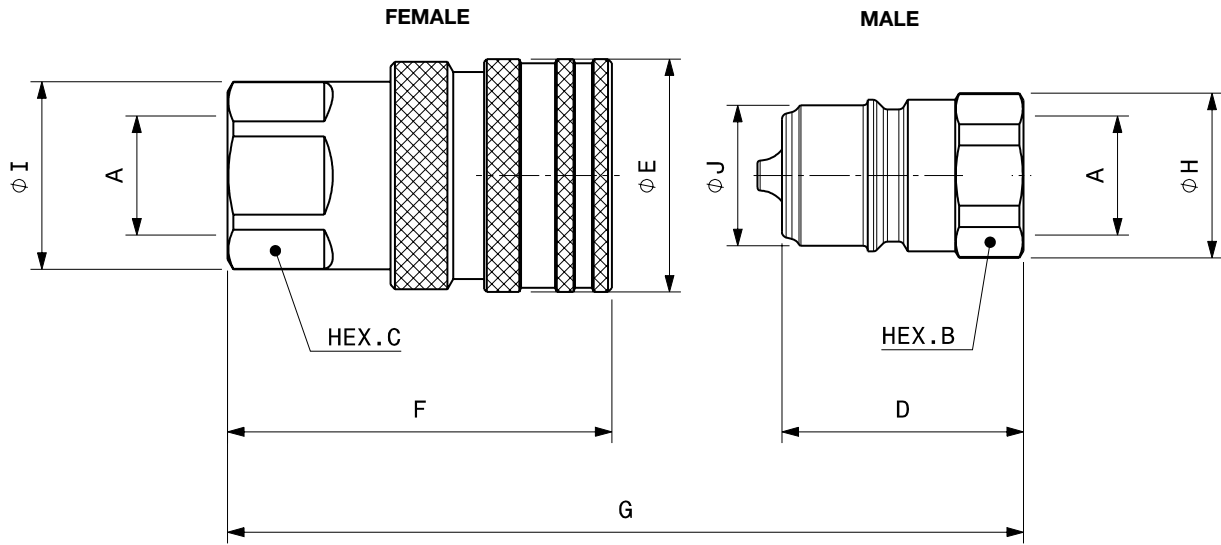

Port description: FEMALE THREAD BSPP (ISO 1179-1 & DIN 3852-2 form X)

BODY SIZE	Descriptive Code	Item Code	PORT (A)	Overall Length	Length		Hex		Diameter		Diameter		Weight							
					mm	inch	mm	inch	mm	inch	mm	inch	Kg	Lbs						
1/4"	F IRC14X BSP	Female 808900100	1/4"	G	81,7	3,22	F	61,6	2,36	C	24,0	0,83	I	23,0	0,83	E	26,0	1,02	0,15	0,32
	M IRC14X BSP	Male 808900101					D	38,0	1,90	B	22,0	0,75	H	24,5	0,83	J	12,0	0,47	0,05	0,11
3/8"	F IRC38X BSP	Female 808900102	3/8"	G	76,4	3,01	F	67,6	2,43	C	30,0	0,94	I	26,0	1,02	E	35,0	1,38	0,22	0,48
	M IRC38X BSP	Male 808900103					D	42,5	1,50	B	27,0	0,87	H	24,0	0,94	J	19,9	0,78	0,06	0,12
1/2"	F IRC12X BSP	Female 808900104	1/2"	G	85,2	3,35	F	76,2	2,66	C	38,0	1,18	I	33,0	1,30	E	41,0	1,61	0,33	0,72
	M IRC12X BSP	Male 808900105					D	47,0	1,67	B	36,0	1,06	H	29,0	1,14	J	24,7	0,97	0,10	0,21
3/4"	F IRC34X BSP	Female 808900106	3/4"	G	94,6	3,72	F	92,0	3,00	C	45,0	1,50	I	41,6	1,64	E	52,0	2,05	0,58	1,27
	M IRC34X BSP	Male 808900107					D	56,5	1,85	B	45,0	1,42	H	39,0	1,54	J	32,7	1,29	0,19	0,41
1"	F IRC100X BSP	Female 808900108	1"	G	113,4	4,46	F	92,0	3,62	C	45,0	1,77	I	48,0	1,89	E	62,0	2,44	0,97	2,14
	M IRC100X BSP	Male 808900109					D	56,5	2,22	B	45,0	1,77	H	48,0	1,89	J	40,9	1,61	0,35	0,77



SPARE PARTS: SEAL KIT FOR FEMALE

Repair kit / OR+BK			
Body Size	NBR	Version Description	Part Number
1/4"		F IRC14X	815700978
3/8"		F IRC38X	815700980
1/2"		F IRC12X	815700982
3/4"		F IRC34X	815700984
1"		F IRC100X	815700986

BackUp ring in Teflon®

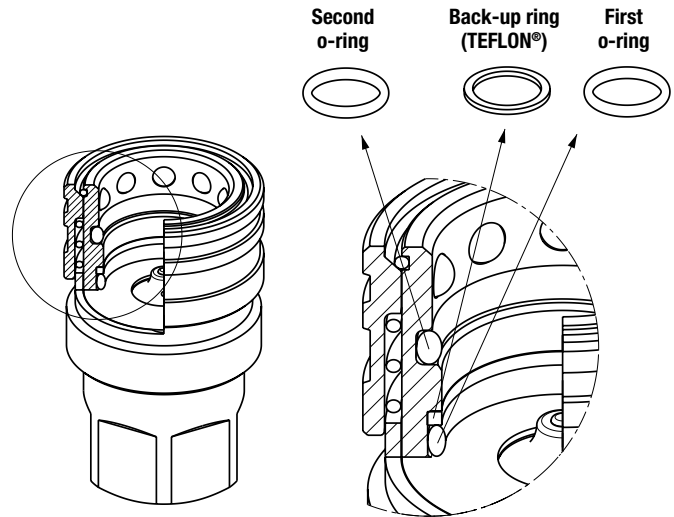

PROTECTIVE CAPS FOR IRC SERIES

Protective caps are always recommended to protect the couplings from damage, dirt inclusion, and will increase the product life. This is particularly important in mobile applications where exposure to weather and aggregate materials are common.

The protective caps for IRC couplings are manufactured in plastic with connection lanyard.

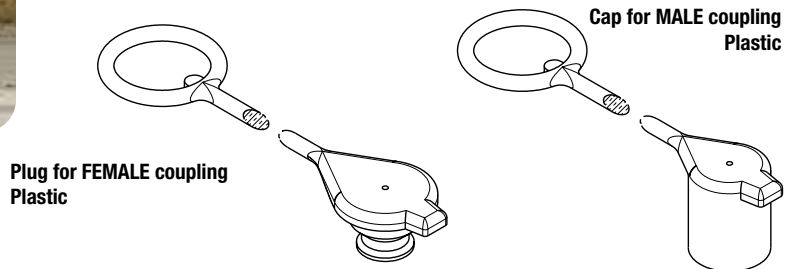

Body Size/Description		Protective Cap		Material/Color
		Part Number	Part Number	
		Plug for Female	Cap for Male	
1/4"	IRC14	815009042	815009043	PVC/GREY
3/8"	IRC38	815009044	815009045	PVC/GREY
1/2"	IRC12	815009046	815009047	PVC/GREY
3/4"	IRC34	815009048	815009049	PVC/GREY
1"	IRC100	815009050	815009051	PVC/GREY



IFR SERIES

INTERCHANGE > ISO 5676 "NF U 16-006"



TECHNICAL FEATURES AND OPTIONS

Interchange ISO 5676 "NF U 16-006"	Sealing description Nitrile NBR	Connection system Single acting sleeve
Available sizes 3/8"	Material/treatment Carbon steel /Cr3	Available threads BSP - METRIC
Operating pressure Up to 150 bar	Locking mechanism Locking Ball system	Flow rate Up to 46 l/min
Temperature (°C) -20° / +100°	Valving style Flat face Non spill	Connection under pressure Connection: not allowed Disconnection: not allowed

BENEFITS

- Minimal fluid spillage during disconnection, reducing fluid spillage to the environment.
- Minimal air inclusion during connection.
- Compact slim design.
- Simple to use.
- Metallic plug for female and plastic cap for male are included with the couplings.

HOW TO USE

- Before to connect, clean the mating surface of the couplings to avoid dirt inclusion in the circuit.
- To connect pull back the sleeve of the female coupling, align the female with the male coupling and push one into the other until both halves are fully connected and release the sleeve.
- To disconnect push back the sleeve of the female coupling, pull out the mating half.

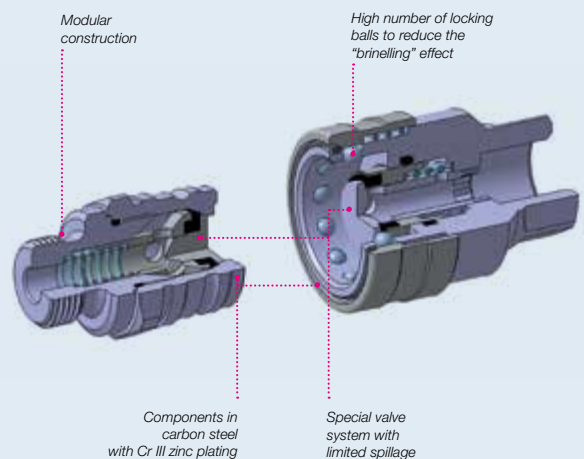
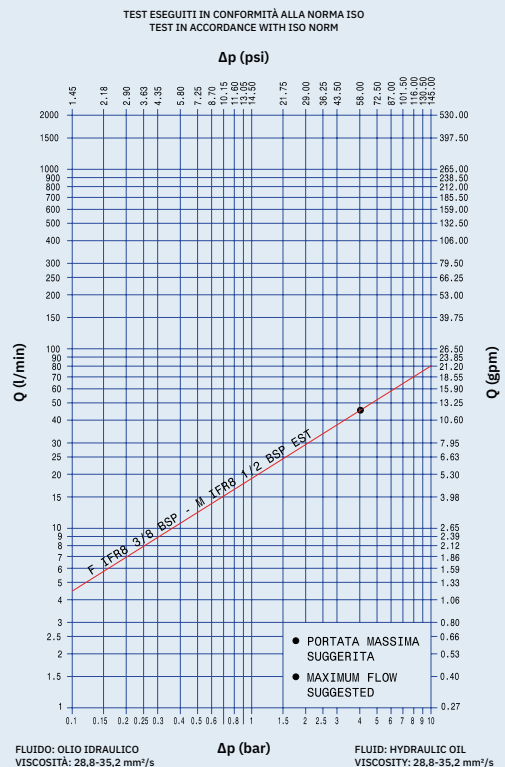

MAIN APPLICATIONS



POPET SCREW



PERFORMANCES

Size		Series/Size	Max. flow suggested		Connect force		Disconnect force		Spillage*
Inch	mm		l/min	gpm	N	lbf	N	lbf	ml
3/8	6,3	IFR8	46	12,15	170	38,25	27	6,08	0,06

Size	Series/Size	Max. operating pressure						Burst pressure					
		Coupled		Male		Female		Coupled		Male		Female	
		MPa	psi	MPa	psi	MPa	psi	MPa	psi	MPa	psi	MPa	psi
3/8	IFR8	15	2175	15	2175	15	2175	100	14500	80	11600	30	4350

* Spillage is an indicative value of the fluid loss during disconnection (according to ISO norm test method).

Different possible configurations:

Female without plug available upon request.
Different threads available upon request.

Temperature range:

Standard seal NBR (Nitrile): from -20 °C to +100 °C (from -4 °F to +212 °F).
Please read carefully Instructions and warnings for proper selection of the products.

Tests:

The couplings have been tested at max. operating pressure for 100.000 impulses according to ISO norm test method.



WARNING

A defect, a wrong choice or an improper use of products, can cause injury to persons, animals and objects.

Never connect or disconnect with dynamic pressure (e.g. pump on).

Do not use the coupling disconnected with high impulse pressure.

Do not couple-uncouple with flow and/or pressure in the circuit.

Do not couple-uncouple when the temperature inside of the circuit is higher than 80 °C (176 °F).

Check the maximum allowable working pressure of the port in use.

Make sure that the medium used is compatible with seal and material as indicated for each series.

In case of doubt please contact Stucchi Technical Support.

The interchangeability is mentioned under the assumption that the manufacturer of the considered products has not changed any dimension.

It is mandatory to carefully read and closely follow the instructions before selecting or using any Stucchi products.

Always refer to the version uploaded in the Instructions and warning section of stucchigroup.com website for the latest release.

For specific, product-related, instructions, please contact Stucchi technical service.

OVERALL DIMENSIONS

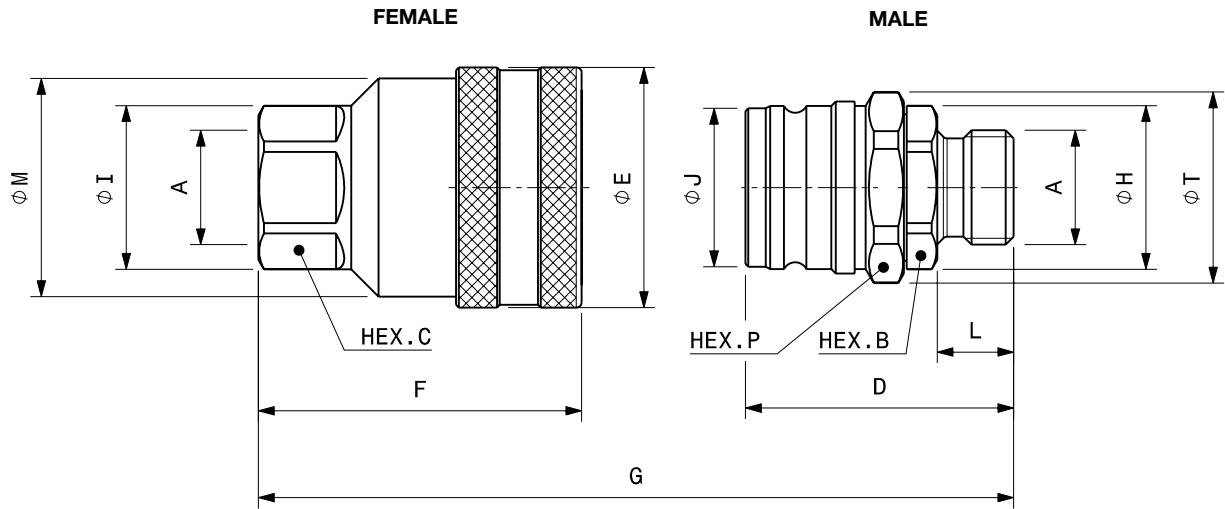

Port description: FEMALE THREAD BSP (ISO 1179-1) FEMALE THREAD METRIC

BODY SIZE	Descriptive Code	Item Code	ISO DN	PORT (A)	Overall Length		Length		Hex		Diameter		Diameter		Diameter							
					mm	inch	mm	inch	mm	inch	mm	inch	mm	inch	mm	inch						
3/8"	F IFR8 3/8 BSP	Female 800200048	6,3	G3/8"	G	G = F+D-15	G = F+D-0.59	F	56,2	2,21	C	27,0	1,06	M	40,0	1,57	I	30,0	1,18	E	44,0	1,73
3/8"	F IFR8 1/2 BSP	Female 800200050	6,3	G 1/2"	G	G = F+D-15	G = F+D-0.59	F	59,2	2,33	C	27,0	1,06	M	40,0	1,57	I	30,0	1,18	E	44,0	1,73
3/8"	F IFR8 M18X1.5	Female 800212000	6,3	M18X1.5	G	G = F+D-15	G = F+D-0.59	F	54,2	2,13	C	27,0	1,06	M	40,0	1,57	I	30,0	1,18	E	44,0	1,73

Descriptive Code	Item Code	Weight	
		Kg	Lbs
F IFR8 3/8 BSP	Female 800200048	0,36	0,80
F IFR8 1/2 BSP	Female 800200050	0,43	0,94
F IFR8 M18X1.5	Female 800212000	0,36	0,80

Port description: MALE THREAD BSP (DIN 3852-2 form A) MALE THREAD METRIC L series 24° (ISO 8434-1 & DIN 2353)

BODY SIZE	Descriptive Code	Item Code	ISO DN	PORT (A)	Overall Length		Length		Length		Hex		Hex		Diameter							
					mm	inch	mm	inch	mm	inch	mm	inch	mm	inch	mm	inch						
3/8"	M IFR8 1/2 BSP EST	Male 800200051	6,3	G 1/2"	G	G = F+D-15	G = F+D-0.59	D	49,1	1,93	L	14,0	0,55	B	27,0	1,06	P	32,0	1,26	T	35,0	1,38
3/8"	M IFR8 L12 SCHOTT 23	Male 800210003	6,3	M18X1.5	G	G = F+D-15	G = F+D-0.59	D	58,1	2,29	L	23,0	0,91	B	27,0	1,06	P	32,0	1,26	T	35,0	1,38
3/8"	M IFR8 L12 SCHOTT 30	Male 800210005	6,3	M18X1.5	G	G = F+D-15	G = F+D-0.59	D	65,1	2,56	L	30,0	1,18	B	27,0	1,06	P	32,0	1,26	T	35,0	1,38
3/8"	M IFR8 M20X1,5 EST	Male 800215003	6,3	M20X1.5	G	G = F+D-15	G = F+D-0.59	D	58,1	2,29	L	23,0	0,91	B	27,0	1,06	P	32,0	1,26	T	35,0	1,38

Descriptive Code	Item Code	Diameter		Diameter		Weight			
		mm	inch	mm	inch	Kg	Lbs		
M IFR8 1/2 BSP EST	Male 800200051	H	30,0	1,18	J	29,0	1,14	0,19	0,42
M IFR8 L12 SCHOTT 23	Male 800210003	H	30,0	1,18	J	29,0	1,14	0,19	0,43
M IFR8 L12 SCHOTT 30	Male 800210005	H	30,0	1,18	J	29,9	1,18	0,20	0,45
M IFR8 M20X1,5 EST	Male 800215003	H	30,0	1,18	J	29,0	1,14	0,20	0,44



PROTECTIVE CAPS FOR IFR SERIES

Protective caps are always recommended to protect the couplings from damage, dirt inclusion, and will increase the product life. This is particularly important in agricultural applications where exposure to weather and aggregate materials are common.

Metallic plug for female and plastic cap for male are included with the IFR couplings.

- The plug for female coupling is in carbon steel Cr III zinc plated.
- The standard color of plastic cap for male coupling is Yellow.
- Temperature range: from -20°C to +100°C.

Plug for FEMALE coupling
Carbon steel

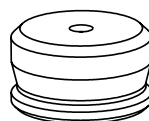

Cap for MALE coupling
Yellow plastic

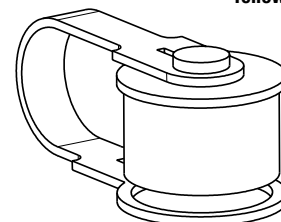

Protective Cap			
Body Size/Description		Part Number	
		Metallic plug for Female	Plastic cap for Male
3/8"	IFR8	815701120	814901027





A-HP

p. 215

Valving style: Flat Face
Interchange: Stucchi profile
Sealing description: Nitrile NBR
Available sizes: From 1/8" to 3/8"
Operating pressure: Up to 700 bar
Flow rate: Up to 46 l/min
Material / Treatment:
Carbon steel / Cr3



IV-HP

p. 219

Valving style: Ball
Interchange: With similar couplings
(high pressure)
Sealing description: Nitrile NBR
Available sizes: From 1/4" to 3/8"
Operating pressure: Up to 700 bar
Flow rate: Up to 23 l/min
Material / Treatment:
Carbon steel / Cr3



A-HP SERIES

INTERCHANGE > Stucchi profile



TECHNICAL FEATURES AND OPTIONS

Interchange Stucchi profile	Sealing description Nitrile NBR	Connection system Push
Available sizes from 1/8" to 3/8"	Material/treatment Carbon steel /Cr3	Available threads BSP - NPT
Operating pressure Up to 700 bar	Locking mechanism Locking Ball + Safety sleeve	Flow rate Up to 46 l/min
Temperature (°C) -20° / +100°	Valving style Flat face	Connection under pressure Connection: not allowed Disconnection: not allowed

BENEFITS

- Flat face is easy to clean, reducing the inclusion of contamination inside the hydraulic circuit.
- Minimal fluid spillage during disconnection, reducing fluid spillage to the environment.
- Minimal air inclusion during connection.
- Internal design reduces pressure drop, increasing circuit efficiency.
- Automatic safety lock to prevent accidental disconnection. This safety feature is very important mainly for the rescue equipment.
- The modular structure allows broad range of port configurations.
- Compact slim design.
- Safe and simple to use.

HOW TO USE

- Before to connect, clean the mating surface of the couplings to avoid dirt inclusion in the circuit.
- To connect push the male half towards the female half or vice versa until the coupler sleeve clicks.
- Upon connection the safety sleeve automatically rotates engaging the safety lock mechanism. In this safety lock position the coupling cannot be disconnected until the operator aligns the sleeve in the proper position (safety locking ball aligned with the notch in the coupler sleeve).
- To disconnect turn the external sleeve until the until the stop and push back the sleeve.

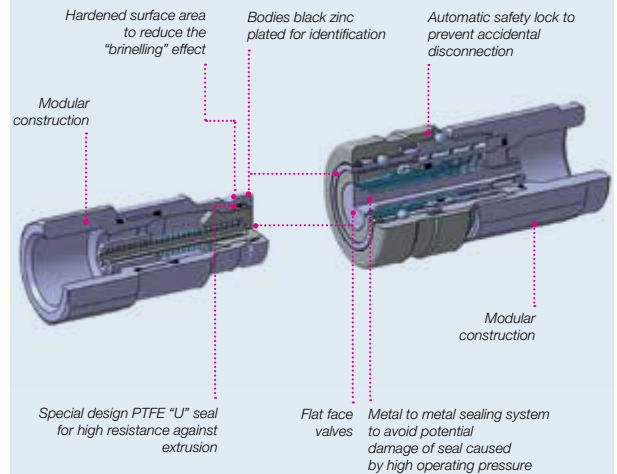
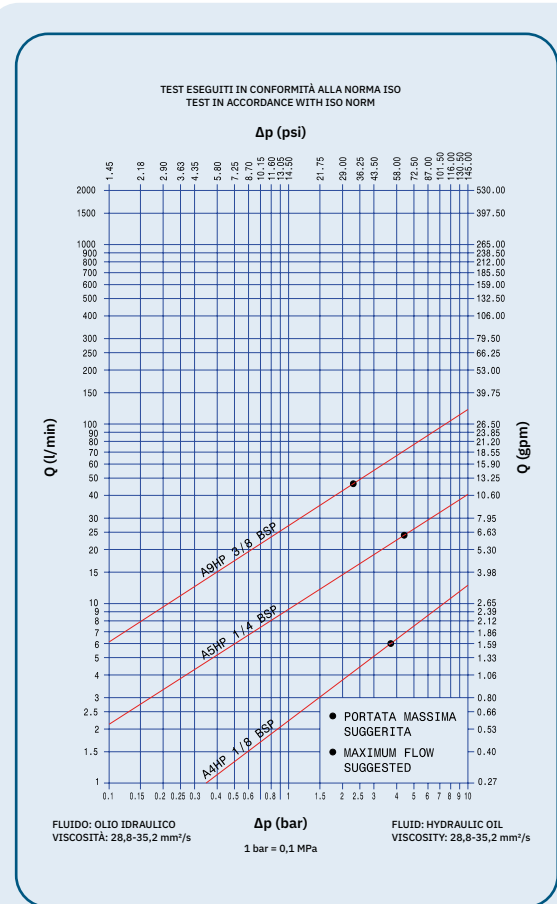

HIGH PRESSURE

MAIN APPLICATIONS

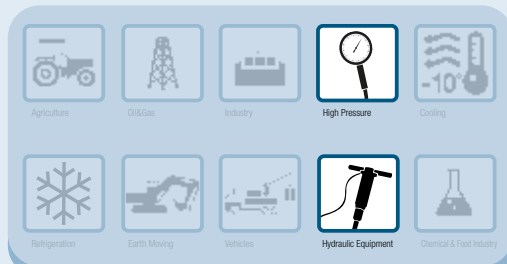

PERFORMANCES

Size	Series/Size	Max. flow suggested		Connect force		Disconnect force		Spillage*
		l/min	gpm	N	lbf	N	lbf	
1/8	A4HP	6	1,59	95	21,38	40	9,00	0,04
1/4	A5HP	24	6,36	125	28,13	45	10,13	0,02
3/8	A9HP	46	12,19	205	46,13	50	11,25	0,02

Size	Series/Size	Max. operating pressure						Burst pressure					
		Coupled		Male		Female		Coupled		Male		Female	
Inch		MPa	psi	MPa	psi	MPa	psi	MPa	psi	MPa	psi	MPa	psi
1/8	A4HP	70	10440	70	10440	70	10440	160	23200	160	23200	160	23200
1/4	A5HP	70	10440	70	10440	50	7250	200	29000	200	29000	150	21750
3/8	A9HP	70	10440	70	10440	42	6090	180	26100	200	29000	125	18125

* Spillage is an indicative value of the fluid loss during disconnection (according to ISO norm test method).

Different possible configurations:
Different threads available upon request.

Temperature range:
Standard seals NBR (Nitrile): from -20 °C to +100 °C (from -4 °F to +212 °F).
Please read carefully Instructions and warnings for proper selection of the products.

Tests:
The couplings have been tested at impulse with max. operating pressure for pressure for 100.000 impulses according to ISO norm test method.
A4HP has been tested for 10.000 impulses.

WARNING

A defect, a wrong choice or an improper use of products, can cause injury to persons, animals and objects.
Never connect or disconnect with dynamic pressure (e.g. pump on).
Do not use the female coupling disconnected with high impulse pressure.
Do not couple-uncouple with flow and/or pressure in the circuit.
Do not couple-uncouple when the temperature inside of the circuit is higher than 80 °C (176 °F).
Check the maximum allowable working pressure of the port in use.
Make sure that the medium used is compatible with seal and material as indicated for each series.
In case of doubt please contact Stucchi Technical Support.
The interchangeability is mentioned under the assumption that the manufacturer of the considered products has not changed any dimension.
It is mandatory to carefully read and closely follow the instructions before selecting or using any Stucchi products.
Always refer to the version uploaded in the Instructions and warning section of stucchigroup.com website for the latest release.
For specific, product-related, instructions, please contact Stucchi technical service.

OVERALL DIMENSIONS

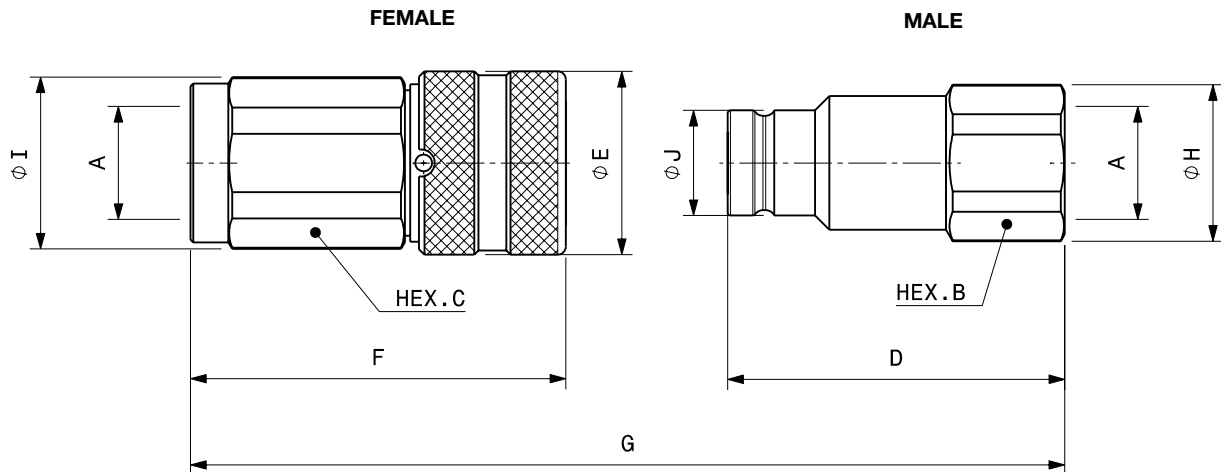

Port description: FEMALE THREAD NPT (ANSI B.1.20.1)

BODY SIZE	Descriptive Code	Item Code	PORT (A)	Overall Length		Length		Hex		Diameter		Diameter		Weight						
				mm	inch	mm	inch	mm	inch	mm	inch	mm	inch	Kg	Lbs					
1/8"	F A4HP 1/8 NPT	Female 801601014	1/8"	G	72,3	2,85	F	44,0	1,73	C	17,0	0,67	I	21,8	0,86	E	22,0	0,87	0,09	0,20
	M A4HP 1/8 NPT	Male 801601015					D	36,2	1,43	B	17,0	0,67	H	18,5	0,73	J	12,0	0,47	0,04	0,09
1/4"	F A5HP 1/4 NPT	Female 801601004	1/4"	G	94,9	3,74	F	58,0	2,28	C	22,0	0,87	I	29,0	1,14	E	29,0	1,14	0,21	0,45
	M A5HP 1/4 NPT	Male 801601005					D	47,9	1,89	B	22,0	0,87	H	23,8	0,94	J	16,5	0,65	0,09	0,20
1/4"	F A5HP 3/8 NPT	Female 801601008	3/8"	G	103,9	4,09	F	60,0	2,36	C	24,0	0,94	I	29,0	1,14	E	29,0	1,14	0,21	0,46
	M A5HP 3/8 NPT	Male 801601009					D	54,9	2,16	B	24,0	0,94	H	26,0	1,02	J	16,5	0,65	0,11	0,24
3/8"	F A9HP 3/8 NPT	Female 801601010	3/8"	G	108,8	4,28	F	64,6	2,54	C	30,0	1,18	I	32,0	1,26	E	34,0	1,34	0,32	0,71
	M A9HP 3/8 NPT	Male 801601011					D	60,0	2,36	B	27,0	1,06	H	29,0	1,14	J	19,5	0,77	0,15	0,34
3/8"	F A9HP 1/2 NPT	Female 801601012	1/2"	G	116,3	4,58	F	69,6	2,74	C	30,0	1,18	I	32,0	1,26	E	34,0	1,34	0,31	0,68
	M A9HP 1/2 NPT	Male 801601013					D	62,5	2,46	B	27,0	1,06	H	29,0	1,14	J	19,5	0,77	0,14	0,32



IV-HP SERIES

INTERCHANGE > with similar couplings (High Pressure)



TECHNICAL FEATURES AND OPTIONS

Interchange With similar couplings (High Pressure)	Sealing description Nitrile NBR	Connection system Screw
Available sizes from 1/4" to 3/8"	Material/treatment Carbon steel /Cr3	Available threads NPT
Operating pressure Up to 700 bar	Locking mechanism Screw to connect	Flow rate Up to 23 l/min
Temperature (°C) -20° / +100°	Valving style Ball	Connection under pressure Connection: not allowed Disconnection: not allowed

BENEFITS

- Ball valves in hardened steel provide a good wearing resistance.
- Compact slim design.
- Simple to use.

HOW TO USE

- Before to connect, clean the mating surface of the couplings to avoid dirt inclusion in the circuit.
- To connect insert the male coupling in the female coupling, move forward the sleeve of the female coupling and screw it manually on the male coupling till it blocks.
- To disconnect unscrew totally the sleeve from the male coupling.

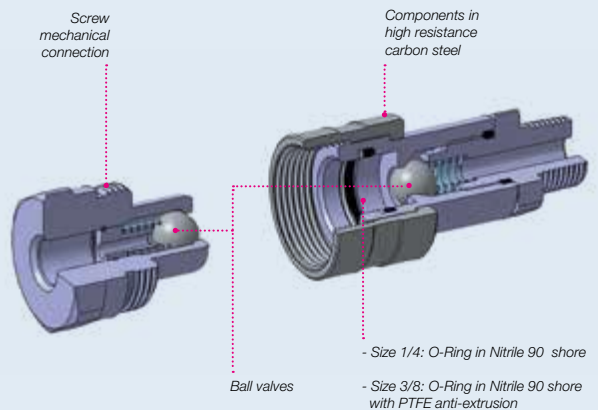
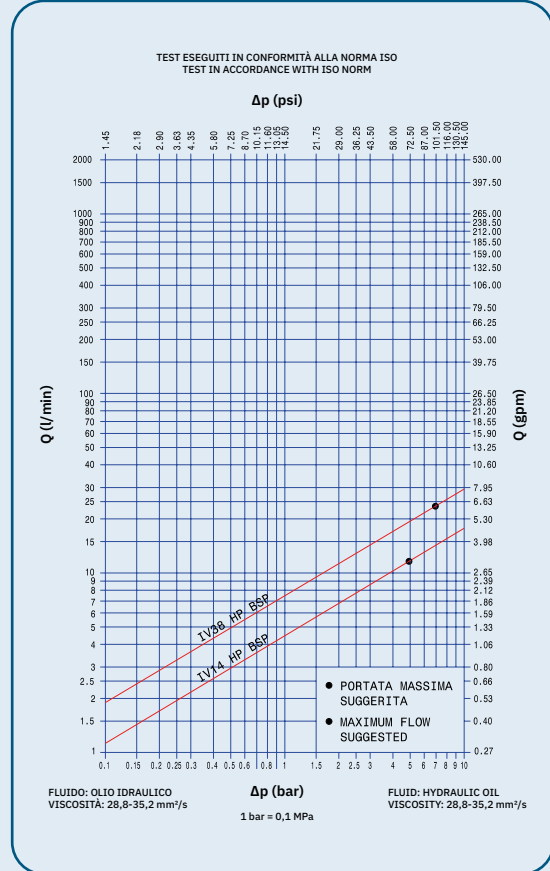

MAIN APPLICATIONS



HIGH PRESSURE

PERFORMANCES

Size	Series/Size	Max. flow suggested		Max. operating pressure	
		l/min	gpm	MPa	psi
1/4	IV14HP	12	3,18	70	10.000
3/8	IV38HP	23	6,10	70	10.000

Temperature range:

Standard seals NBR (Nitrile): from -20 °C to +100 °C (from -4 °F to +212 °F).
Please read carefully Instructions and warnings for proper selection of the products.

Different possible configurations:

Different threads available upon request.

WARNING

A defect, a wrong choice or an improper use of products, can cause injury to persons, animals and objects.
Never connect or disconnect with dynamic pressure (e.g. pump on).
Do not use the coupling disconnected with high impulse pressure.
Do not couple-uncouple with flow and/or pressure in the circuit.
Do not couple-uncouple when the temperature inside of the circuit is higher than 80 °C (176 °F).
Check the maximum allowable working pressure of the port in use.
Make sure that the medium used is compatible with seal and material as indicated for each series.
In case of doubt please contact Stucchi Technical Support.
The interchangeability is mentioned under the assumption that the manufacturer of the considered products has not changed any dimension.
It is mandatory to carefully read and closely follow the instructions before selecting or using any Stucchi products.
Always refer to the version uploaded in the Instructions and warning section of stucchigroup.com website for the latest release.
For specific, product-related, instructions, please contact Stucchi technical service.

OVERALL DIMENSIONS

Female with external thread

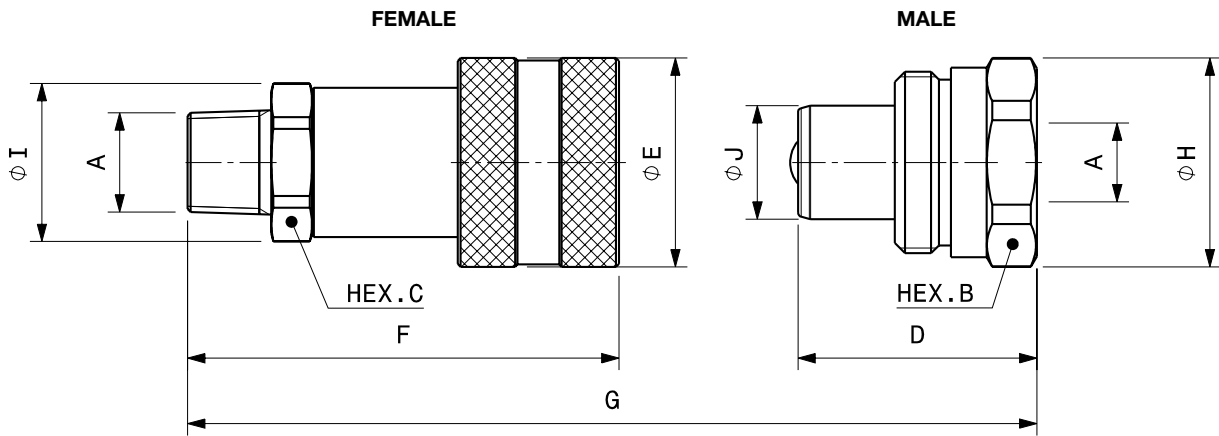

Female with internal thread

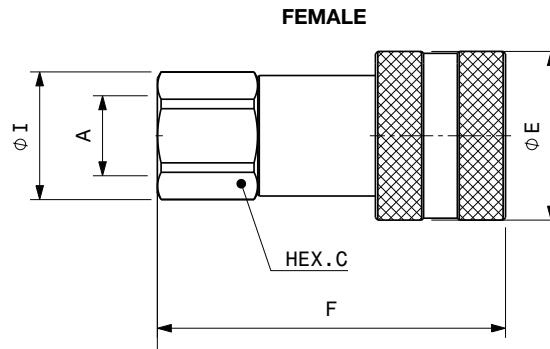

Port description: FEMALE THREAD NPT (ANSI B1.20.1) - MALE THREAD NPT (ANSI B1.20.1)

BODY SIZE	Descriptive Code	Item Code	PORT (A)	Overall Length		Length		Hex		Diameter		Diameter		Weight						
				mm	inch	mm	inch	mm	inch	mm	inch	mm	inch	Kg	Lbs					
1/4"	F IV14HP 1/4 NPT EXT	Female 800201008	1/4"			F	60,8	2,39	C	22,0	0,87	I	24,5	0,96	E	28,0	1,10	0,14	0,30	
1/4"	F IV14HP 1/4 NPT	Female 800201034	1/4"	G	74,5	2,93	F	60,8	2,39	C	22,0	0,87	I	24,5	0,96	E	28,0	1,10	0,14	0,30
1/4"	M IV14HP 1/4 NPT	Male 800201009	1/4"			D	32,5	1,28	B	19,0	0,75	H	28,0	1,10	J	15,8	0,62	0,07	0,16	
3/8"	F IV38HP 1/4 NPT EXT	Female 800201006	1/4"			F	72,3	2,85	C	24,0	0,94	I	26,5	1,04	E	35,0	1,38	0,21	0,47	
3/8"	F IV38HP 1/4 NPT	Female 800201022	1/4"	G	F+D-18,8	F+D-0,74	F	69,9	2,75	C	24,0	0,94	I	26,5	1,04	E	35,0	1,38	0,22	0,49
3/8"	M IV38HP 1/4 NPT	Male 800201023	1/4"			D	40,0	1,57	B	32,0	1,26	H	35,0	1,38	J	19,0	0,75	0,15	0,33	
3/8"	F IV38HP 3/8 NPT EXT	Female 800201004	3/8"			F	72,2	2,84	C	24,0	0,94	I	26,5	1,04	E	35,0	1,38	0,22	0,49	
3/8"	F IV38HP 3/8 NPT	Female 800201014	3/8"	G	F+D-25,4	F+D-1,00	F	72,3	2,85	C	24,0	0,94	I	26,5	1,04	E	35,0	1,38	0,24	0,52
3/8"	M IV38HP 3/8 NPT	Male 800201005	3/8"			D	40,0	1,57	B	32,0	1,26	H	35,0	1,38	J	19,0	0,75	0,14	0,31	



SPARE KIT SEAL FOR FEMALE

Repair kit / OR (+BK)		
Body Size	Description	Part Number
1/4"	OR F IV14HP	815700652
3/8"	OR+BK F IV38HP	815700650

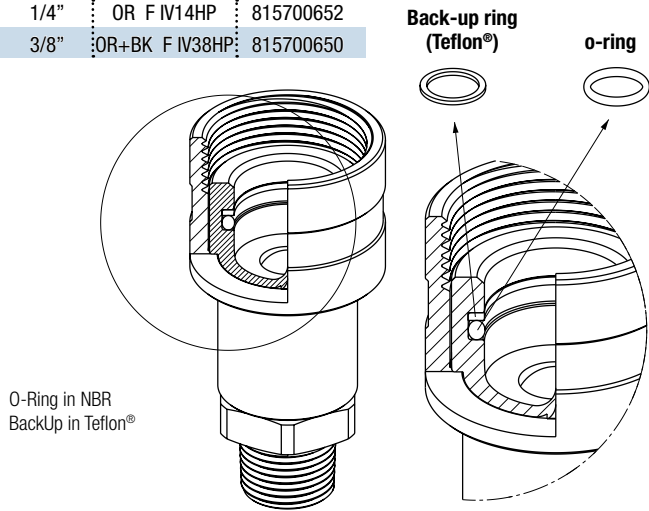

PROTECTIVE CAPS FOR IV-HP SERIES

Protective caps are always recommended to protect the couplings from damage, dirt inclusion, and will increase the product life. For the IV-HP series are available two kind of materials:

- Plastic caps with lanyard (standard color: black)
- Cr3 steel with lanyard (standard colors: natural)

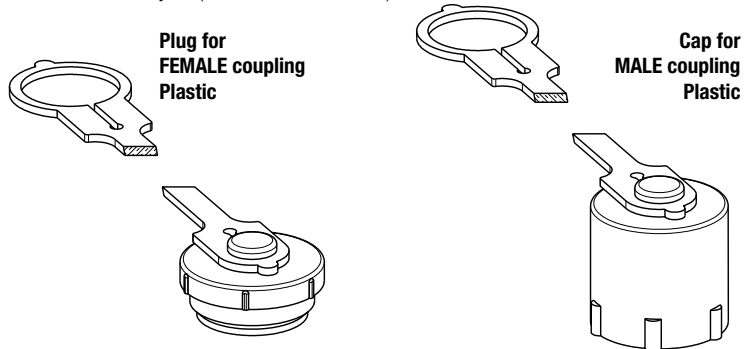

Body Size/Description	Protective Cap		Material/Color
	Plug for Female	Cap for Male	
1/4" IV14HP	815603010	815603011	Plastic/Black
3/8" IV38HP	815603012	815603013	Plastic/Black

Plug for FEMALE coupling Carbon Steel

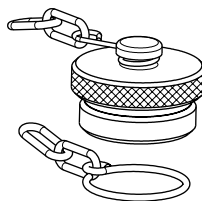

Cap for MALE coupling Carbon Steel

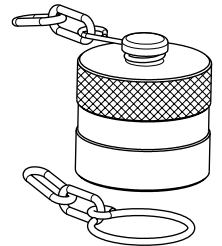

Body Size/Description	Protective Cap		Material/Color
	Plug for Female	Cap for Male	
1/4" IV14HP	815605004	815605005	Carbon steel/Chrome 3
3/8" IV38HP	815605002	815605003	Carbon steel/Chrome 3











VUZ p. 227

Available sizes: From 1/8" to 2"
Operating pressure: Up to 400 bar
Flow rate: Up to 1000 l/min
Material / Treatment:
Carbon steel / Cr3





TECHNICAL FEATURES AND OPTIONS

	Available sizes from 1/8" to 2"		Material High strength carbon steel		Available threads BSP - NPT - SAE
	Standard cracking pressure 0,35 - 4,5 bar		Flow rate Up to 1000 l/min		Sealing description Metal to metal seal
	Operating pressure Up to 400 bar				

BENEFITS

- Optimal wearing resistance of the hardened sealing piston.
- Compact slim design.
- Different cracking pressure available upon request
- Simple to use.

HOW TO USE

- Install the "VUZ" by matching the flow direction with the arrow stamped on the valve.
- To ensure a good efficiency of the system, it is important to select correctly the valve based on flow performances, pressure drop and application.

See the pressure drop graph.

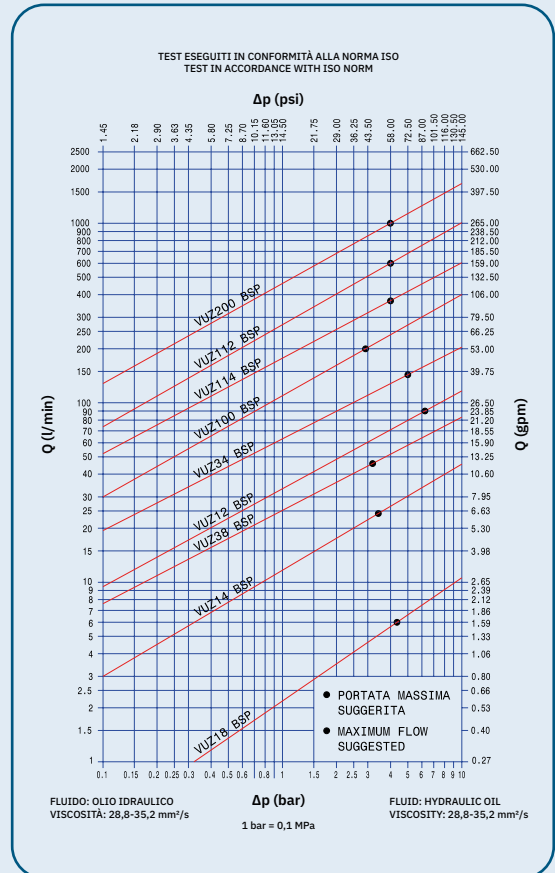

The values of pressure drop are referred to check valve totally opened. If the pressure in the circuit is not sufficient to open totally the valve, the value of pressure drop change.

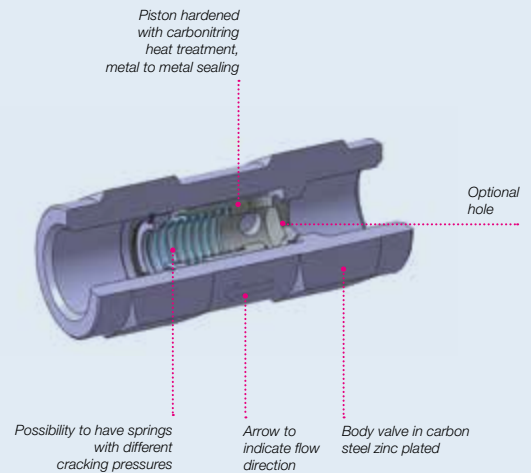

MAIN APPLICATIONS



PERFORMANCES

Size	Series/Size	Max. suggested flow		Max. operating pressure		Burst pressure	
		l/min	gpm	MPa	psi	MPa	psi
1/8	VUZ18	6	1,59	40	5800	160	23200
1/4	VUZ14	24	6,36	35	5075	140	20300
3/8	VUZ38	46	12,19	35	5075	140	20300
1/2	VUZ12	90	23,85	30	4350	120	17400
3/4	VUZ34	148	39,22	30	4350	120	17400
1	VUZ100	200	53,00	30	4350	120	17400
1-1/4	VUZ114	378	100,17	25	3625	100	14500
1-1/2	VUZ112	600	159,00	25	3625	100	14500
2	VUZ200	1000	265,00	15	2175	45	6525

Temperature range:

from -20 °C to +120 °C (from -4 °F to +248 °F).

Please read carefully Instructions and warnings for proper selection of the products.

Different possible configurations:

The VUZ series is also available (in addition to CR3 treatment) with phosphating surface treatment that help the adhesion of paint.

It can be recognized by the burnished black color.

For further information please contact Stucchi Technical support.



WARNING

A defect, a wrong choice or an improper use of products, can cause injury to persons, animals and objects.

Make sure that the medium used is compatible with the material as indicate.

In case of doubt please contact Stucchi Technical Support.

The interchangeability is mentioned under the assumption that the manufacturer of the considered products has not changed any dimension.

It is mandatory to carefully read and closely follow the instructions before selecting or using any Stucchi products.

Always refer to the version uploaded in the Instructions and warning section of stucchigroup.com website for the latest release.

For specific, product-related, instructions, please contact Stucchi technical service.



Reference table for different configuration

BSP THREAD				NPT THREAD				SAE THREAD			
BODY SIZE	CRACKING PRESSURES	DESCRIPTIVE CODE	ITEM CODE	BODY SIZE	CRACKING PRESSURES	DESCRIPTIVE CODE	ITEM CODE	BODY SIZE	CRACKING PRESSURES	DESCRIPTIVE CODE	ITEM CODE
1/8"	5 PSI	VUZ18 BSP 5 PSI	810500100	1/8"	5 PSI	VUZ18 NPT 5 PSI	810501100	1/4"	5 PSI	VUZ14 SAE 5 PSI	810504100
1/4"	5 PSI	VUZ14 BSP 5 PSI	810500101	1/4"	5 PSI	VUZ14 NPT 5 PSI	810501101	3/8"	5 PSI	VUZ38 SAE 5 PSI	810504101
3/8"	5 PSI	VUZ38 BSP 5 PSI	810500102	3/8"	5 PSI	VUZ38 NPT 5 PSI	810501102	1/2"	5 PSI	VUZ12 SAE 5 PSI	810504102
1/2"	5 PSI	VUZ12 BSP 5 PSI	810500103	1/2"	5 PSI	VUZ12 NPT 5 PSI	810501103	3/4"	5 PSI	VUZ34 SAE 5 PSI	810504103
3/4"	5 PSI	VUZ34 BSP 5 PSI	810500104	3/4"	5 PSI	VUZ34 NPT 5 PSI	810501104	1"	5 PSI	VUZ100 SAE 5 PSI	810504104
1"	5 PSI	VUZ100 BSP 5 PSI	810500105	1"	5 PSI	VUZ100 NPT 5 PSI	810501105	1 1/4"	5 PSI	VUZ114 SAE 5 PSI	810504105
1 1/4"	5 PSI	VUZ114 BSP 5 PSI	810500106	1 1/4"	5 PSI	VUZ114 NPT 5 PSI	810501106	1 1/2"	5 PSI	VUZ112 SAE 5 PSI	810504106
1 1/2"	5 PSI	VUZ112 BSP 5 PSI	810500107	1 1/2"	5 PSI	VUZ112 NPT 5 PSI	810501107	2"	5 PSI	VUZ200 SAE 5 PSI	810504107
2"	5 PSI	VUZ200 BSP 5 PSI	810500108	2"	5 PSI	VUZ200 NPT 5 PSI	810501108	3/4"	30 PSI	VUZ34 SAE 30 PSI	810504300
3/8"	5 PSI	VUZ38F1.5 BSP 5 PSI	810500109	1/4"	65 PSI	VUZ14 NPT 65 PSI	810501401	1"	65 PSI	VUZ100 SAE 65 PSI	810504400
3/8"	5 PSI	VUZ38F2 BSP 5 PSI	810500110	3/8"	65 PSI	VUZ38 NPT 65 PSI	810501402	3/8"	65 PSI	VUZ38 SAE 65 PSI	810504401
3/8"	5 PSI	VUZ38F1 BSP 5 PSI	810500111	1/2"	65 PSI	VUZ12 NPT 65 PSI	810501403	1/2"	65 PSI	VUZ12 SAE 65 PSI	810504402
1/4"	14 PSI	VUZ14 BSP 14 PSI	810500200	3/4"	65 PSI	VUZ34 NPT 65 PSI	810501404	3/4"	65 PSI	VUZ34 SAE 65 PSI	810504403
3/8"	14 PSI	VUZ38 BSP 14 PSI	810500201	1"	65 PSI	VUZ100 NPT 65 PSI	810501405	1"	65 PSI	VUZ14 SAE 65 PSI	810504404
1/2"	14 PSI	VUZ12 BSP 14 PSI	810500202	1 1/4"	65 PSI	VUZ114 NPT 65 PSI	810501406	1 1/4"	65 PSI	VUZ114 SAE 65 PSI	810504405
3/4"	14 PSI	VUZ34 BSP 14 PSI	810500203 *	1 1/2"	65 PSI	VUZ112 NPT 65 PSI	810501407	1 1/2"	65 PSI	VUZ112 SAE 65 PSI	810504406
1"	14 PSI	VUZ100 BSP 14 PSI	810500204 *	2"	65 PSI	VUZ200 NPT 65 PSI	810501408	2	65 PSI	VUZ200 SAE 65 PSI	810504407 *
3/4"	30 PSI	VUZ34 BSP 30 PSI	810500300								
3/4"	35 PSI	VUZ34 BSP 35 PSI	810500301								
3/8"	21 PSI	VUZ38 BSP 21 PSI	810500302 *								
1/2"	21 PSI	VUZ12 BSP 21 PSI	810500303 *								
3/4"	21 PSI	VUZ34 BSP 21 PSI	810500304 *								
1/8"	65 PSI	VUZ18 BSP 65 PSI	810500400								
1/4"	65 PSI	VUZ14 BSP 65 PSI	810500401								
3/8"	65 PSI	VUZ38 BSP 65 PSI	810500402								
1/2"	65 PSI	VUZ12 BSP 65 PSI	810500403								
3/4"	65 PSI	VUZ34 BSP 65 PSI	810500404								
1"	65 PSI	VUZ100 BSP 65 PSI	810500405								
1 1/4"	65 PSI	VUZ114 BSP 65 PSI	810500406								
1 1/2"	65 PSI	VUZ112 BSP 65 PSI	810500407								
2"	65 PSI	VUZ200 BSP 65 PSI	810500408								
1 1/2"	73 PSI	VUZ112 BSP 73 PSI	810500500 *								
1/2"	115 PSI	VUZ12 BSP 115 PSI	810500602 *								
3/4"	115 PSI	VUZ34 BSP 115 PSI	810500603								
3/4"	145 PSI	VUZ34 BSP 145 PSI	810500600								
1"	145 PSI	VUZ100 BSP 145 PSI	810500601								

* Available upon request.

PRODUCT DEFINITION

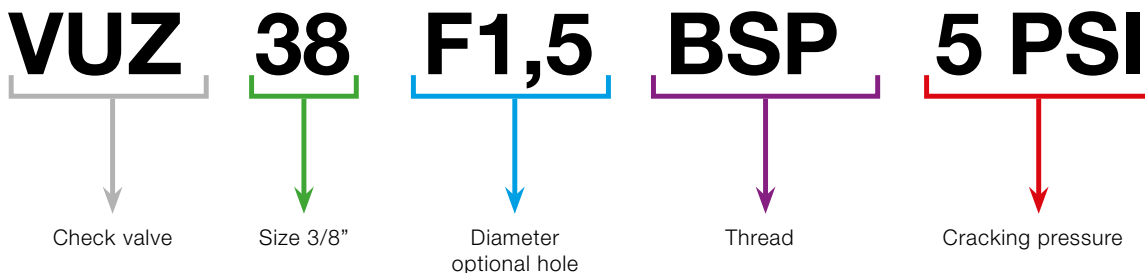

CHECK VALVE

OVERALL DIMENSIONS

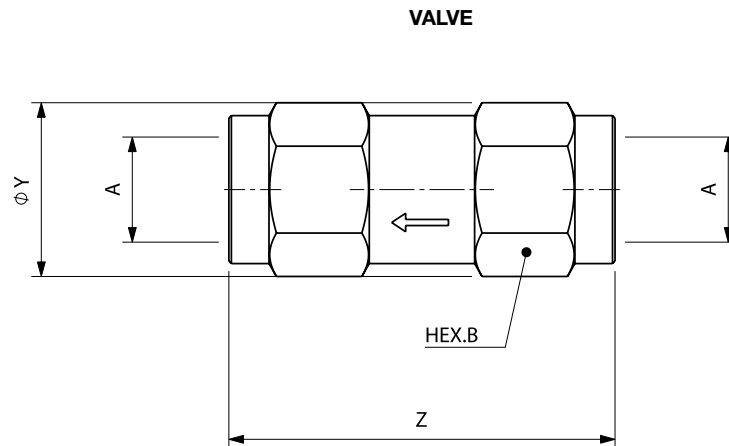

Port description: FEMALE THREAD BSPP (ISO 1179-1)

Descriptive Code	Item Code	PORT (A)	Overall Length		Hex		Diameter		Weight				
			mm	inch	mm	inch	mm	inch	Kg	Lbs			
VUZ18 BSP	see reference table	1/8"	Z	44,0	1,73	B	14,0	0,55	Y	16,2	0,64	0,04	0,08
VUZ14 BSP	see reference table	1/4"	Z	60,0	2,36	B	19,0	0,75	Y	21,9	0,86	0,09	0,20
VUZ38 BSP	see reference table	3/8"	Z	70,0	2,76	B	24,0	0,94	Y	27,7	1,09	0,18	0,39
VUZ12 BSP	see reference table	1/2"	Z	77,0	3,03	B	30,0	1,18	Y	34,6	1,36	0,30	0,66
VUZ34 BSP	see reference table	3/4"	Z	90,0	3,54	B	36,0	1,42	Y	41,6	1,64	0,49	1,08
VUZ100 BSP	see reference table	1"	Z	106,0	4,17	B	45,0	1,77	Y	52,0	2,05	0,87	1,92
VUZ114 BSP	see reference table	1-1/4"	Z	125,0	4,92	B	55,0	2,17	Y	63,5	2,50	1,49	3,28
VUZ112 BSP	see reference table	1-1/2"	Z	140,0	5,51	B	65,0	2,56	Y	75,1	2,96	2,43	5,35
VUZ200 BSP	see reference table	2"	Z	160,0	6,30	B	75,0	2,95	Y	86,6	3,41	3,13	6,90

Port description: FEMALE NPT THREAD (ANSI B.1.20.1)

Descriptive Code	Item Code	PORT (A)	Overall Length		Wrench Flat		Diameter		Weight				
			mm	inch	mm	inch	mm	inch	Kg	Lbs			
VUZ18 NPT	see reference table	1/8"	Z	44,0	1,73	B	14,0	0,55	Y	16,2	0,64	0,04	0,08
VUZ14 NPT	see reference table	1/4"	Z	60,0	2,36	B	19,0	0,75	Y	21,9	0,86	0,09	0,20
VUZ38 NPT	see reference table	3/8"	Z	70,0	2,76	B	24,0	0,94	Y	27,7	1,09	0,18	0,39
VUZ12 NPT	see reference table	1/2"	Z	77,0	3,03	B	30,0	1,18	Y	34,6	1,36	0,30	0,66
VUZ34 NPT	see reference table	3/4"	Z	90,0	3,54	B	36,0	1,42	Y	41,6	1,64	0,49	1,08
VUZ100 NPT	see reference table	1"	Z	106,0	4,17	B	45,0	1,77	Y	52,0	2,05	0,87	1,92
VUZ114 NPT	see reference table	1-1/4"	Z	125,0	4,92	B	55,0	2,17	Y	63,5	2,50	1,49	3,28
VUZ112 NPT	see reference table	1-1/2"	Z	140,0	5,51	B	65,0	2,56	Y	75,1	2,96	2,43	5,35
VUZ200 NPT	see reference table	2"	Z	160,0	6,30	B	75,0	2,95	Y	86,6	3,41	3,13	6,90

Port description: FEMALE SAE THREAD (ISO 11926-1 & SAE J1926-1)

Descriptive Code	Item Code	PORT (A)	Overall Length		Wrench Flat		Diameter		Weight				
			mm	inch	mm	inch	mm	inch	Kg	Lbs			
VUZ14 SAE	see reference table	7/16-20UNF	Z	60,0	2,36	B	19,0	0,75	Y	21,9	0,86	0,10	0,22
VUZ38 SAE	see reference table	9/16-18UNF	Z	70,0	2,76	B	24,0	0,94	Y	27,7	1,09	0,19	0,42
VUZ12 SAE	see reference table	3/4-16UNF	Z	77,0	3,03	B	30,0	1,18	Y	34,6	1,36	0,32	0,69
VUZ34 SAE	see reference table	1-1/16-12UN	Z	94,0	3,70	B	36,0	1,42	Y	41,6	1,64	0,49	1,08
VUZ100 SAE	see reference table	1-5/16-12UN	Z	106,0	4,17	B	45,0	1,77	Y	52,0	2,05	0,87	1,92
VUZ114 SAE	see reference table	1-5/8-12UN	Z	125,0	4,92	B	55,0	2,17	Y	63,5	2,50	1,49	3,28
VUZ112 SAE	see reference table	1-7/8-12UN	Z	140,0	5,51	B	65,0	2,56	Y	75,1	2,96	2,41	5,31
VUZ200 SAE	see reference table	2-1/2-12UN	Z	160,0	6,30	B	75,0	2,95	Y	86,6	3,41	3,00	6,60

VU Series

VUZ series is also available with phosphate conversion coating to help painting adhesion; this series is called VU.

VUZ products differs from the standard VU for their blue-black color.

For complete technical information see stucchigroup.com or contact your Stucchi dealer.







ACR-ACB [p. 235](#)

Valving style: Poppet
Interchange: SAE J639
Sealing description: HNBR
Available sizes: 1/4"
Operating pressure: Up to 41 bar
Material / Treatment: Aluminium, Brass



MP
17.5

STOP

START







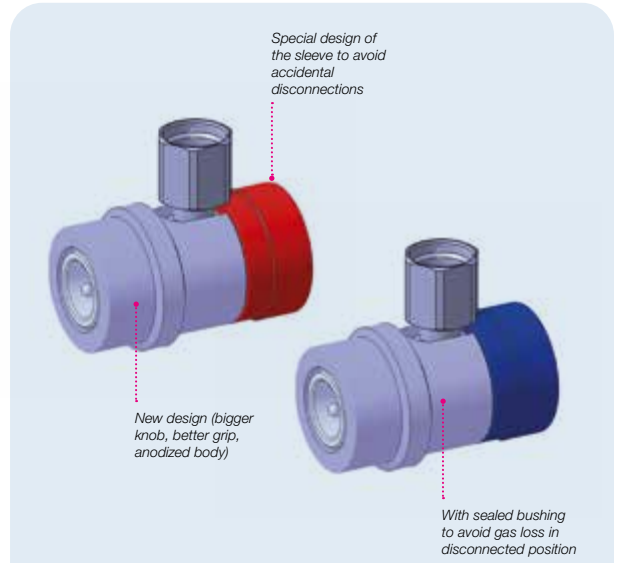





ACR-ACB SERIES

INTERCHANGE > SAE J639



TECHNICAL FEATURES AND OPTIONS

 Interchange SAE J639	 Sealing description HNBR	 Connection system Push - screw
 Available sizes 1/4"	 Material Aluminium, Brass	 Available threads SAE - METRIC
 Operating pressure Up to 41 bar	 Locking mechanism Locking ball + screw to connect	 Temperature (°C) -30° / +130°
 Valving style Poppet		

BENEFITS

- New design (bigger knob, better grip, anodized body)
- Compact size
- High quality
- The new range of Stucchi meet all the requirements of the market: R134A, HFO1234YF, upon request conforming VDA
- With sealed bushing to avoid gas spillage in disconnected position
- Special design of the sleeve to avoid accidental disconnections

HOW TO USE

- Before connection, clean the mating surface of the couplings to avoid dirt inclusion in the circuit.
- To connect turn the knob anticlockwise, then pull back the sleeve of the female coupling, align the female with the male coupling and push one into the other until both halves are fully connected and release the sleeve.
- Refill the cooling system used in A/C system of the car by opening the internal valve turning the knob clockwise.
- To disconnect turn the knob anticlockwise (closing the internal valve), pull back the sleeve of the female coupling and pull out the mating half.

MAIN APPLICATIONS

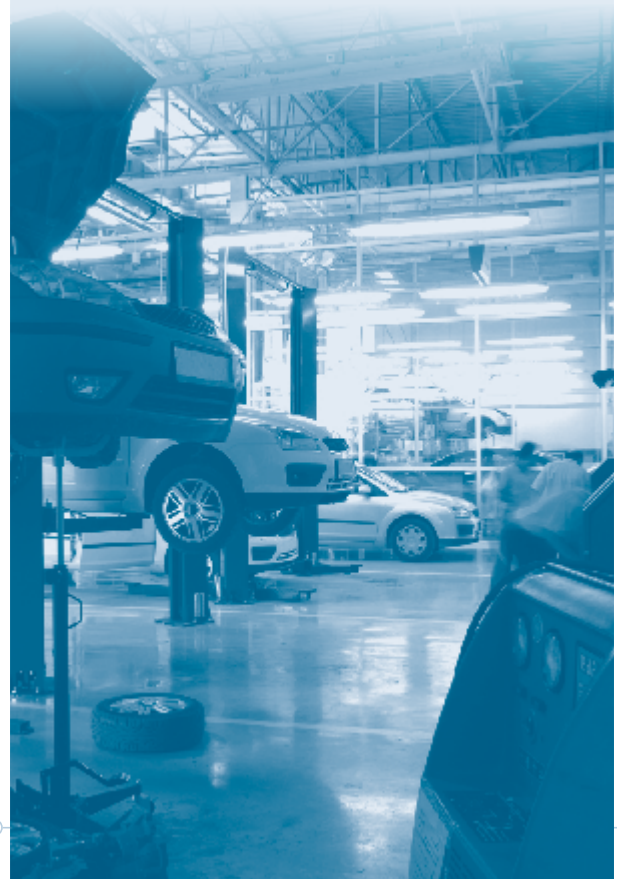

VEHICLE A/C

PERFORMANCES

Size	Series/Size	Max. operating pressure		Burst pressure	
		MPa	psi	MPa	psi
1/4	F ACR/ACB	4.14	600	8,28	1200

- ACR = HIGH PRESSURE version (red color)
- ACB = LOW PRESSURE version (blue color)

- Standard seal in HNBR

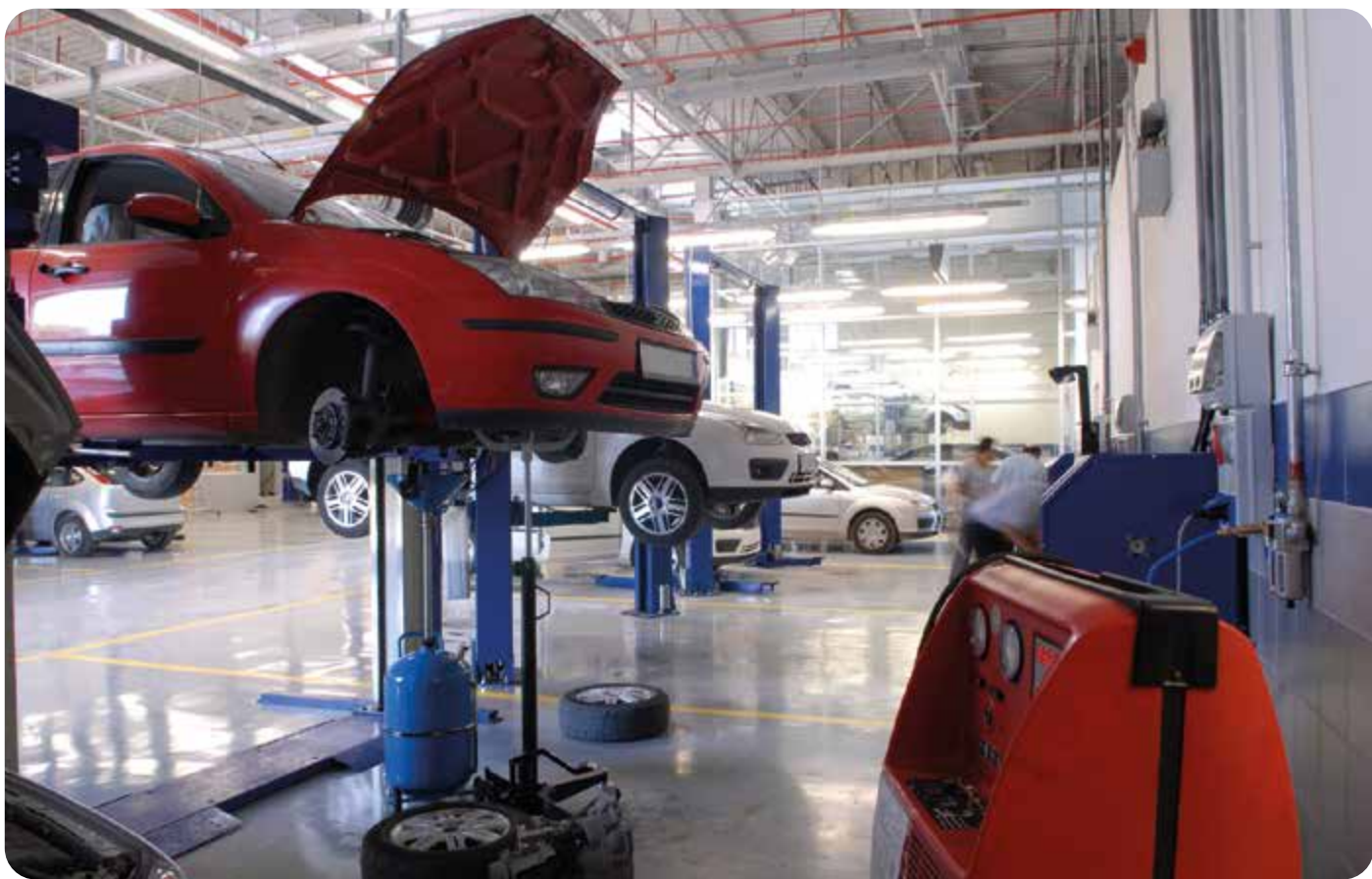

WARNING

A defect, a wrong choice or an improper use of products, can cause injury to persons, animals and objects. Make sure that the medium used is compatible with seal and material as indicated for each series. In case of doubt please contact Stucchi Technical Support. The interchangeability is mentioned under the assumption that the manufacturer of the considered products has not changed any dimension. **It is mandatory to carefully read and closely follow the instructions before selecting or using any Stucchi products.** Always refer to the version uploaded in the Instructions and warning section of stucchigroup.com website for the latest release. For specific, product-related, instructions, please contact Stucchi technical service.

OVERALL DIMENSIONS

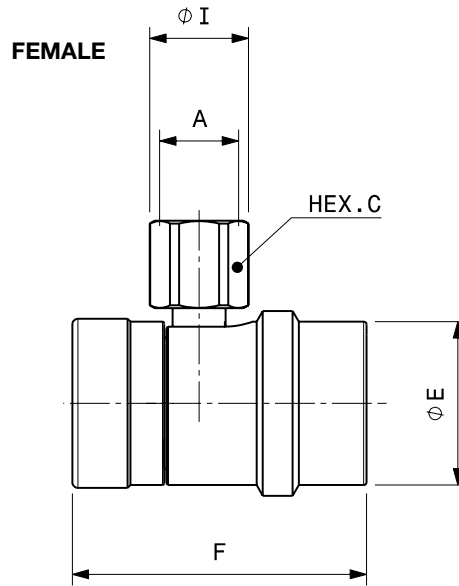

Port description: SAE J2197

Model for refrigerant R134A - port M14X1,5

Descriptive Code	Item Code	PORT (A)	Overall Length		Wrench Flat		Diameter		Diameter		Weight	
			mm	inch	mm	inch	mm	inch	mm	inch	Kg	Lbs
F ACR M14X1.5 90 J639 R134A	Female Red 800262360	A M14X1.5	F 52,2	2,06	C 16,0	0,63	E 29,0	1,14	I 17,5	0,69	0,16	0,35
F ACB M14X1.5 90 J639 R134A	Female Blue 800262362											

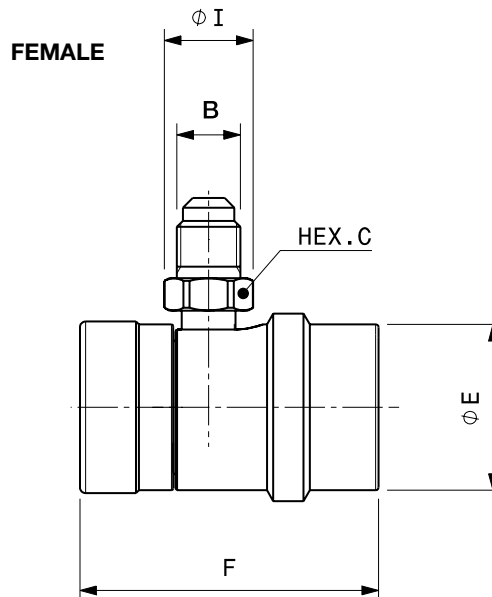

Port description: SAE J2197

Model for refrigerant R134A - port 1/4 SAE45

Descriptive Code	Item Code	PORT (A)	Overall Length		Wrench Flat		Diameter		Diameter		Weight	
			mm	inch	mm	inch	mm	inch	mm	inch	Kg	Lbs
F ACR 1/4 SAE45 90 J639 R134A	Female Red 800255324	B 1/4 SAE45	F 52,2	2,06	C 14,0	0,55	E 29,0	1,14	I 15,5	0,61	0,16	0,35
F ACB 1/4 SAE45 90 J639 R134A	Female Blue 800255326											

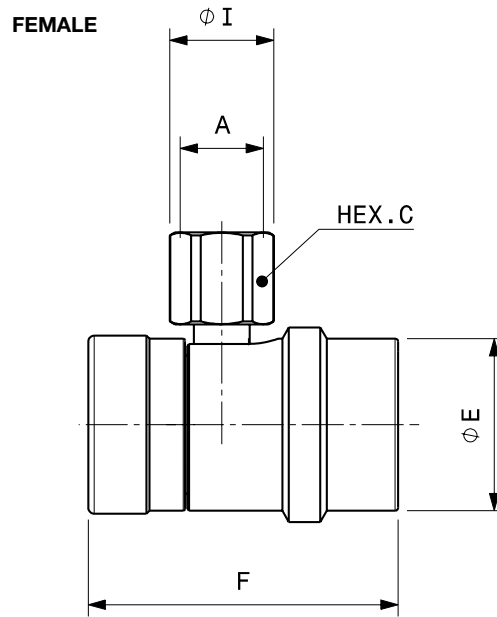

Port description: SAE J2888

Model for refrigerant HF01234YF, upon request conforming VDA

Descriptive Code	Item Code	PORT (A)	Overall Length		Hex		Diameter		Diameter		Weight				
			mm	inch	mm	inch	mm	inch	mm	inch	Kg	Lbs			
F ACR M12 VDA R1234YF	Female Red 800262368	M12 x 1,5	60,8	2,39	C	16,0	0,63	E	29,0	1,14	I	17,5	0,69	0,19	0,42
F ACB M12 VDA R1234YF	Female Blue 800262370	M12 x 1,5	59,8	2,35	C	16,0	0,63	E	29,0	1,14	I	17,5	0,69	0,19	0,42

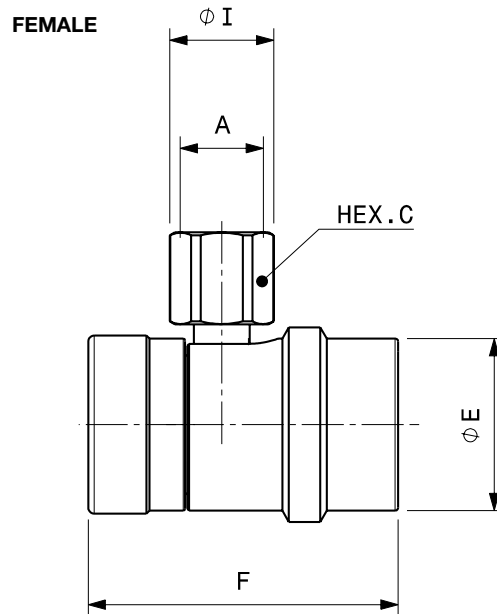

Port description: SAE J2888

Model for refrigerant HF01234YF - NOT CONFORMING VDA

Descriptive Code	Item Code	PORT (A)	Overall Length		Hex		Diameter		Diameter		Weight				
			mm	inch	mm	inch	mm	inch	mm	inch	Kg	Lbs			
F ACR M12 90 J639 R1234YF	Female Red 800262364	M12 x 1,5	55,4	2,18	C	16,0	0,63	E	29,0	1,14	I	17,5	0,69	0,19	0,42
F ACB M12 90 J639 R1234YF	Female Blue 800262366	M12 x 1,5	53,9	2,12	C	16,0	0,63	E	29,0	1,14	I	17,5	0,69	0,17	0,37

Multicouplings



Stucchi®

The multicoupling plate is an innovative and modular solution for any application requiring connection and disconnection of several hydraulic, electrical and pneumatic lines. All the lines are simultaneously connected and disconnected by a safe, simple and quick movement requiring low effort even under residual pressure.

The multicouplings are equipped with flat face couplings that are designed to reduce contamination entering into a circuit, eliminate spillage, and reduce air inclusion during connection and disconnection of the couplings.

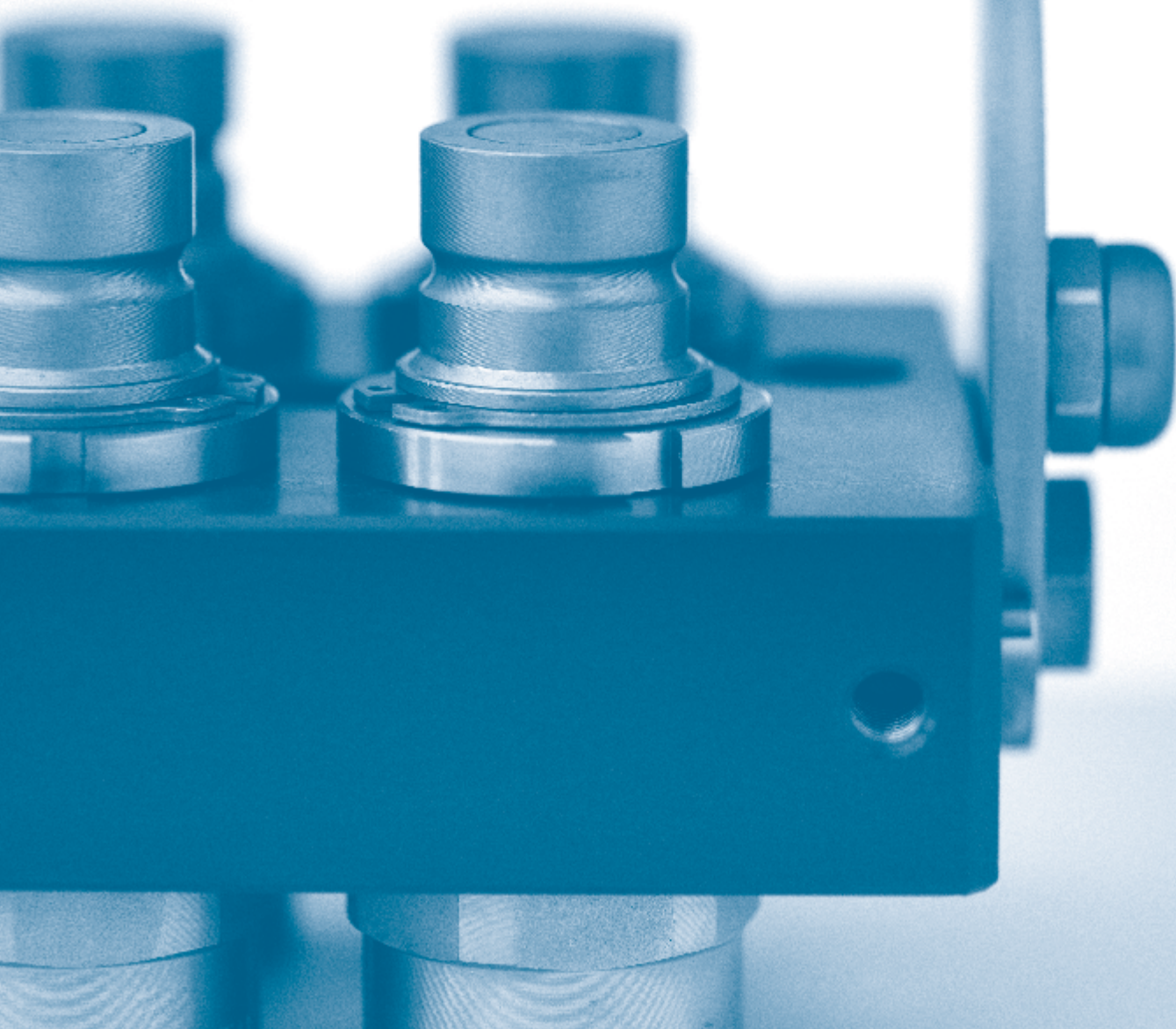

Stucchi offers a flexible and wide range of configurations to satisfy the diverse applications

DP&GR series for hydraulic oil application (up to 10 lines).

Easy
CUP



Easy
CUP



DP

Valving style: Flat face
Interchange: Stucchi profile
Sealing description: Nitrile NBR
Available sizes: From 3/8" to 1"
Flow rate: Up to 378 l/min
Material:
Carbon steel, Aluminium / Cr3
Connection under pressure: Allowed

GR

Valving style: Flat face
Interchange: Stucchi profile
Sealing description: Nitrile NBR
Available sizes: From 3/8" to 1"
Flow rate: Up to 378 l/min
Material: Carbon steel, Brass / Cr3
Connection under pressure: Allowed

GRE Series for industrial low pressure application (up to 18 lines).



GRE

Valving style: Flat face
Interchange: Stucchi profile
Sealing description: Nitrile NBR
Available sizes: From 3/8" to 1/2"
Operating pressure: Up to 10 bar
Flow rate: Up to 90 l/min
Material: Aluminium

For more
information please
contact Stucchi
Technical Support
or visit:
stucchigroup.com



The incorrect use of products can cause malfunctioning and safety risks.

Therefore, before using Stucchi products, we strongly recommend reading and following the “general instructions for selection and use of the products” and the “instructions of use” of the specified product intending to use (to be asked to the Stucchi technical service).

WARNING

A defect, a wrong choice or an improper use of products, can cause injury to persons, animals and objects.

Connection under pressure are under residual pressure.

Never connect or disconnect with dynamic pressure (e.g. pump on).

Make sure that the medium used is compatible with seal and material as indicated for each series.

The interchangeability is mentioned under the assumption that the manufacturer of the considered products has not changed any dimension.

It is mandatory to carefully read and closely follow the instructions before selecting or using any Stucchi products.

Always refer to the version uploaded in the Instructions and warnings section of stucchigroup.com website for the latest release.

In case of doubt or for specific product-related instructions, please contact Stucchi technical service.

1.0 GENERAL INSTRUCTIONS

1.1 Context

These safety instructions form a supplement and shall be used as one document together with the technical documentation related to the specified product to be installed.

1.2 Safeguarding

It is recommended that all systems and equipment be protected so that safety of people, animals and objects will be guaranteed in case of defect of the product.

1.3 Distribution of the instruction

A copy of these instructions has to be supplied to every person responsible for the selection and/or usage of the products.

1.4 Responsibility of the user

Due to the most various range of operating use and conditions of the products, Stucchi does not guarantee that every product can be used for every application. These safety instructions don't analyse all technical parameters that have to be considered by selecting the products.

The end user, through their own analyses and tests, is responsible for the following:

- Final selection of the product
- Ascertainment that the requirements of the end user are satisfied and that the predicted use does not present a safety risk.
- Supply of all warnings regarding the safety of the equipment on which Stucchi products will be used.
- Correct disposal of the product at the end of its life, see paragraph 'disposal instructions'.

2.0 INSTRUCTIONS FOR SELECTION OF THE PRODUCT

2.1 Application fields

Check that the product is suitable for the specific application. In case of doubt, contact the Stucchi Technical Support.

2.2 Type of product

Select the type of product most suitable for the working environment. Flat face couplings: suitable for working environments where it is necessary to reduce to minimum the fluid loss during disconnection and to avoid dirt inclusion during connection. Screw couplings: they are suitable for high working pressure and frequent impulses; they are connectable with high residual pressure. Poppet valve couplings: widely used in the agricultural field.

2.3 Materials and treatments

Make sure that the materials and treatments of the product conform to the exposed working environment.

2.4 Dimensions

Choose the product with dimensions and flow suited to the circuit in order to avoid over stress damaging the product.

2.5 Flow inversion

For application with flow inversion during operation, use only products designed for that scope. Flow inversion during operation generates turbulences inside the product that can cause damage on the components.

2.6 Thread

Choose the product with thread suitable for the application. For high pressure conditions, over 50 MPa, products with taper thread NPT are recommended.

2.7 Type of medium

Verify that the seals of the product are compatible with the medium used in case of doubts please contact Stucchi Technical Support. Make sure that other not compatible fluids do not come in contact with the seals in case of maintenance. Do not use the products with inflammable, explosive or dangerous fluids without approval of Stucchi.

2.8 Medium temperature

Verify that the working temperature is within the functional limits of the coupling and its seals.

The couplings must not be connected and disconnected with a temperature higher than 80 degrees Celsius.

In case of connection-disconnection with temperature higher than 30 Celsius degrees, the operator must be protected using gloves and/or other devices to prevent any leakage or splashing causing injury to himself, persons, animals and objects.

2.9 Environment temperature

With extreme temperature conditions, the mechanical resistance of the products changes. The use and handling of couplings in case of ice can be difficult due to ice inclusion in the blocking mechanisms.

Use protective gloves in applications with hot and cold operating temperature.

2.10 Pressure

Verify always if the maximum working pressure of the product is the same or higher than the pressure peaks of the application.

Do not make confusion between the burst pressure and the maximum working pressure, so do not use the value of the burst pressure for your selection.

Check that the number of impulse cycles which the product has been tested is compatible with the impulse number of the application.

2.11 Residual pressure

For connection and disconnection with residual pressure use only couplings that are developed for this scope.

The term 'internal residual pressure' means: the static pressure retained in the system, which has not be generated by a working pump or other accessories in movement.

The structure of the machine or plant in which these products are placed, must be suitable to limit accidental splashing and fluid losses caused by wrong usage or malfunctioning of the product, in order to avoid direct and indirect damage on persons, animals or objects. The temperature of the fluid must not exceed the limits mentioned in point 2.8

2.12 Connection frequency

It is important to know the connection frequency with which the coupling is used, while this has significant influence on the life of both springs and seals.

An under-estimated value can cause unexpected fluid loss.

2.13 Safety device

If used in environments or machines in strict closeness at persons, animals or objects (1 meter), within easy accidental disconnection conditions, it is highly recommended to use ball locked couplings with security system or screw couplings and to make sure that the preventive disconnection mechanism is correctly screwed together.

2.14 Mechanical loads

Side loads, mechanical stresses in general and vibrations reduce significantly the life of the product and are often the cause of sudden damages.

It is recommended to assemble quick release couplings without risks of mechanical damage and over-loading caused by stress generated in flexible or rigid hoses and to assemble quick release couplings on hoses with proper dimensions referred to the nominal passage of the quick release coupling.

2.15 Rotation

In case of applications with rotation use only products developed for this scope. In case of rotation between male and female part it is necessary to inform in advance Stucchi Technical Support or to provide the connection with swivel joints suitable for this scope.

2.16 Special applications

You should be advised to take particular attention to special applications (such as vacuum use, high temperature, etc...).

Please consult Stucchi Technical Support who is able to give instructions concerning the use of Stucchi products.

Do not use Stucchi products in nuclear, aircraft or military field; do not use Stucchi products in explosive environment or with inflammable, explosive or dangerous fluid. In this cases contact Stucchi Technical Support for assistance.



3.0 INSTRUCTIONS FOR STOCK PRESERVATION

For a correct preservation of the product and in order to avoid damage before even starting to use the product read carefully the following instructions.

3.1 Packaging

The products have to be kept in closed packaging to protect the components, mainly the seals, from dust and ultraviolet rays.

3.2 Environments

The products shall be kept in environments with low percentage of humidity, no condensation, no salt, protected from atmospheric factors, far away from heating devices and magnetic fields. Eliminate equipment that can produce ozone, as this element is extremely destructive for the seals.

3.3 Protection cap

The protection cap assembled on the thread has to be removed at the moment of the product installation only.

3.4 Special packaging

In case of requests for special packaging contact the customer service.

4.0 INSTALLATION INSTRUCTIONS

4.1 Pre Installation inspections

Before installation of the product it is necessary to inspect it visually and to verify if the part number and description of the product refers to the one requested.

4.2 Hose size

The optimal is to use the hoses having the same sizes as the coupling body, can be used the hoses having one size more (step up) than the coupling but not bigger otherwise they can overstress the coupling with risk of failure.

4.3 Hose assembling

In case of single coupling one part (female or male) can be assembled directly on the rigid tube, but the other part shall be assembled on the flexible hose in order to allow an easy connection and absorb better the vibration and mechanical stress. In case of the multicoupling both parts (fixed and mobile) shall be assembled on the flexible hoses to avoid the misalignment of the couplings. Once connected the flexible hose should create a right radius according to the hose manufacturer specifications, in this way the connection/disconnection of the couplings takes place in easy way and aligned position.

4.4 Side load

Don't apply radial/axial loads that create misalignment of the couplings during connection/disconnection and can cause damage on the connection and sealing parts.

4.5 Fitting assembling

Use fittings and sealing systems conform to the thread of the product only. To install and remove the couplings use proper tools and act only on flat spanner surfaces of the coupling. Do not use improper tools (spanner for hoses, bench vice, pincer etc.) while these can cause damage on the coupling with malfunction as result. Use the tightening torque stabilized by the norm to screw the fittings

4.6 Positioning of the coupling

It is suggested to install the couplings in such way that they can easy be connected and disconnected, reducing to the minimum the forces and risks for the operator. It's suggested to install the coupling not exposed in order to protect it from collision with other parts. It is suggested to protect the couplings using shelters and protections (see sector norms) to guarantee the security and to prevent damage.

5.0 INSTRUCTIONS OF USE

5.1 Modality of use

The modality of use changes in accordance to the type of product used.

For every type of product, the modality of use described in the catalogue or the specific usage instructions supplied by Stucchi have to be carefully followed. The system has to be immediately stopped and the product should be replaced whenever one of the following conditions will occur:

- Visible damage, damaged parts of the product, cracks and corrosion.
- Difficulties in connection and disconnection generated by too high force compared to the data mentioned in the catalogue.
- Presence of leakage.
- Malfunctioning of the valve.

In the above mentioned cases please contact Stucchi Technical Support for information.

5.2 Connection / Disconnection

Before connecting, the parts of the couplings involved in the connection have to be cleaned. Connection with dirty parts may cause damage such as unexpected and dangerous leakage on the coupling. Another consequence of dirt is contamination of the system. Do connect and disconnect the coupling only as indicated in the modality of use: do not use other unsuitable tools. A loss of fluid contained in the circuit may occur during the disconnection of the coupling. The approximate spillage values are shown in the catalog. It is recommended to pay maximum attention during the disconnection phase and to activate the necessary precautions to avoid the dispersion of fluids in the environment.

5.3 Mechanical damage

The product shall not be exposed to mechanical damages while they can cause damage and malfunctioning. Do not use tools to open the valves to release residual pressure trapped in the circuit.

5.4 Circuits cleaning

Use the products in clean circuits. Dirt can damage components of the product and cause malfunctioning.

5.5 Protection caps

Use anti-dust caps when coupling is disconnected to avoid dirt and contamination and to protect the surface from accidental damage caused by collisions.

5.6 Use of semi-couplings of other manufacturers.

Do not connect Stucchi half-couplings with other not compatible half-couplings. In case of connection of a Stucchi half-coupling with a half-coupling from another manufacturer, do not exceed the lowest nominal pressure of the two products.

6.0 MAINTENANCE INSTRUCTIONS

The good functional of product is often compromised by a lack of maintenance. To avoid unexpected damage that can cause times of arrest and safety risks it is necessary to apply maintenance periodically.

The period dedicated to the maintenance of the product has to be defined by the user and depends on the type of application and on the working conditions the product is exposed to.

6.1 Ordinary - Preventive maintenance

First, the product should be well cleaned and the area where it is installed as well, then you should check and verify the following steps:

- Absence of breakage or various damage on the products.
- Absence of leakage in general.
- Correctness of tightening torque of the adapters.
- Check the level of circuit contamination.
- The connected parts or the parts in movement should be greased with grease compatible with the seals assembled in the products.
- The replacement of the coupling should be planned in accordance with the requested endurance for the specific application.

6.2 Repair

In case of repair of the products it is recommended to follow Stucchi's specific instructions and use spare parts, tools and documentation supplied by Stucchi only. Please contact Stucchi Technical Support for the above specific information.

7.0 Disposal instructions

Do not litter the product after use. The product must be disposed according to the local law and the requirements of the relevant local authorities. Details about product composition are reported in the catalogs on stucchigroup.com. The user is responsible for the waste characterization and its disposal.

IT IS THE RESPONSIBILITY OF THE USER TO SELECT, INSTALL AND USE THE QUICK RELEASE COUPLING IN THE CORRECT WAY.

The texts, data and illustrations indicated in this catalogue, may be changed by Stucchi S.p.A at any time without notice. For more information please contact the Stucchi Technical Support, in any case we remind for **last updated version always applied at time of installation, see latest written instruction on stucchigroup.com before selecting or using Stucchi products.**



Unit of measure

**Anglo Saxon
Imperial System
(USA)**



Characteristic

**International
Metric System (SI)**

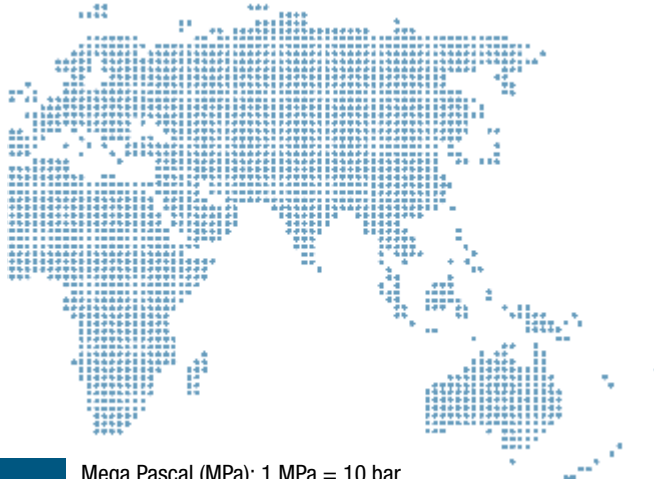

Pound/Square Inch (psi)	PRESSURE	Mega Pascal (MPa); 1 MPa = 10 bar
Gallon per minute (US-gpm)	FLOW IN HYDRAULIC	Liter per minute (l/min)
Pound force (lbf)	FORCE	Newton (N); 1 Newton (N) = 0,1019 Kg/Force
Pound force per Foot (lbf ft)	TORQUE	Newton meter (Nm)
Fahrenheit degree (°F)	TEMPERATURE	Celsius degree (°C)
Inch (Inch) Foot (ft)	LENGHT	Millimeter (mm) Meter (m)
Pound (lb)	WEIGHT	Kilogram (kg)

Temperature

USA > SI

- 1 psi = 0,0069 Mpa
- 1 gpm = 3,78 l/min
- 1 lbf = 4,444 N
- 1 lbf ft = 1,357 Nm
- °F = (°C*1,8)+32
- 1 Inch = 25,4 mm 1 ft = 0,3048 m
- 1 lb = 0,4536 kg

SI > USA

- 1 Mpa = 145 psi
- 1 l/min = 0,265 CPM
- 1 N = 0,225 lbf
- 1 Nm = 0,737 lbf ft
- °C = (°F-32)/1,8
- 1 mm = 0,03937 Inch 1 m = 3,28084 ft
- 1 kg = 2,2046 kg

Conversions

SEAL Temperature range

It is a generic indication of the seal temperature range given by Stucchi seal suppliers after laboratory tests made in standard conditions. It is given for Customer information only (is intended as a guide but not as a warranty). It does not mean all the Stucchi products are homologated for such seal temperature range. Fluid in use, external condition (radiant heating, temperature changes...), internal condition (duration of exposure, state changes of the fluid, thermal expansion...) should be taken into account. Every application has to be analyzed by the Customer prior to do the final choice. Please contact us for further information.

SEAL compatibility

Verify that the seals of the product are compatible with the medium used. Make sure that no other not compatible fluids do not come in contact with the seals in case of maintenance or due to external environment condition. Do not use Stucchi product with flammable, explosive or dangerous fluids. We always recommend to do a customer verification & validation test to approve the products in the specific application prior to do the final choice. Please contact us for further information.

Temperature range Celsius degrees °C	Seal coumpound	Temperature range Fahrenheit degrees °F
-20 > +100	NBR (Nitrile)	-4 > +212
-15 > +180	VITON®	+5 > +356
-40 > +150	EPDM (Ethylene Propylene)	-40 > +302
-25 > +300	KALREZ®	-13 > +572
-30 > +130	HNBR	-22 > +266
-50 > +150	FLUROSILICON	-58 > +302
-50 > +150	SILICON	-58 > +302
-40 > +100	NEOPRENE	-40 > +212
-50 > +180	PTFE (Teflon®)	-58 > +356

Size, different references

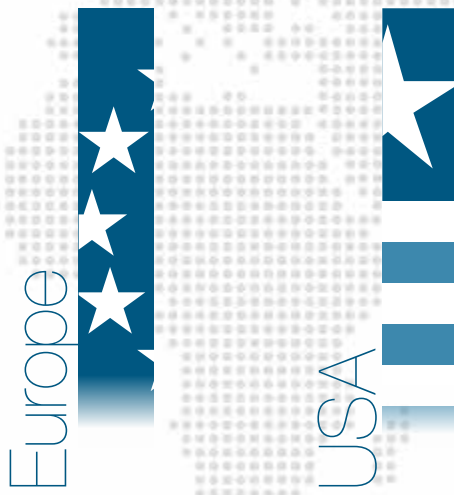
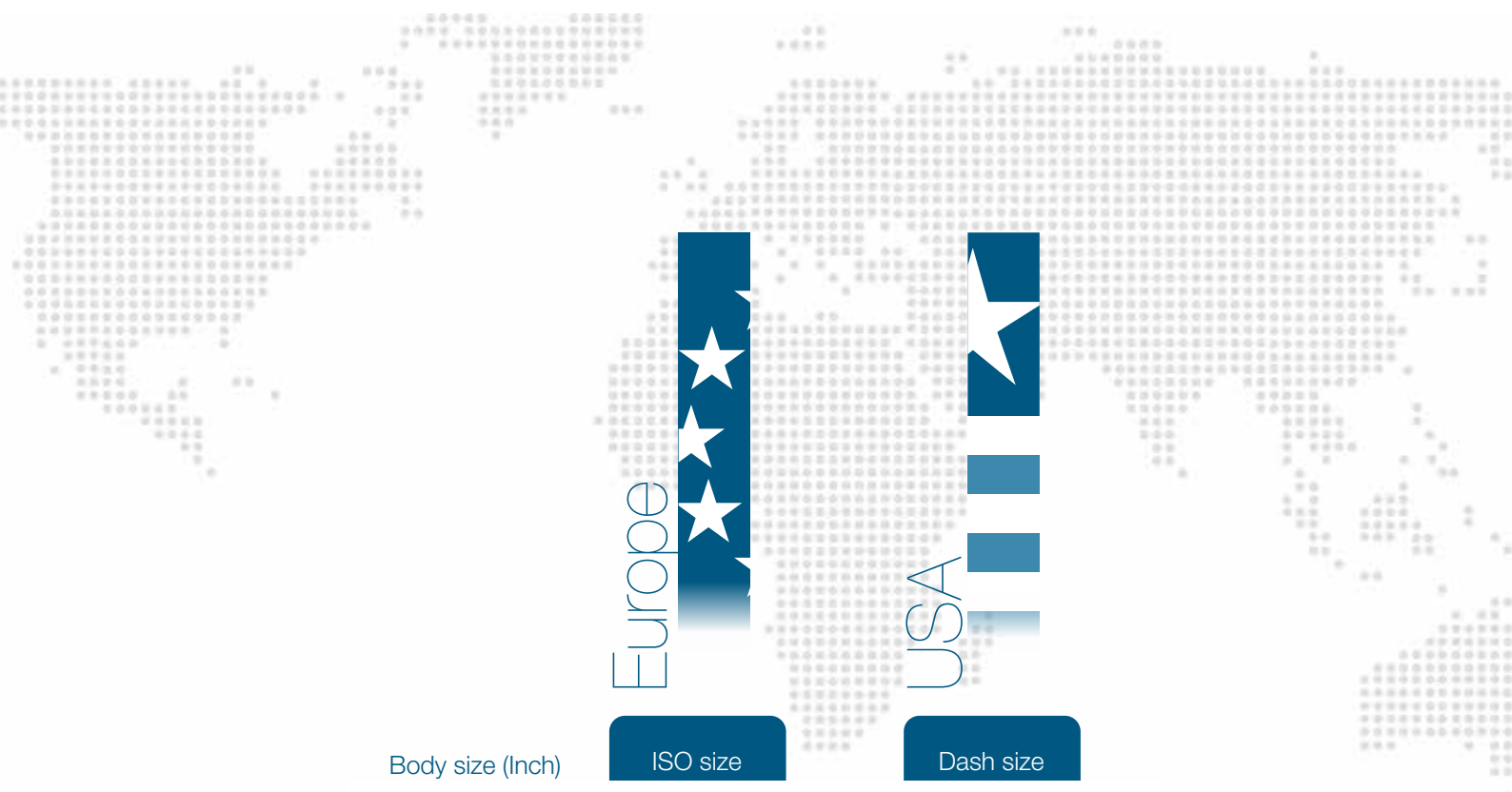

Body size (Inch)	ISO size	Dash size
1/8	(4)	-2
1/4	6.3	-4
3/8	10	-6
1/2	12.5	-8
5/8	16	-10
3/4	19	-12
1	25	-16
1-1/4	31,5	-20
1-1/2	40	-24
2	50	-32



Brinelling

Markings of the locking balls on the metallic parts where they are in contact with high impulse applications.

Burst pressure

Value of pressure at which a coupling loses its ability to retain pressure.

Dis/Connect force

Value of force required to dis/connect the couplings without residual pressure in the system.

Connect torque

Value of torque required to connect the couplings without residual pressure in the system.

Coupled

Male coupling half connected with the female coupling half.

Disconnect torque

Value of torque required to disconnect the couplings without residual pressure in the system.

Interchangeability

Possibility of male coupling half or female coupling half to connect with the other brands of couplings.

ISO Size

Size indicated by ISO standard (the International Organization for Standardization) related to interchangeability of the couplings.

ISO Norm

The norms used as reference for the test method are two: ISO 7241-2 issued in 1986 then canceled and replaced in 2017 by the new ISO 18869.

Mechanical connection

Method or type of connection that creates retention between the male coupling half and female coupling half.

Max. flow suggested

Max. flow suggested by Stucchi

Max. operating pressure

The maximum peak of pressure at which can be used the product.

Max. residual pressure during connection

Max. allowed residual pressure (pressure trapped in the circuit) to connect the coupler.

Max. residual pressure during disconnection

Max. allowed residual pressure (pressure trapped in the circuit) to disconnect the coupler.

Pressure drop

Pressure lost between the inlet and the outlet of the coupling.

Quick coupling

A quick, easy, sure product to repeatedly connect and disconnect almost any fluid line in a system and to turn off the flow immediately upon disconnect.

Rated flow

Typical rated flow relative to the size, in accordance with ISO norm standard.

Size

Nominal size of coupling body.

Spillage

Indicative value of the fluid loss per couple - uncouple cycle without residual pressure. Checked on sample in accordance with ISO norm test method.

Temperature range

See page 244.

Tightening torque

Recommended torque to apply during connection on screw to connect couplings to prevent accidental disconnection.

Valve system

Type of valve used to shut-off medium flow in the male or female coupling half once disconnected.



Stucchi S.p.A.
Headquarter

Via della Lira Italiana, 397
24040 Pagazzano (BG) Italy
stucchigroup.com



Stucchi USA inc.

1105 Windham Parkway,
Romeoville
IL 60446 USA
stucchiusa.com

Stucchi (Shanghai)

Fluid Power Technology Co., Ltd
No. 5, Lane 3500, Xiupu Road
Kangqiao Industrial Park
Pudong New District
201315 Pudong Shanghai, China
stucchichina.com

Stucchi FCP Pty Ltd.

8/7-11 Rodeo Drive
Dandenong South
VIC 3175 Australia

Unit3, 22 Strathwyn Street
Brendale,
QLD 4500 Australia
stucchigroup.com/en-au

Stucchi Engates Hidraulicos Ltda.

Rua Henrique Manasses, 105
Salas 03, 04, BOX 84
18086-610, Bairro Eden
Sorocaba - SP, Brasil
stucchigroup.com/br-pt

